GEOSOFT 2.0

 *User Manual*



CONTENTS

INTRODUCTION	6
MENU SELECTIONS	7
FILE MENU	7
<i>New</i>	7
<i>Open</i>	7
<i>Save</i>	7
<i>Save As</i>	7
<i>Import Geosoft 1 Projects</i>	7
<i>Export</i>	7
<i>Print</i>	7
<i>Exit</i>	7
EDIT MENU	8
<i>Add Cluster</i>	8
<i>Duplicate Cluster</i>	8
<i>Delete Cluster</i>	8
<i>Rename Cluster</i>	8
<i>Edit Cluster Positions</i>	8
EDIT VENUE	9
SPECTRUM (NEW).....	9
<i>Show / Hide Spectrum</i>	9
<i>New Point</i>	10
<i>Edit Point</i>	10
<i>Delete Point</i>	10
OPTIONS MENU	10
<i>Meter / Feet Units</i>	10
<i>Edit air absorption</i>	11
<i>3D Mode / 2D Mode</i>	11
HELP MENU	11
<i>Help</i>	11
<i>Structural Analysis</i>	11
<i>User Manuals</i>	11
<i>About Geosoft</i>	11



ENTERING & EDITING VENUE.....	12
EDIT VENUE PLANES.....	12
<i>Audience</i>	13
<i>Annotation</i>	13
<i>Vertex 1 to 4</i>	13
MENU	13
<i>Edit Venue (3D Mode)</i>	13
<i>Add plane</i>	14
<i>Duplicate plane</i>	14
<i>Delete Plane</i>	14
<i>Invert Plane</i>	14
<i>Set Audience for all</i>	14
<i>Open Venue File</i>	14
<i>Importing Audience planes from Ease 4</i>	14
<i>Save Venue File</i>	14
<i>Edit Venue (2D Mode)</i>	15
PROJECT WINDOW	16
<i>Project</i>	16
<i>Company</i>	16
<i>Author</i>	16
<i>Date</i>	16
<i>Text Window</i>	16
GEO CLUSTER ACOUSTIC WINDOW	17
<i>Cluster Type</i>	17
<i>Speaker Quantity</i>	17
<i>Insert / Remove</i>	17
<i>Move Towards Bumper / Move Away Bumper</i>	17
<i>Rig Angles Tab</i>	18
<i>Step</i>	18
<i>CDD</i>	19
<i>Cluster Position</i>	19
<i>Pressure Plot and Frequency Response display</i>	19
<i>Simulation conditions</i>	20



GEO S8 CLUSTER MECHANICAL WINDOW	21
CONFIGURATION SETTINGS	21
<i>Rigging Mode</i>	21
<i>Wind Beaufort 8</i>	21
<i>Cluster Secured</i>	21
CLUSTER DIMENSIONS AND WEIGHT	22
MECHANICAL FORCES.....	23
ANGLE SEQUENCE.....	23
WORKING LOAD – SAFETY FACTOR – LIFTING FACTOR	24
<i>Percentage of Allowed Working Load</i>	24
<i>Safety Factor for 100% of Allowed Working Load</i>	24
<i>Lifting Factor</i>	24
CAUTION – WARNING MESSAGES	24
<i>Permanently displayed messages</i>	24
<i>Conditional messages</i>	24
<i>Cluster Drawings</i>	25
GEO S12 CLUSTER MECHANICAL WINDOW	26
CONFIGURATION SETTINGS	26
<i>Rigging Mode</i>	26
<i>Rigging point position</i>	26
<i>Rear rigging point</i>	26
<i>Front rigging point</i>	26
<i>Wind Beaufort 8</i>	26
<i>Cluster Secured</i>	26
CLUSTER DIMENSIONS AND WEIGHT	27
MECHANICAL FORCES.....	28
ANGLE SEQUENCE.....	28
WORKING LOAD – SAFETY FACTOR – LIFTING FACTOR	28
CAUTION – WARNING MESSAGES	28
<i>Permanently displayed messages</i>	28
<i>Conditional messages</i>	28
<i>Cluster Drawings</i>	29



GEO D CLUSTER MECHANICAL WINDOW	30
CONFIGURATION SETTINGS	30
<i>Rigging top (case dependent, selectable)</i>	<i>30</i>
<i>Rigging bottom (case dependent, automatic)</i>	<i>30</i>
<i>Chain lever hoist (selectable)</i>	<i>30</i>
<i>Wind Beaufort 8.....</i>	<i>30</i>
<i>Cluster Secured.....</i>	<i>30</i>
CLUSTER DIMENSIONS AND WEIGHT (2 RIGGING POINTS)	31
MECHANICAL FORCES.....	32
CLUSTER DIMENSIONS AND WEIGHT (1 RIGGING POINT).....	33
MECHANICAL FORCES.....	34
ANGLE SEQUENCE.....	35
WORKING LOAD – SAFETY FACTOR – LIFTING FACTOR	35
<i>GeoD cluster - Percentage of Allowed Working Load.....</i>	<i>35</i>
<i>GeoD cluster - Safety Factor for 100% of Allowed Working Load</i>	<i>35</i>
CAUTION – WARNING MESSAGES	36
<i>Permanently displayed messages</i>	<i>36</i>
<i>Conditional messages</i>	<i>36</i>
<i>Cluster Drawings</i>	<i>36</i>
GEO T CLUSTER MECHANICAL WINDOW.....	37
CONFIGURATION SETTINGS	37
<i>Rigging Mode</i>	<i>37</i>
<i>Wind Beaufort 8.....</i>	<i>37</i>
<i>Cluster Secured.....</i>	<i>37</i>
CLUSTER DIMENSIONS AND WEIGHT	38
MECHANICAL FORCES.....	39
ANGLE SEQUENCE.....	40
WORKING LOAD – SAFETY FACTOR – LIFTING FACTOR	40
<i>GeoT cluster - Percentage of Allowed Working Load.....</i>	<i>40</i>
<i>GeoT cluster - Safety Factor for 100% of Allowed Working Load.....</i>	<i>40</i>
<i>CD18 cluster - Percentage of Allowed Working Load.....</i>	<i>40</i>
<i>CD18 cluster - Safety Factor for 100% of Allowed Working Load.....</i>	<i>40</i>
CAUTION – WARNING MESSAGES	41
<i>Permanently displayed messages</i>	<i>41</i>
<i>Conditional messages</i>	<i>41</i>
<i>Cluster Drawings</i>	<i>41</i>



INTRODUCTION

GEOSoft2 software is a R&D simulation tool derived application. It processes measured speaker data with complex mathematical algorithms to assist the user in designing vertical GEO Tangent Arrays that provide even SPL throughout the depth of the audience. Due to the complexity of the interaction of multiple cabinets, it is simply not possible to reliably design curved vertical arrays without using the processing power of a computer to predict the optimum array structure for a given audience geometry. The design logic is far more complex than looking at a section drawing of the venue, measuring the overall angle needed to cover the audience from the cluster location, and dividing by 5degrees to determine the required amount number of S805 cabinets.

GEOSoft2 is an easy to use tool that allows to shape the energy leaving the cluster to fit the audience. It predicts pressure levels radiated from the system to ensure enough cabinets are provided for the application, as well as mechanical constraints for safe flown systems.

In addition, it provides mechanical information for all clusters in agreement with Structural Analysis Reports (available in the Help section): dimensions, weight, gravity center position, forces, moments, working load and safety factor.

Geo S8, Geo D and Geo T Structural Analysis Reports have been validated by German Certification Organization RWTUV systems GmbH.

Geo S12 Structural Analysis Report is currently being examined by German Certification Organization RWTUV systems GmbH.

Please check the NEXO Web Site periodically (www.nexo-sa.com) for upgrades.

Any question or bug report please contact geosoft@nexo.fr

MENU SELECTIONS

File Menu



New

Opens a blank file (GeoS Cluster, no venue information)

Open

Opens previously saved configuration *filename.nexo*

Save

Saves the configuration as previously saved *filename.nexo*

Save As

Saves the configuration as *filename.nexo* (approximate size : 50 KB).

Import Geosoft 1 Projects

Imports Geosoft 1 .MAT file (extends Geosoft 2D lines to 3D 2 meters width planes)

Export

Exports currently displayed window in a JPEG format (approximate size: 100 kB).

Print

Opens Print Dialog Window and Preview

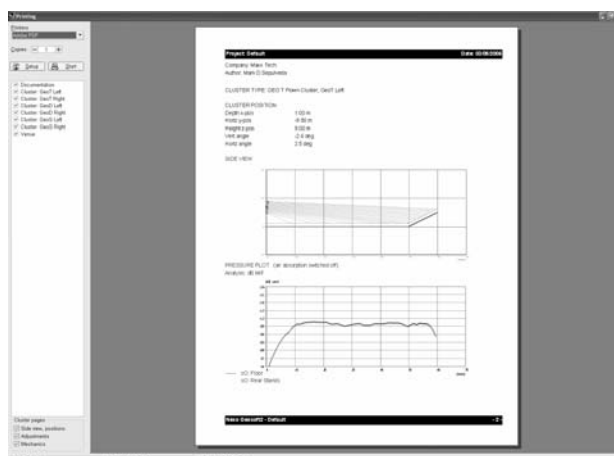

Exit

Ends the Geosoft 2 session.

Edit Menu

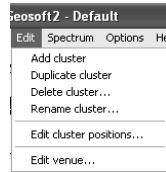

Add Cluster

Adds Cluster (New Cluster Window)

Duplicate Cluster

Opens Offset Position Window, which allows x or y cluster mirroring and offset cluster duplication

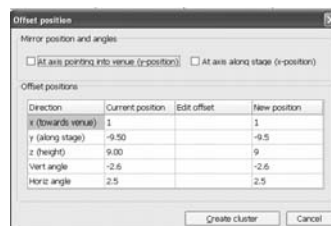

Delete Cluster

Deletes Selected Cluster (Deletes selected Cluster Tab)

Rename Cluster

Renames Cluster

Edit Cluster Positions

Opens the Edit Cluster Window:

Cluster	Depth, x-pos (Meter)	Horiz, y-pos (Meter)	Height, z-pos (Meter)	Horiz angle (degree)	Vert angle (degree)	Show horiz coverage
GeoT Left	1.00	-9.50	9.00	2.5	-2.6	<input type="checkbox"/>
GeoT Right	1	9.5	9	-2.5	-2.6	<input type="checkbox"/>
GeoD Left	20	-9.5	9	1.5	-1	<input type="checkbox"/>
GeoD Right	20	9.5	9	-1.5	-1	<input type="checkbox"/>
GeoS Left	-3.50	-12.00	9.00	-45	-11	<input type="checkbox"/>
GeoS Right	-3.50	12.00	9.00	45	-11	<input type="checkbox"/>

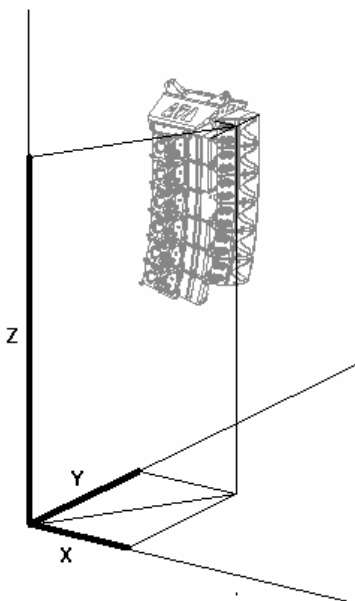

Depth, x-pos

when cluster flown, distance between top of first cabinet and venue geometry reference point 0 along X axis;

when cluster stacked, distance between bottom of first cabinet and venue reference point 0 along X axis;

Horiz, y-pos

when cluster flown, distance between center of first cabinet and venue geometry reference point 0 along Y axis;

when cluster stacked, distance between center of first cabinet and venue reference point 0 along Y axis;

Height, z-pos

when cluster flown, distance between top of first cabinet and venue geometry reference point 0 along Z axis;

when cluster stacked, distance between top of first cabinet and venue reference point 0 along Z axis;

Horizontal angle (Positive CCW looking from top) and **Vertical angle** (Positive going up) are for Cluster Orientation;

Show Horizontal Coverage displays -6dB lines for selected cluster in Venue tab; these line are defined as the intersection between each cabinet nominal -6dB coverage triangle and venue planes.

Edit Venue

Opens the Edit Venue Planes Window:

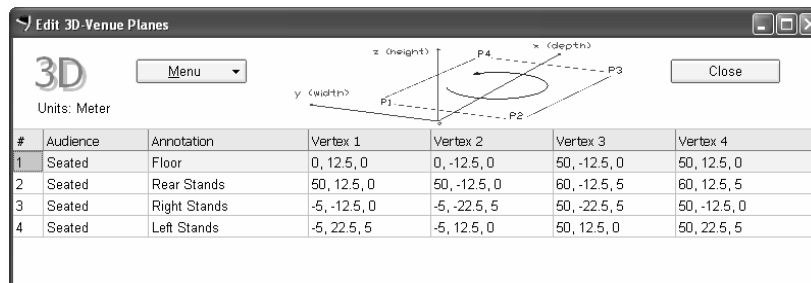

Please refer to Editing Venue section for features description.

Spectrum (new)

Show / Hide Spectrum

Show Spectrum displays Frequency Response Plot next to Pressure Plot.

Hide Spectrum is identical to previous version display

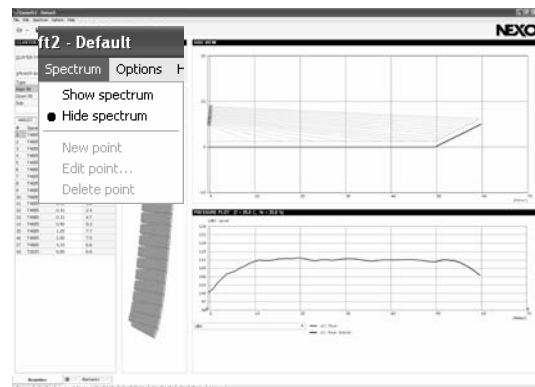
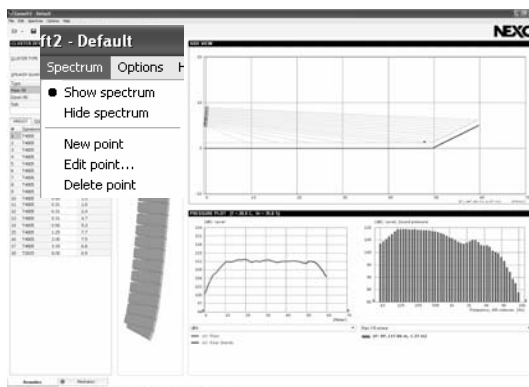



New Point

Opens Spectrum Point Coordinates Input Window

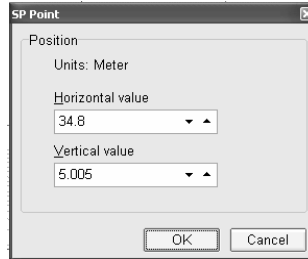

Edit Point

Opens Selected Spectrum Point Coordinates Input Window for editing

Delete Point

Deletes Selected Spectrum Point

Options Menu

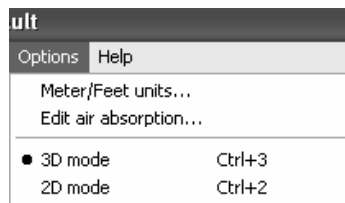

Meter / Feet Units

Opens the Units Window:

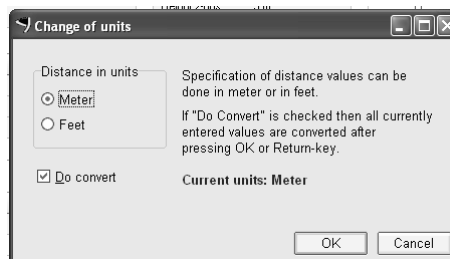

- Do Convert:
 - when selected, switching from Meter to Feet (or vice versa) will not change Venue dimensions
 - when unselected, switching from Meter to Feet (or vice versa) will not change numerical X/Y/Z values and will therefore scale up or down the venue.
- Meter: the project is defined in the metric (m) - kilogram (kg) units system;
- Feet: the project is defined in the feet (ft) - pound (Lb) units system;



Edit air absorption

Opens the Air absorption parameters Window

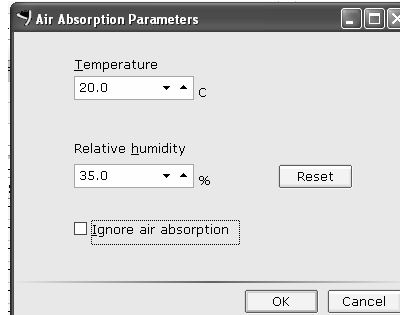

Important : please note that dBMIF curve remains unchanged with air absorption.

3D Mode / 2D Mode

Switches project from 2D to 3D Mode or opposite (see above). “2D” or “3D” are displayed next to toolbar as a reminder.

Help Menu

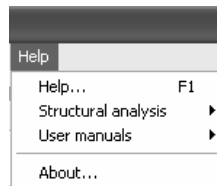

Help

Opens current GeoSoft Help Manual.

Structural Analysis

Opens NEXO Geo S8, Geo S12, Geo D or GeoT structural analysis PDF files.

User Manuals

Opens NEXO Geo S, Geo D or GEOT User Manual PDF files, with all setup instructions.

About Geosoft

Current GeoSoft Version.



NEXO

11/38

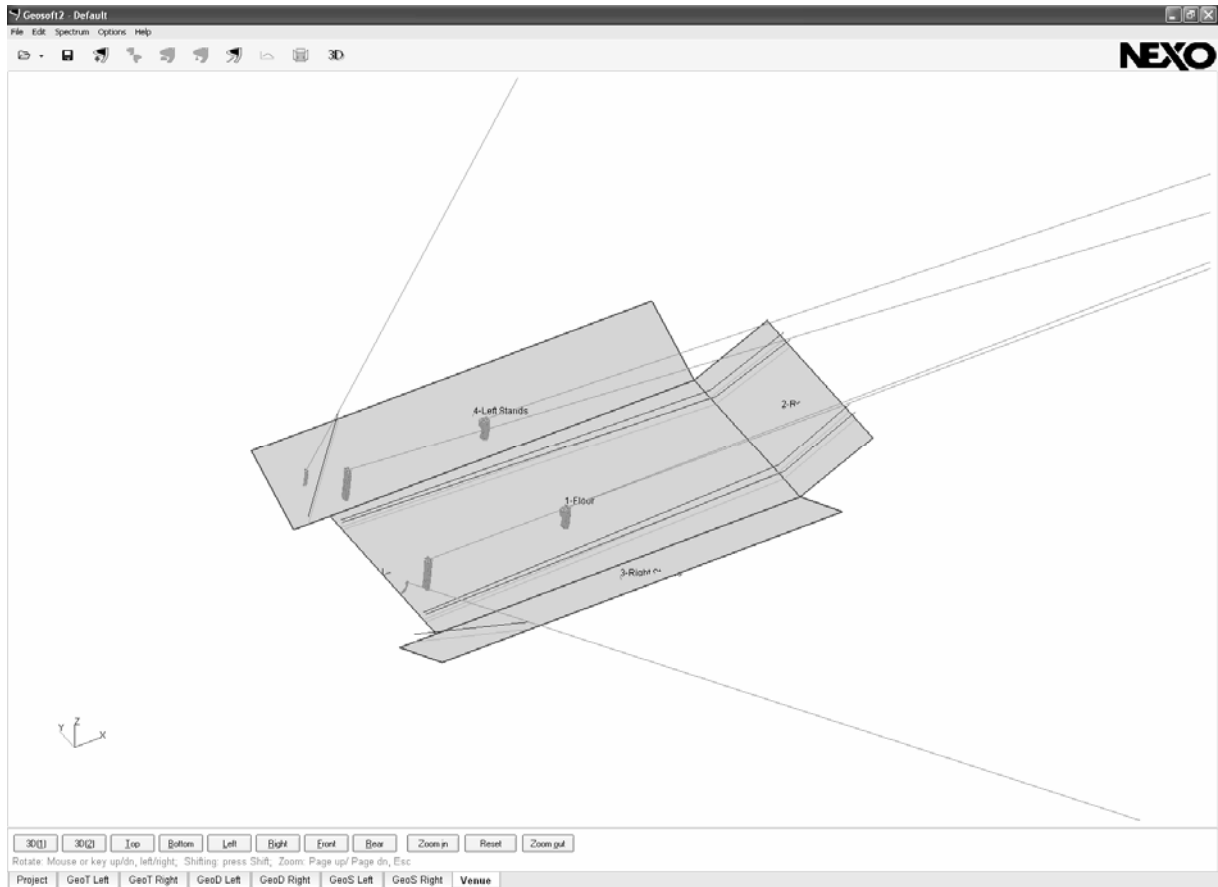

3D venue display

Edit Venue Planes

Opens tables to edit planes as below

#	Audience	Annotation	Vertex 1	Vertex 2	Vertex 3	Vertex 4
2	Seated	Rear Stands	50, 12.5, 0	50, -12.5, 0	50, -12.5, 5	50, 12.5, 5
3	Seated	Right Stands	-5, -12.5, 0	-5, -22.5, 5	50, -22.5, 5	50, -12.5, 0
4	Seated	Left Stands	-5, 22.5, 5	-5, 12.5, 0	50, 12.5, 0	50, 22.5, 5
5	Seated					

#	Audience	Annotation	(X) Depth 1	(Z) Height 1	(X) Depth 2	(Z) Height 2
1	Seated	Floor	0	0	50	0
2	Seated	Rear Stands	50	0	60	5
3	Seated	Right Stands	-5	2.5	50	2.5
4	Seated	Left Stands	-5	2.5	60	2.5

Edit Venue Planes Table 3D and 2D



Audience

Seated is 1.20 meter height mapping

Standing is 1.60 meter height mapping

No audience disables acoustic computations on selected plane, however, plane is still be displayed in Venue (typically, ceilings, walls).

Disabled disables both display and computations (this feature allows to enter various configurations in the same venue file)

Annotation

Annotation is Plane name

Vertex 1 to 4

Vertex 1 to 4 are to enter 4 plane corners coordinates. When double-clicking on selected vertex, following Input Window appears:

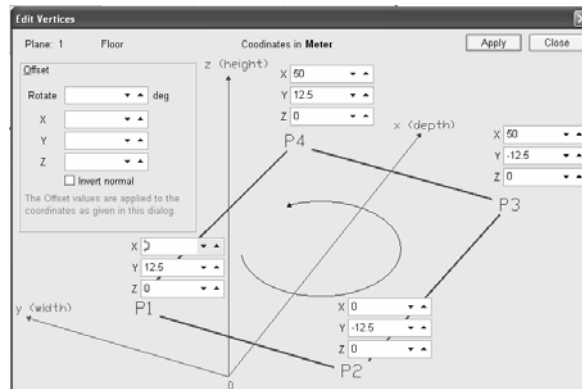

This window allows to enter X,Y and Z vertex coordinates, and to eventually rotate (around origin) or offset defined plane.

Values must be entered P1 to P4 going counter-clockwise.

If vertexes are entered in the wrong order (ie clockwise), no values will be displayed in Cluster Pressure Plot. These planes can be easily inverted with the "Invert Plane" function.

Reversed planes can be easily identified as being white when seen from top (instead of grey).

Menu

Menu opens below selection (also available on right-mouse click on a plane)

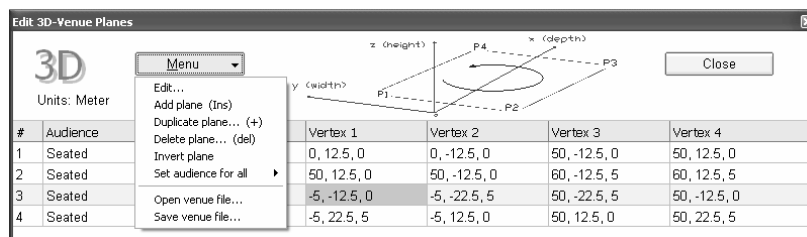

Edit Venue (3D Mode)

Opens Edit Vertices Window

NEXO

13/38



Add plane

Adds a new plane (with empty coordinates)

Duplicate plane

Opens below window, which allows rotating (around origin) or offsetting defined plane.

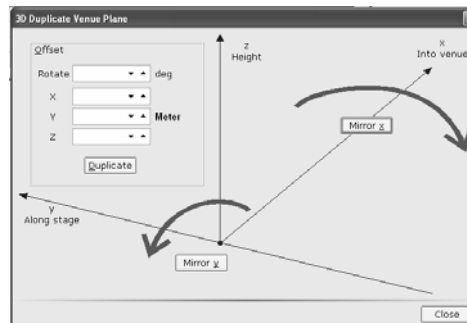

Delete Plane

Deletes selected plane

Invert Plane

Reverses P1 to P4 in P4 to P1 for proper plane orientation

Set Audience for all

No audience / Seated / Standing / Disabled defined simultaneously for all planes

Open Venue File

Opens .txt file (Geosoft2 Venue text format), .nxv file (Geosoft2 Nexo proprietary venue format) or .xar file (EASE 4™ Audience Export text format)

Importing Audience planes from Ease 4

To generate .xar files in Ease from the "Edit Project" page, select "File / Export Ascii File / Audience Areas". This will generate an .xar file, which Geosoft2 can import. Geosoft2 will automatically set the lower Z coordinates (height) to 0: cluster height might have to be adjusted accordingly, keeping in mind that Geosoft2 maps at 1.2m height (seated) or 1.6m height (standing).

Important: because Geosoft2 sets the lower plane at 0m height while importing from Ease .xar files, cluster rigging point z-coordinates might be different in Ease and Geosoft2. Double-check relative height from audience plane to cluster rigging point

Save Venue File

Saves .nxv file (Geosoft2 Nexo proprietary venue format)



Edit Venue (2D Mode)

When selecting « 2D Mode » in the Option menu, planes are defined by two points (X, Z) coordinates.

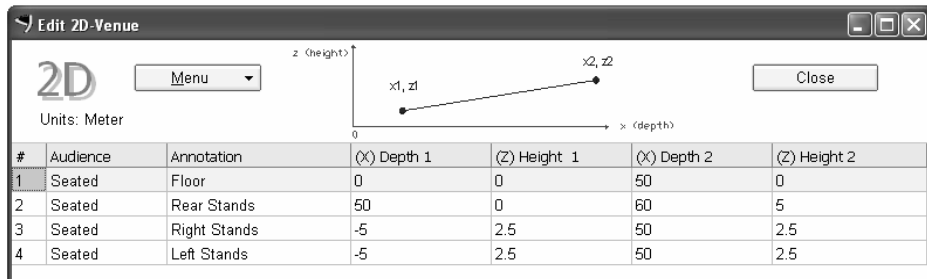

Working in 2D mode is highly recommended for fast configuration definition since only 4 values are to be entered instead of 12 in 3D mode.

Important: when switching from 3D Mode to 2D Mode, all clusters horizontal angles as well as venue Y coordinates will be lost.

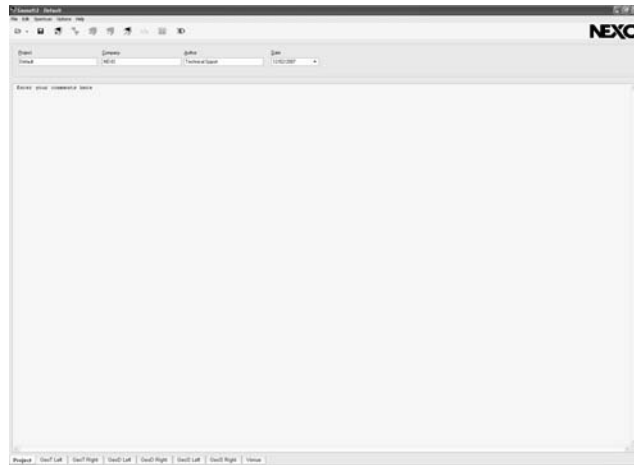

Project

Enter project name.

Company

Enter company name.

Author

Enter your name.

Date

Enter the date.

Text Window

Type your project comments here.

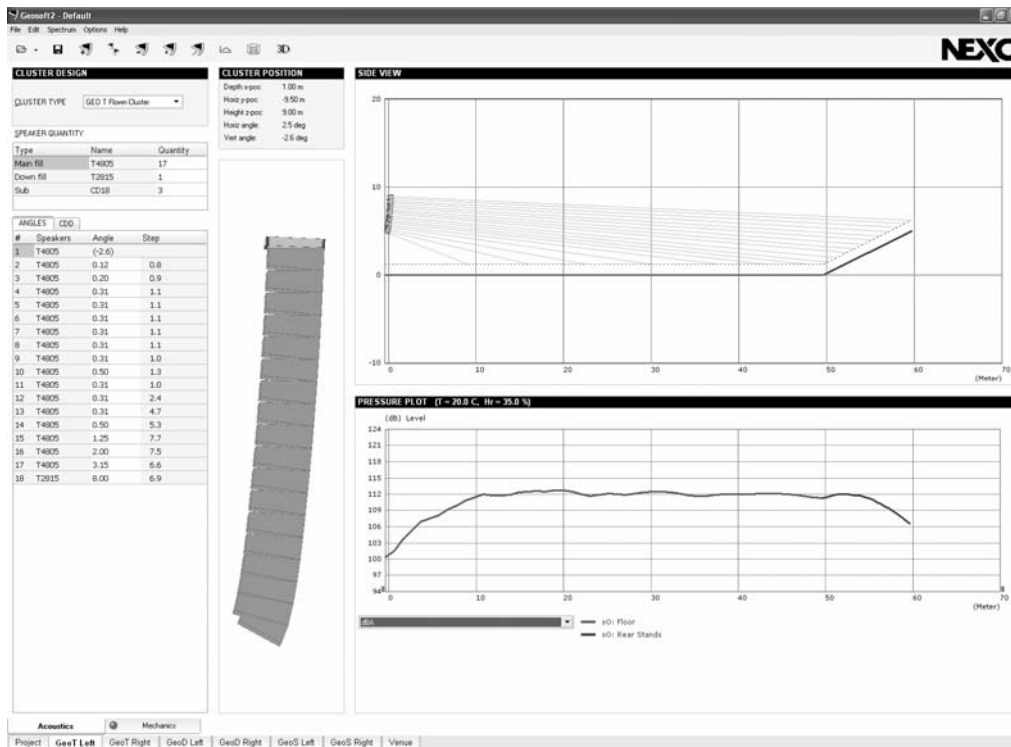

Cluster Type

Flown / Stacked NEXO GEO S8, GEO S12, GEO D or GEO T clusters

Speaker Quantity

Defines quantities for:

- NEXO GEO S805 / S830
- NEXO GEO S1210 / S1230
- NEXO GEO D10 / GEO SUB
- NEXO GEO T4805 / NEXO T2815 / CD18

Insert / Remove

This feature is accessible by right-mouse clicking while in the Inter-Angle page, or by positioning cursor where a speaker needs to be inserted or removed and then changing the speaker quantity.

Move Towards Bumper / Move Away Bumper

This feature is available on GeoS8, Geo S12 and GeoD, by right-mouse clicking in the Inter-Angle Page, or by clicking and dragging speaker #.

IMPORTANT: GeoS8, GeoS12 and GeoD mechanical computations are valid while positioning cabinet at any location in the cluster



Rig Angles Tab

CLUSTER DESIGN		
CLUSTER TYPE: GEO T Flown Cluster		
SPEAKER QUANTITY		
Type	Name	Quantity
Main fill	T4805	17
Down fill	T2815	1
Sub	CD18	3

ANGLES	CDD		
#	Speakers	Angle	Step
1	T4805	(-2.6)	
2	T4805	0.12	0.8
3	T4805	0.20	0.9
4	T4805	0.31	1.1
5	T4805	0.31	1.1
6	T4805	0.31	1.1
7	T4805	0.31	1.1
8	T4805	0.31	1.1
9	T4805	0.31	1.0
10	T4805	0.50	1.3
11	T4805	0.31	1.0
12	T4805	0.31	2.4
13	T4805	0.31	4.7
14	T4805	0.50	5.3
15	T4805	1.25	7.7
16	T4805	2.00	7.5
17	T4805	3.15	6.6
18	T2815	8.00	6.9

ANGLES	CDD	
#	Speakers	Horiz coverage
1	T4805	90
2	T4805	90
3	T4805	90
4	T4805	90
5	T4805	90
6	T4805	90
7	T4805	90
8	T4805	90
9	T4805	90
10	T4805	90
11	T4805	90
12	T4805	90
13	T4805	90
14	T4805	90
15	T4805	90
16	T4805	90
17	T4805	90
18	T2815	120

Vertical Angle Configuration

Horizontal Dispersion Configuration

Choices between the cabinets are :

GEO S8

- S805 to S805 : 0.31 - 0.50 - 0.80 – 1.25 – 2.00 – 3.15 – 5.00 degrees ;
- S805 to S830 : 17.5 degrees ;
- S830 to S830 : 17.5 -30 degrees ;

GEO S12

- S1210 to S1210:
0.20 - 0.31 - 0.50 - 0.80 – 1.25 – 2.00 – 3.15 – 5.00 – 6.25 – 8.00 – 10 degrees ;
- S1210 to S1230: 16 degrees;
- S1230 to S1230: (16) - 22.5 – 30 degrees;

NB: 16° is allowed for specific installations where high dBSPL values are required. However, bandwidth is then limited to 10 kHz.

GEO D

- D10 to D10 (or D10 to GEO SUB or GEO SUB to GEO SUB)
0.20 - 0.31 - 0.50 - 0.80 – 1.25 – 2.00 – 3.15 – 5.00 – 6.25 – 8.00 – 10 degrees ;

GEO T

- T4805 to T4805 : 0.12 – 0.20 - 0.31 - 0.50 - 0.80 – 1.25 – 2.00 – 3.15 – 5.00 degrees ;
- T4805 to T2815 : 6.30 - 8.00 –10.00 degrees ;
- T2815 to T2815 : 6.30 - 8.00 – 10.0 - 12.5 – 15.0 degrees.

Step

Non editable field ; gives the distance between adjacent cabinets targeted points on the audience.

NEXO

18/38



CDD

Allows to define horizontal coverage for each cabinet (GeoS8, Geo S12 and Geo D)

Cluster Position

CLUSTER POSITION	
Depth x-pos:	1.00 m
Horiz y-pos:	-9.50 m
Height z-pos:	9.00 m
Horiz angle:	2.5 deg
Vert angle:	-2.6 deg

Mouse Click inside the frame opens the Cluster Position Window (see above)

Pressure Plot and Frequency Response display

Pressure plot

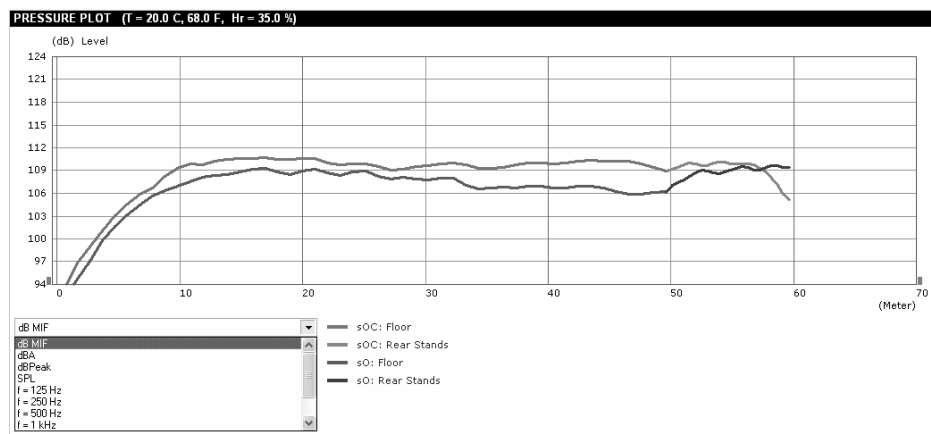

Displayed Pressure Levels curves are selectable and are :

- dB MIF, stands for dB "Make It Flat" ; for proper array curvature definition, this curve has to fit within 3 dB on the audience area. Please note that Air Absorption has no effect on dB MIF curve
- dBPeak, computed from 300 Hz to 3000 Hz with a 6 dB Peak Factor ;
- dBA, computed from 63 Hz to 16 kHz A-weighted ;
- dB SPL, summed from 63 Hz to 16 kHz, no weighting;
- dB SPL for each octave bands from 125 Hz to 8 kHz (63 Hz display is available for GeoSub)

Plots can be stored in memory by double-clicking on the audience name below display scrolling menu.

Plots in memory can be erased by selecting audience name below display scrolling menu, and pressing the "suppress" key.

Frequency Response

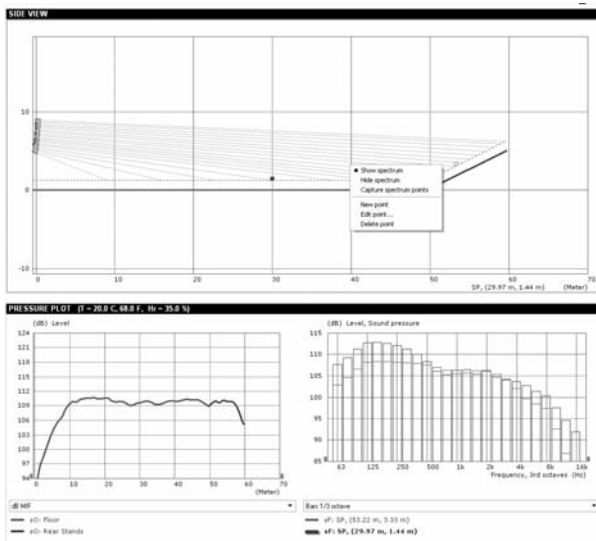

SP Point

Position

Units: Meter

Horizontal value
53.218

Vertical value
3.331

Frequency plot becomes available by selecting “Show Spectrum” in the Spectrum Menu (or Right Mouse Click on Side View).

Points for which frequency response will be computed are defined by Right Mouse clicking on Side View. SP Point window allows then to enter coordinates.

Curves can be displayed Continuous, Octave Bands, 1/3rd Octave Bands or 1/6th Octave Bands.

Plots can be stored in memory by double-clicking on the point coordinates below display scrolling menu.

Plots in memory can be erased by selecting point coordinates below display scrolling menu, and pressing the “suppress” key.

Plot Colors can be changed by clicking and dragging point coordinates below display; below figure is then displayed:

Plot Curves

Assign curve to

Left y-axis Right y-axis

Simulation conditions

- test signal : IEC268 filtered Pink Noise (similar spectral content than music);
- free-field ;

Important :

- for distances superior to 80 meters (~260 feet), temperature, wind and hygrometry gradients do not allow to make any reliable acoustic prediction.
- GeoSoft simulation does not take in to account any room contribution (floor reflection, reverberation...), nor another cluster contribution. Consequently, all dB values are default values that might increase from 3 to 6dB.



GEO S8 CLUSTER MECHANICAL WINDOW

Configuration Settings

SETTINGS	
Rigging mode	CD12 link bar
Wind Beaufort 8	From rear
Cluster secured	No

Rigging Mode

NEXO GEO S8:

- Bumper Only (GeoS8 without CD12)
- Extension Bar at the back (GeoS8 without CD12)
- Extension Bar at the Front (GeoS8 without CD12)
- CD12 Link Bar (GeoS8 with CD12 Only)

Wind Beaufort 8

Corresponds to a 20.7 m/s wind. Options are:

- No Wind
- Wind from the back of the cluster
- Wind from the front of the cluster

Lateral wind is considered to have no influence on investigated forces.

Cluster Secured

Windforce distribution on cluster depends on how it is secured. Investigated cases are:

- No (cluster can rotate freely)
- Bottom: cluster secured at the bottom to avoid vertical rotation
- Top: top bumper rigidly secured to avoid vertical rotation (bottom unsecured)



Cluster Dimensions and Weight

CLUSTER	
Cluster type	GEO 8 Flown Cluster
S805 (Array) Qty	7
S830 (Array) Qty	1
CD12 (Sub) Qty	2
Bumper angle	-11.00 deg
Lower cabinet angle	-38.19 deg
Cluster height (H)	2.00 m
Cluster width (W)	0.60 m
Cluster depth (D)	1.50 m
Rear rigging point height	9.09 m
Front rigging point height	9.13 m
Lower cabinet height	7.09 m
Distance between rigging points (A)	1.35 m
Gravity center to front rigging point (A2)	0.54 m
Gravity center to rear rigging point (A1)	0.82 m
Clearance from front rigging point (C2)	0.10 m
Clearance from rear rigging point (C1)	0.10 m
Cluster weight (M)	209.00 kg
Weight on front rigging point (M2)	126.36 kg
Weight on rear rigging point (M1)	82.64 kg

- Cluster Type : as in Acoustic Page
- GEO Quantity: as in Acoustic Page
- CD12 Quantity: as in Acoustic Page
- Bumper Angle: Angle in relation to Horizontal Line, CCW.
- Lower Cabinet Angle;
- Cluster Height: Overall Height including rigging accessories;
- Cluster Width: Overall Width including rigging accessories;
- Cluster Depth: Overall Depth including rigging accessories;
- Rear Rigging Point Height: Front Bumper Rigging Point height referenced to Z=0;
- Front Rigging Point Height: Rear Bumper Rigging Point height referenced to Z=0;
- Lower Cabinet Height: referenced to Z=0;
- Distance between rigging points: horizontal distance from Rear to Front Bumper Rigging Points
- Gravity Center to Front Rigging Point: horizontal distance from Gravity Center to Front Rigging Point (must be positive and less than distance between rigging points, turns red if gravity center off rigging points, turns orange if 5% to the limits)
- Gravity Center to Rear Rigging Point: horizontal distance from Gravity Center to Rear Rigging Point (must be positive and less than distance between rigging points, turns red if gravity center off rigging points, turns orange if 5% to the limits)
- Clearance from Front Rigging Point: minimum free space required ahead of Front Rigging Point
- Clearance from Rear Rigging Point: minimum free space required behind Rear Rigging Point
- Cluster Weight: total cluster weight including rigging accessories
- Weight on Front Rigging Point: must be positive and less than total Cluster Weight (turns red if gravity center off rigging points, turns orange if 5% to the limits)
- Weight on Rear Rigging Point: must be positive and less than total Cluster Weight (turns red if gravity center off rigging points, turns orange if 5% to the limits)



Mechanical Forces

FORCES	
Allowed loads on bumper rear points S1	-13.70 kN / 9.00 kN
Applied loads on bumper rear points S1	1.65 kN
Allowed loads on bumper front points S2	-13.70 kN / 7.10 kN
Applied loads on bumper front points S2	-0.84 kN
Allowed moment on extension bar	2.40 kNm
Applied moment on extension bar (M0)	0.53 kNm
Allowed moment on link bar	2.40 kNm
Applied moment on link bar (M0)	0.53 kNm
Allowed load on CD12 flying rails	1.90 kN
Applied load on CD12 flying rails (FS3)	0.36 kN
Applied wind force on cluster (Fw)	0.25 kN

- Allowed Loads on Bumper Rear Points S1: theoretical pressure/tensile force values confirmed with destruction tests
- Applied Loads on Bumper Rear Points S1: configuration applied value (turns red if outside limits)
- Allowed Loads on Bumper Front Points S2: theoretical pressure/tensile values confirmed with destruction tests
- Applied Loads on Bumper Front Points S2: configuration applied value (turns red if outside limits)
- Allowed Moment on Extension Bar (closed cross-section): theoretical maximum moment force before bending, confirmed with destruction tests
- Applied Moment on Extension Bar (closed cross-section): configuration applied value (turns red outside above limits)
- Allowed Moment on Link Bar: theoretical maximum moment force before bending, confirmed with destruction tests
- Applied Moment on Link Bar: configuration applied value (turns red if outside limits)
- Allowed Load on CD12 flying rails: theoretical tensile force values
- Applied Load on CD12 flying rails: configuration applied values (turns red if outside limits)
- Wind force applied on cluster:
 - Rear or Front force applied when wind is present (Beaufort Scale = 8)
- Wind Offset Angle: Vertical Cluster rotation related to wind forces

Angle Sequence

- Delta: Inter Cabinets Angle Sequence
- Sum: Cumulative Angle Sequence (which takes wind effect into account)

ANGLE SEQUENCE		
#	Delta	Sum
Bumper	-11.00	0.76
1	2.00	-1.24
2	3.15	-4.39
3	3.15	-7.54
4	3.15	-10.69
5	5.00	-15.69
6	5.00	-20.69
7	17.50	-38.19



Working Load – Safety Factor – Lifting Factor

WORKING LOAD - SAFETY FACTOR	
% allowed working load (safety factor 1.5)	22
Safety factor for 100% allowed working load	6.8
Lifting factor	1.0

Percentage of Allowed Working Load

Is based on the ratio of all applied moments and forces to their limit

Is determined by the component which is the closest to its limits

Corresponds to a Safety Factor of 1.5 when is equal to 100%

Must not be above 100% (turns red if so)

Safety Factor for 100% of Allowed Working Load

Cluster configuration Safety Factor

Must not be below 1.5 (turns red if so)

Can be used to comply with local regulations

Lifting Factor

Is 1.2 if no wind (where setup typically occurs)

Is 1 if wind (where setup is forbidden)

Caution – Warning Messages

Warning Messages for Rigging feasibility and safety.

Permanently displayed messages

CAUTION
READ USER MANUAL PRIOR TO OPERATION
CHECK LOCAL REGULATIONS ON LOUDSPEAKER RIGGING SYSTEM
ENSURE ANGLES SETTINGS ARE IDENTICALLY ON BOTH SIDES
CHECK WITHOUT WINDFORCES

Conditional messages

These messages are related to unfeasible or unsafe loads:

FRONT RIGGING POINT NOT IN TENSION LOAD
UNSAFE LOADING
UNSAFE LOAD FOR LINK BAR
UNSAFE LOAD FOR GEO S BUMPER
SAFETY FACTOR TOO LOW

Cluster Drawings

Drawings are displayed to show computed points and cluster setup configurations.

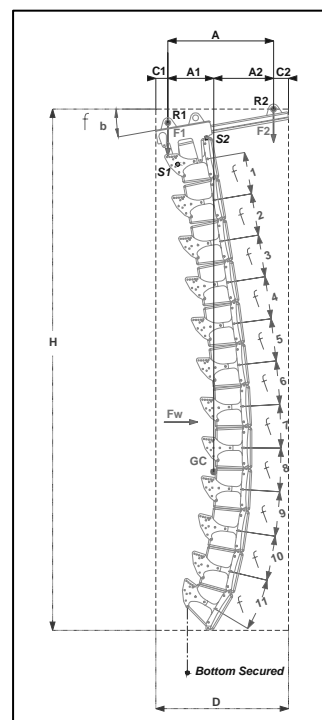
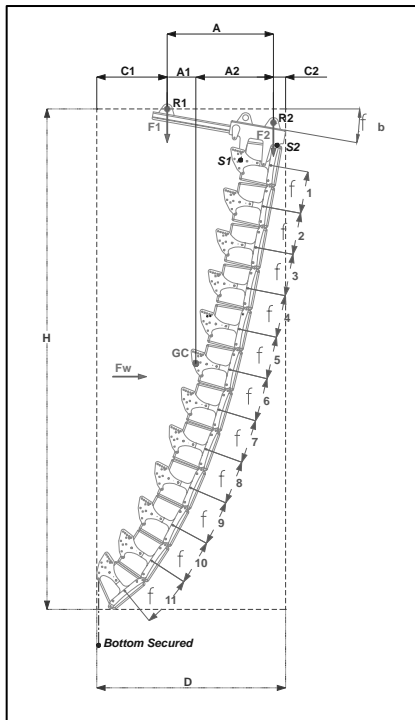
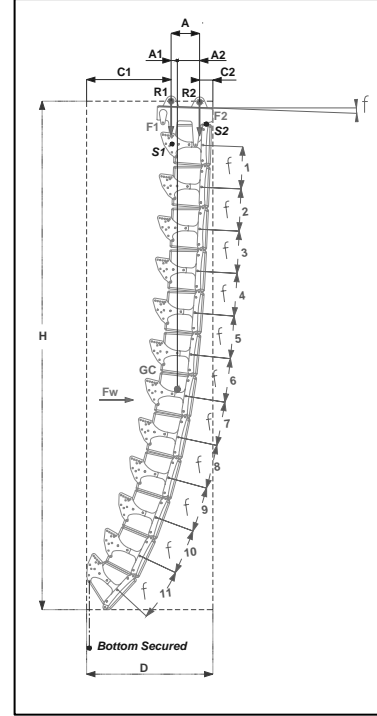
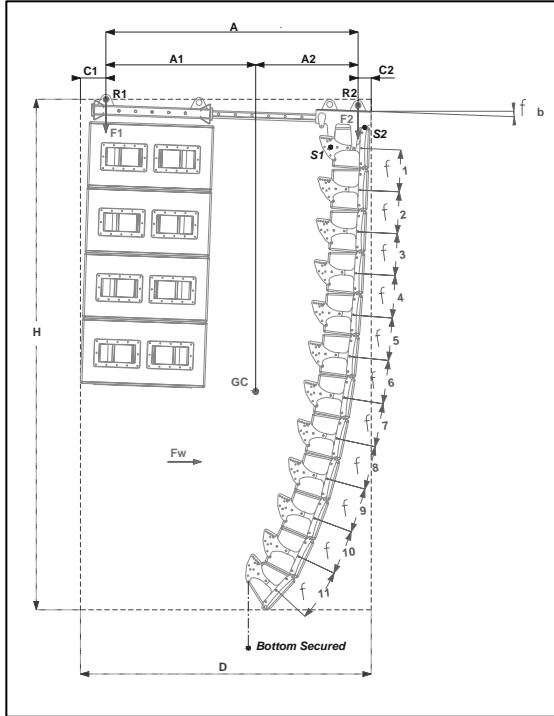



GEO S12 CLUSTER MECHANICAL WINDOW

Configuration Settings

SETTINGS	
Rigging mode	Single motor
Rigging point position	# -6
Actual bumper angle	-4.66 deg
Bumper angle error	0.34 deg
Wind Beaufort 8	No wind
Cluster secured	No

Single Motor / One Rigging Point

SETTINGS	
Rigging mode	Two motors
Rear rigging point	# -17
Front rigging point	# 17
Wind Beaufort 8	No wind
Cluster secured	No

Two Motors / Two Rigging Points

Rigging Mode

NEXO GEO S12:

- One motor or
- Two motors

Rigging point position

- When using one motor, gives the bumper hole position to achieve required bumper angle (turns red if gravity center is off hole range, turns orange when 5% to the limit).

Rear rigging point

- When using two motors, gives the bumper rear hole position (must be #-17)

Front rigging point

- When using two motors, gives the bumper front hole position (must be #17)

Wind Beaufort 8

- Not implemented at this time.

Cluster Secured

- Not implemented at this time



Cluster Dimensions and Weight

CLUSTER	
Cluster type	GEO S12 Flown Cluste
S1210 (Array) Qty	7
S1230 (Array) Qty	1
Bumper angle	-5.40 deg
Lower cabinet angle	-29.91 deg
Cluster height (H)	2.89 m
Cluster width (W)	0.80 m
Cluster depth (D)	1.02 m
Rigging point height	6.14 m
Lower cabinet height	3.31 m
Front clearance from rigging point (C2)	0.03 m
Rear clearance from rigging point (C1)	0.39 m
Cluster weight (M)	279.37 kg

Single Motor / One Rigging Point

- Cluster Type : as in Acoustic Page
- GEO S1210 Quantity: as in Acoustic Page
- GEO S1230 Quantity: as in Acoustic Page
- Bumper Angle: Angle in relation to Horizontal Line, CCW.
- Lower Cabinet Angle: bottom cabinet axis angle
- Cluster Height: Overall Height including rigging accessories;
- Cluster Width: Overall Width including rigging accessories;
- Cluster Depth: Overall Depth including rigging accessories;
- Rigging Point Height: Bumper Single Rigging Point height referenced to Z=0;
- Rear Rigging Point Height: Bumper Rigging Point #17 height referenced to Z=0;
- Front Rigging Point Height: Bumper Rigging Point #17 height referenced to Z=0;
- Lower Cabinet Height: referenced to Z=0;
- Distance between rigging points: horizontal distance from Rear to Front Bumper Rigging Points
- Gravity Center to Front (Rear) Rigging Point: horizontal distance from Gravity Center to Front (Rear) Rigging Point (must be positive and less than distance between rigging points, turns red if gravity center off rigging points, turns orange if 5% to the limits)
- Front (Rear) Clearance from Rigging Point: minimum free space required ahead of (behind) single rigging point;
- Clearance from Front (Rear) Rigging Point: minimum free space required ahead of Front (behind Rear) Rigging Point
- Clearance from Rear Rigging Point: minimum free space required behind Rear Rigging Point
- Cluster Weight: total cluster weight including rigging accessories
- Weight on Front and Rear Rigging Point: must be positive and less than total Cluster Weight (turns red if gravity center off rigging points, turns orange if 5% to the limits)

CLUSTER	
Cluster type	GEO S12 Flown Cluste
S1210 (Array) Qty	7
S1230 (Array) Qty	1
Bumper angle	-5.40 deg
Lower cabinet angle	-29.91 deg
Cluster height (H)	2.89 m
Cluster width (W)	0.80 m
Cluster depth (D)	1.02 m
Rear rigging point height	6.15 m
Front rigging point height	6.10 m
Lower cabinet height	3.31 m
Distance between rigging points (A)	0.59 m
Gravity center to front rigging point (A2)	0.42 m
Gravity center to rear rigging point (A1)	0.18 m
Clearance from front rigging point (C2)	0.03 m
Clearance from rear rigging point (C1)	0.39 m
Cluster weight (M)	279.37 kg
Weight on front rigging point (M2)	83.00 kg
Weight on rear rigging point (M1)	196.37 kg

Two Motors / Two Rigging Points



Mechanical Forces

Not implemented at this time

Angle Sequence

- Delta: Inter Cabinets Angle Sequence
- Sum: Cumulative Angle Sequence (which takes wind effect into account)

ANGLE SEQUENCE		
#	Delta	Sum
Bumper	-11.00	0.76
1	2.00	-1.24
2	3.15	-4.39
3	3.15	-7.54
4	3.15	-10.69
5	5.00	-15.69
6	5.00	-20.69
7	17.50	-38.19

Working Load – Safety Factor – Lifting Factor

Not implemented at this time

Caution – Warning Messages

Warning Messages for Rigging feasibility and safety.

Permanently displayed messages

CAUTION
READ USER MANUAL PRIOR TO OPERATION
CHECK LOCAL REGULATIONS ON LOUDSPEAKER RIGGING SYSTEM
ENSURE ANGLES SETTINGS ARE IDENTICALLY ON BOTH SIDES

Conditional messages

These messages are related to unfeasible loads:

GRAVITY CENTER OFF THE BUMPER
ANGLE OUT OF RANGE

Please note that safety warnings are not implemented at this time.

Cluster Drawings

Drawings are displayed to show computed points and cluster setup configurations.

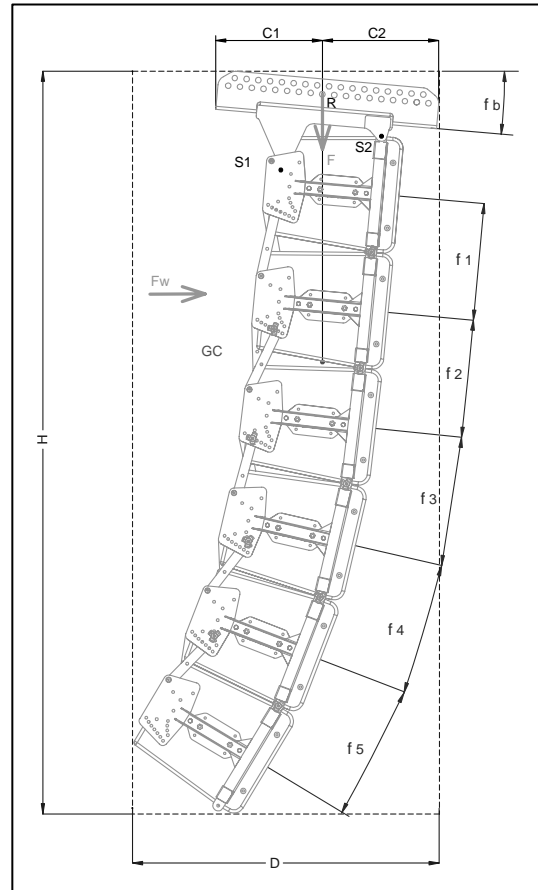
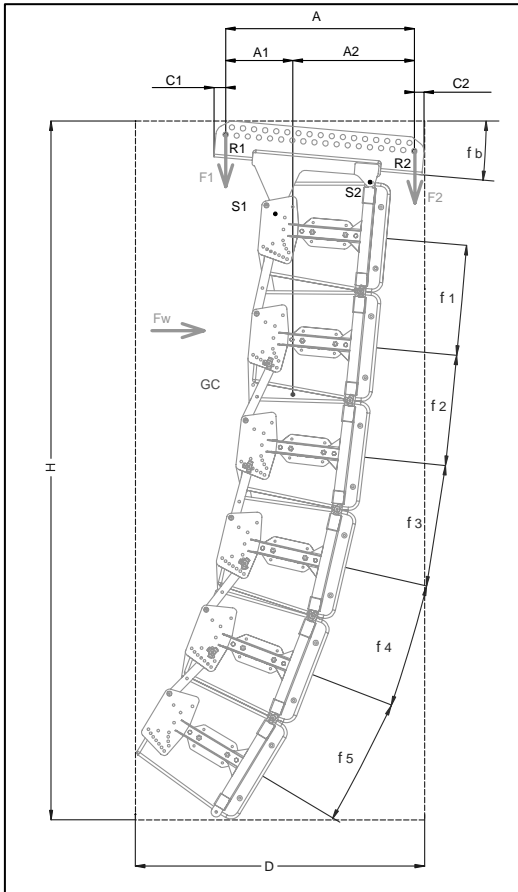



GEO D CLUSTER MECHANICAL WINDOW

Configuration Settings

SETTINGS	
Rigging top	Bumper + ExBar1
Rigging bottom	Bottom-Bumper
Chain lever hoist	Leva750
Wind Beaufort 8	No wind
Cluster secured	No

Rigging top (case dependent, selectable)

1 Motor + EXBar1: GEO Bridle + GEOD bumper + Short Extension Bar + Wheel (only for GEO D clusters)

2 Motors + EXBar1: GEOD bumper + Short Extension Bar (only for GEO D clusters)

2 Motors + EXBar2: GEOD bumper + Long Extension Bar (for GEO D and GEO SUB clusters)

Rigging bottom (case dependent, automatic)

Bottom-Bumper: GEOD bottom bumper (only for GEO D or combined GEO D / GEO SUB clusters)

Bumper + ExBar3: GEO SUB bottom bumper (only for GEO SUB clusters)

Chain lever hoist (selectable)

Leva 750: for up to 7.5 kN compression force

Leva 1500: from 7.5 kN to 15 kN compression force

NB: when 1 motor, LEVA750 is mandatory

Wind Beaufort 8

Corresponds to a 20.7 m/s wind. Options are:

- No Wind
- Wind from the back of the cluster
- Wind from the front of the cluster

Lateral wind is considered to have no influence on investigated forces.

Cluster Secured

Windforce distribution on cluster depends on how it is secured. Investigated cases are:

- No (cluster can rotate freely)
- Bottom: cluster secured at the bottom to avoid vertical rotation

NB: when 1 motor, securing bottom cluster is mandatory



Cluster Dimensions and Weight (2 rigging points)

CLUSTER	
Cluster type	GEO D Flown Cluster
Geo Sub (Array) Qty	4
D-10 (Array) Qty	12
Bumper angle	0.50 deg
Lower cabinet angle	-5.93 deg
Cluster height (H)	6.60 m
Cluster width (W)	0.74 m
Cluster depth (D)	1.46 m
Rear rigging point height	9.10 m
Front rigging point height	9.11 m
Lower cabinet height	2.64 m
Distance between rigging points (A)	1.08 m
Gravity center to front rigging point (A2)	0.25 m
Gravity center to rear rigging point (A1)	0.83 m
Clearance from front rigging point (C2)	0.19 m
Clearance from rear rigging point (C1)	0.18 m
Cluster weight (M)	1106.40 kg
Weight on front rigging point (M2)	852.10 kg
Weight on rear rigging point (M1)	254.30 kg

- Cluster Type : as in Acoustic Page
- GEO SUB: as in Acoustic Page
- GEO D10: as in Acoustic Page
- Bumper Angle: Angle in relation to Horizontal Line, CCW.
- Lower Cabinet Angle;
- Cluster Height: Overall Height including rigging accessories;
- Cluster Width: Overall Width including rigging accessories;
- Cluster Depth: Overall Depth including rigging accessories;
- Rear Rigging Point Height: Rear Bumper Rigging Point height referenced to Z=0;
- Front Rigging Point Height: Front Bumper Rigging Point height referenced to Z=0;
- Lower Cabinet Height: referenced to Z=0;
- Distance between rigging points: horizontal distance from Rear to Front Bumper Rigging Points
- Gravity Center to Front Rigging Point: horizontal distance from Gravity Center to Front Rigging Point (must be positive and less than distance between rigging points, turns red if gravity center off rigging points, turns orange if 5% to the limits)
- Gravity Center to Rear Rigging Point: horizontal distance from Gravity Center to Rear Rigging Point (must be positive and less than distance between rigging points, turns red if gravity center off rigging points, turns orange if 5% to the limits)
- Clearance from Front Rigging Point: minimum free space required ahead of Front Rigging Point
- Clearance from Rear Rigging Point: minimum free space required behind Rear Rigging Point
- Cluster Weight: total cluster weight including rigging accessories
- Weight on Front Rigging Point: must be positive and less than total Cluster Weight (turns red if gravity center off rigging points, turns orange if 5% to the limits)
- Weight on Rear Rigging Point: must be positive and less than total Cluster Weight (turns red if gravity center off rigging points, turns orange if 5% to the limits)



Mechanical Forces

FORCES	
Allowed force on bumper front rigging point R2	23.60 kN
Applied force on bumper front rigging point R2	8.52 kN
Allowed force on bumper rear rigging point R1	23.60 kN
Applied force on bumper rear rigging point R1	2.54 kN
Allowed force on bumper front connecting point S2	-5.00 kN / 15.00 kN
Applied force on bumper front connecting point S2	3.81 kN
Allowed force on bumper rear connecting point S1	-5.00 kN / 15.00 kN
Applied force on bumper rear connecting point S1	0.00 kN
Allowed force on cabinet front connecting point S2	-15.00 kN / 15.00 kN
Applied force on cabinet front connecting point S2	0.44 kN / 3.55 kN
Allowed force on cabinet rear connecting point S1	-15.00 kN / 15.00 kN
Applied force on cabinet rear connecting point S1	-1.41 kN / -0.17 kN
Allowed perpendicular force on reinforcement bar	3.55 kN
Applied perpendicular force on reinforcement bar	0.22 kN
Allowed force on Kelping chain	7.50 kN
Applied force on Kelping chain	2.75 kN
Allowed force on cabinet connection to bottom bumper	15.00 kN
Applied force on cabinet connection to bottom bumper	2.74 kN

- Allowed force on bumper front rigging point R2: theoretical tensile force value limit
- Applied force on bumper front rigging point R2: applied value (turns red if outside limits)
- Allowed force on bumper rear rigging point R1: theoretical tensile force value limit
- Applied force on bumper rear point rigging R1: applied value (turns red if outside limits)
- Allowed force on bumper front connecting point to top cabinet S2: theoretical pressure/tensile force value limit
- Applied force on bumper front connecting point to top cabinet S2: applied value (turns red if outside limits)
- Allowed force on bumper rear connecting point to top cabinet S1: theoretical pressure/tensile force value limit
- Applied force on bumper rear connecting point to top cabinet S1: applied value (turns red if outside limits)
- Allowed force on front connecting point S2: theoretical pressure/tensile force value limit
- Applied force on front connecting point S2: applied value (turns red if outside limits)
- Allowed force on rear connecting point S1: theoretical pressure/tensile force value limit
- Applied force on rear connecting point S1: applied value (turns red if outside limits)
- Allowed perpendicular force on reinforcement bar: theoretical pressure/tensile limits for side metal parts
- Applied perpendicular force on reinforcement bar: applied value (turns red if outside limits)
- Allowed force on Kelping Chain: compression force theoretical limit
- Applied force on Kelping Chain: applied value (turns red if outside limits)
- Allowed force on cabinet connection to bottom cabinet: theoretical limit
- Applied force on cabinet connection to bottom cabinet: applied value (turns red if outside limits)



Cluster Dimensions and Weight (1 rigging point)

CLUSTER	
Cluster type	GEO D Flown Cluster
Geo Sub (Array) Qty	0
D-10 (Array) Qty	6
Bumper angle	-1.00 deg
Lower cabinet angle	-23.55 deg
Bridle front leg to bumper angle	73.43 deg
Bridle rear leg to bumper angle	64.18 deg
Bridle front leg to rear leg angle	42.39 deg
Cluster height (H)	2.45 m
Cluster width (W)	0.74 m
Cluster depth (D)	1.03 m
Rigging point height	9.96 m
Lower cabinet height	6.82 m
Front clearance from rigging point (C2)	0.45 m
Rear clearance from rigging point (C1)	0.67 m
Cluster weight (M)	412.40 kg

- Cluster Type : as in Acoustic Page
- GEO D10: as in Acoustic Page
- Bumper Angle: Angle in relation to Horizontal Line, CCW.
- Lower Cabinet Angle;
- Bridle Front leg to bumper angle: enclosed angle between the two
- Bridle Rear leg to bumper angle: enclosed angle between the two
- Bridle front leg to rear leg angle: enclosed angle between the two
- Cluster Height: Overall Height including rigging accessories;
- Cluster Width: Overall Width including rigging accessories;
- Cluster Depth: Overall Depth including rigging accessories;
- Rigging Point Height: Bridle rigging point height;
- Lower Cabinet Height: referenced to Z=0;
- Clearance from Front Rigging Point: minimum free space required ahead of Front Rigging Point
- Clearance from Rear Rigging Point: minimum free space required behind Rear Rigging Point
- Cluster Weight: total cluster weight including rigging accessories



Mechanical Forces

FORCES	
Allowed force on bumper front rigging point R2	23.60 kN
Applied force on bumper front rigging point R2	8.52 kN
Allowed force on bumper rear rigging point R1	23.60 kN
Applied force on bumper rear rigging point R1	2.54 kN
Allowed force on bumper front connecting point S2	-5.00 kN / 15.00 kN
Applied force on bumper front connecting point S2	3.81 kN
Allowed force on bumper rear connecting point S1	-5.00 kN / 15.00 kN
Applied force on bumper rear connecting point S1	0.00 kN
Allowed force on cabinet front connecting point S2	-15.00 kN / 15.00 kN
Applied force on cabinet front connecting point S2	0.44 kN / 3.55 kN
Allowed force on cabinet rear connecting point S1	-15.00 kN / 15.00 kN
Applied force on cabinet rear connecting point S1	-1.41 kN / -0.17 kN
Allowed perpendicular force on reinforcement bar	3.55 kN
Applied perpendicular force on reinforcement bar	0.22 kN
Allowed force on Kelping chain	7.50 kN
Applied force on Kelping chain	2.75 kN
Allowed force on cabinet connection to bottom bumper	15.00 kN
Applied force on cabinet connection to bottom bumper	2.74 kN

- Allowed force on bumper front rigging point R2: theoretical tensile force value limit
- Applied force on bumper front rigging point R2: applied value (turns red if outside limits)
- Allowed force on bumper rear rigging point R1: theoretical tensile force value limit
- Applied force on bumper rear point rigging R1: applied value (turns red if outside limits)
- Allowed force on bumper front connecting point to top cabinet S2: theoretical pressure/tensile force value limit
- Applied force on bumper front connecting point to top cabinet S2: applied value (turns red if outside limits)
- Allowed force on bumper rear connecting point to top cabinet S1: theoretical pressure/tensile force value limit
- Applied force on bumper rear connecting point to top cabinet S1: applied value (turns red if outside limits)
- Allowed force on front connecting point S2: theoretical pressure/tensile force value limit
- Applied force on front connecting point S2: applied value (turns red if outside limits)
- Allowed force on rear connecting point S1: theoretical pressure/tensile force value limit
- Applied force on rear connecting point S1: applied value (turns red if outside limits)
- Allowed perpendicular force on reinforcement bar: theoretical pressure/tensile limits for side metal parts
- Applied perpendicular force on reinforcement bar: applied value (turns red if outside limits)
- Allowed force on Kelping Chain: compression force theoretical limit
- Applied force on Kelping Chain: applied value (turns red if outside limits)
- Allowed force on cabinet connection to bottom cabinet: theoretical limit
- Applied force on cabinet connection to bottom cabinet: applied value (turns red if outside limits)



Angle Sequence

- Delta: Inter Cabinets Angle Sequence
- Sum: Cumulative Angle Sequence

ANGLE SEQUENCE		
#	Delta	Sum
Bumper	0.50	0.50
1	0.20	0.30
2	0.20	0.10
3	0.20	-0.10
4	0.20	-0.30
5	0.32	-0.62
6	0.32	-0.93
7	0.32	-1.25
8	0.32	-1.56
9	0.32	-1.88
10	0.32	-2.19
11	0.32	-2.50
12	0.32	-2.82
13	0.32	-3.13
14	0.80	-3.94
15	2.00	-5.93

Working Load – Safety Factor – Lifting Factor

WORKING LOAD - SAFETY FACTOR	
GEOD Cluster	
% allowed working load (safety factor 4)	37
Safety factor for 100% allowed working load	10.8

GeoD cluster - Percentage of Allowed Working Load

Is based on the ratio of all applied moments and forces to their limit

Is determined by the component which is the closest to its limits

Corresponds to a Safety Factor of 4 when is equal to 100%

Must not be above 100% (turns red if so)

GeoD cluster - Safety Factor for 100% of Allowed Working Load

Cluster configuration Safety Factor

Must not be below 4 (turns red if so)

Can be used to comply with local regulations



Caution – Warning Messages

Warning Messages for Rigging feasibility and safety.

Permanently displayed messages

CAUTION

READ USER MANUAL PRIOR TO OPERATION
CHECK LOCAL REGULATIONS ON LOUDSPEAKER RIGGING SYSTEM
ENSURE ANGLES SETTINGS ARE IDENTICALLY ON BOTH SIDES
CHECK WITHOUT WINDFORCES

Conditional messages

These messages are related to unfeasible or unsafe loads:

FRONT RIGGING POINT NOT IN TENSION LOAD
UNSAFE LOAD FOR GEOT CLUSTER
UNSAFE LOAD FOR CD18 CLUSTER
SAFETY FACTOR TOO LOW

Cluster Drawings

Drawings are displayed to show computed points and cluster setup configurations.

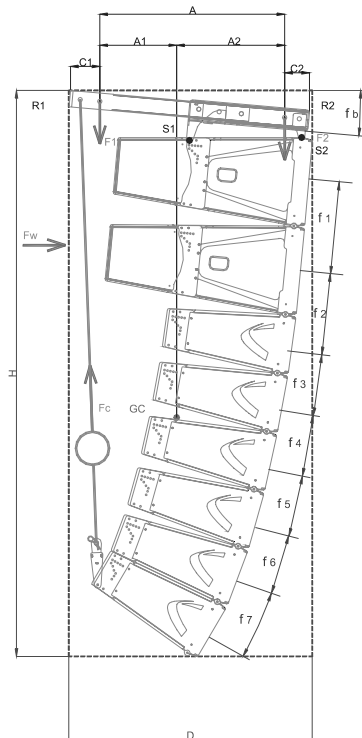

NEXO

36/38



GEO T CLUSTER MECHANICAL WINDOW

Configuration Settings

SETTINGS	
Rigging mode	Bumper only (tens
Wind Beaufort 8	No wind
Cluster secured	-

Rigging Mode

NEXO GEO T

- Bumper Only (Tension Mode)
- Bumper + Half Kelping Beam (Tension mode), which allows greater distance between rigging points
- Compression Mode + 20° Kelping Beam
- Compression Mode + Half Kelping Beam

Wind Beaufort 8

Corresponds to a 20.7 m/s wind. Options are:

- No Wind
- Wind from the back of the cluster
- Wind from the front of the cluster

Lateral wind is considered to have no influence on investigated forces.

Cluster Secured

It is assumed that wind cannot rotate cluster, and that therefore cluster does not need to be secured



Cluster Dimensions and Weight

CLUSTER	
Cluster type	GEO T Flown Cluster
T4805 (Array) Qty	17
T2815 (Array) Qty	1
CD18 (Sub) Qty	2
Bumper angle	-2.60 deg
Lower cabinet angle	-21.16 deg
Cluster height (H)	4.69 m
Cluster width (W)	0.90 m
Cluster depth (D)	1.07 m
Rear rigging point height	9.26 m
Front rigging point height	9.24 m
Lower cabinet height	4.58 m
Distance between rigging points (A)	0.55 m
Gravity center to front rigging point (A2)	0.39 m
Gravity center to rear rigging point (A1)	0.16 m
Clearance from front rigging point (C2)	0.11 m
Clearance from rear rigging point (C1)	0.41 m
Cluster weight (M)	975.00 kg
Weight on front rigging point (M2)	278.46 kg
Weight on rear rigging point (M1)	696.54 kg

- Cluster Type : as in Acoustic Page
- GEO Quantity: as in Acoustic Page
- CD18 Quantity: as in Acoustic Page
- Bumper Angle: Angle in relation to Horizontal Line, CCW.
- Lower Cabinet Angle;
- Cluster Height: Overall Height including rigging accessories;
- Cluster Width: Overall Width including rigging accessories;
- Cluster Depth: Overall Depth including rigging accessories;
- Rear Rigging Point Height: Rear Bumper Rigging Point height referenced to Z=0;
- Front Rigging Point Height: Front Bumper Rigging Point height referenced to Z=0;
- Lower Cabinet Height: referenced to Z=0;
- Distance between rigging points: horizontal distance from Rear to Front Bumper Rigging Points
- Gravity Center to Front Rigging Point: horizontal distance from Gravity Center to Front Rigging Point (must be positive and less than distance between rigging points, turns red if gravity center off rigging points, turns orange if 5% to the limits)
- Gravity Center to Rear Rigging Point: horizontal distance from Gravity Center to Rear Rigging Point (must be positive and less than distance between rigging points, turns red if gravity center off rigging points, turns orange if 5% to the limits)
- Clearance from Front Rigging Point: minimum free space required ahead of Front Rigging Point
- Clearance from Rear Rigging Point: minimum free space required behind Rear Rigging Point
- Cluster Weight: total cluster weight including rigging accessories
- Weight on Front Rigging Point: must be positive and less than total Cluster Weight (turns red if gravity center off rigging points, turns orange if 5% to the limits)
- Weight on Rear Rigging Point: must be positive and less than total Cluster Weight (turns red if gravity center off rigging points, turns orange if 5% to the limits)



Mechanical Forces

FORCES	
Allowed load on bumper configuration rear point S1	57.25 kN
Applied load on bumper configuration rear point S1	6.48 kN
Allowed load on bumper configuration front point S2	57.25 kN
Applied load on bumper configuration front point S2	2.82 kN
Allowed pressure/tensile loads on T4805 rear point S1	-36.00 kN / 26.00 kN
Applied min/max loads on T4805 rear point S1	0.00 kN / 4.93 kN
Allowed pressure/tensile loads on T4805 rear point S2	-36.00 kN / 34.50 kN
Applied min/max loads on T4805 rear point S2	-0.35 kN / 0.32 kN
Allowed pressure/tensile loads on T2815 rear point S1	0.00 kN / 14.75 kN
Applied min/max loads on T2805 rear point S1	0.00 kN / 0.08 kN
Allowed pressure/tensile loads on T2815 rear point S2	-36.00 kN / 34.50 kN
Applied min/max loads on T2805 rear point S2	0.00 kN / 0.08 kN
Allowed load on Kelping chain	15.00 kN
Applied load on Kelping chain	0.00 kN
Allowed load on CD18 flying rails	1.90 kN
Applied load on CD18 flying rails	0.80 kN

- Allowed load on selected bumper rear rigging point R1: theoretical tensile force value limit
- Applied load on selected bumper rear rigging point R1: configuration applied value (turns red if outside limits)
- Allowed load on selected bumper front rigging point R2: theoretical tensile force value limit
- Applied load on selected bumper front point rigging R2: configuration applied value (turns red if outside limits)
- Allowed pressure/tensile loads on T4805 rear point S1: theoretical pressure/tensile force value limit
- Applied min/max loads on T4805 rear point S1: configuration applied value (turns red if outside limits)
- Allowed pressure/tensile loads on T4805 front point S2: theoretical pressure/tensile force value limit
- Applied min/max loads on T4805 front point S2: configuration applied value (turns red if outside limits)
- Allowed pressure/tensile loads on T2815 rear point S1: theoretical pressure/tensile force value limit
- Applied min/max loads on T2815 rear point S1: configuration applied value (turns red if outside limits)
- Allowed pressure/tensile loads on T2815 front point S2: theoretical pressure/tensile force value limit
- Applied min/max loads on T2815 front point S2: configuration applied value (turns red if outside limits)
- Allowed load on Kelping Chain: theoretical tensile force value limit
- Applied load on Kelping Chain: configuration applied value (turns red if outside limits)
- Allowed Load on CD18 flying rails: theoretical tensile force values
- Applied Load on CD18 flying rails: configuration applied values (turns red if outside limits)



Angle Sequence

- Delta: Inter Cabinets Angle Sequence
- Sum: Cumulative Angle Sequence

ANGLE SEQUENCE		
#	Delta	Sum
Bumper	-11.00	0.76
1	2.00	-1.24
2	3.15	-4.39
3	3.15	-7.54
4	3.15	-10.69
5	5.00	-15.69
6	5.00	-20.69
7	17.50	-38.19

Working Load – Safety Factor – Lifting Factor

WORKING LOAD - SAFETY FACTOR	
GEOT Cluster	
% allowed working load (safety factor 4)	19
Safety factor for 100% allowed working load	21.1
CD18 Cluster	
% allowed working load (safety factor 4)	42
Safety factor for 100% allowed working load	9.5

GeoT cluster - Percentage of Allowed Working Load

Is based on the ratio of all applied moments and forces to their limit

Is determined by the component which is the closest to its limits

Corresponds to a Safety Factor of 4 when is equal to 100%

Must not be above 100% (turns red if so)

GeoT cluster - Safety Factor for 100% of Allowed Working Load

Project configuration Safety Factor

Must not be below 4 (turns red if so)

Can be used to comply with local regulations

CD18 cluster - Percentage of Allowed Working Load

Is based on the ratio of all applied moments and forces to their limit

Is determined by the component which is the closest to its limits

Corresponds to a Safety Factor of 4 when is equal to 100%

Must not be above 100% (turns red if so)

CD18 cluster - Safety Factor for 100% of Allowed Working Load

Project configuration Safety Factor

Must not be below 4 (turns red if so)

Can be used to comply with local regulations



Caution – Warning Messages

Warning Messages for Rigging feasibility and safety.

Permanently displayed messages

CAUTION

READ USER MANUAL PRIOR TO OPERATION
CHECK LOCAL REGULATIONS ON LOUDSPEAKER RIGGING SYSTEM
ENSURE ANGLES SETTINGS ARE IDENTICALLY ON BOTH SIDES
CHECK WITHOUT WINDFORCES

Conditional messages

These messages are related to unfeasible or unsafe loads:

FRONT RIGGING POINT NOT IN TENSION LOAD
UNSAFE LOAD FOR GEOT CLUSTER
UNSAFE LOAD FOR CD18 CLUSTER
SAFETY FACTOR TOO LOW

Cluster Drawings

Drawings are displayed to show computed points and cluster setup configurations.

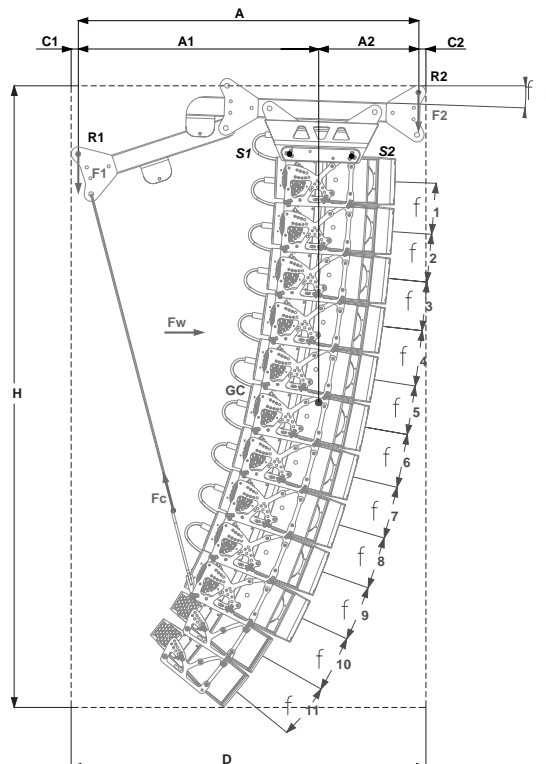

NEXO

NEXO

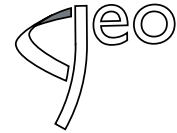

GEO D Series

D10 10° Tangent Array Module

Geo Sub Directional Sub-bass



User Manual

GEO Technology is radically new thinking

The GEO R&D Project has, to date, resulted in the following patent applications:

- The GEO Hyperboloid Reflective Wavesource™ differs radically from the megaphone-variant type horns you know and love (or hate). “Tried and true” methods will produce entirely unexpected results. HRW technology produces precise and predictable results.
- The Configurable Directivity Flange. A waveguide that allows the operator to alter its behaviour. An unprecedented NEXO development that is easy to use – once you know how and when.
- The Directivity Phase Device needs no operator input to function, but it is reassuring to know that the coupling of the midrange of the system is considered as important as the high frequencies...
- GEO’s DSP-driven Cardioid Dipolar Sub-bass devices are a new approach to controlling LF/VLF acoustic energy.

GEO is not hard to use when you understand how...

The technology behind GEO is revolutionary, but it is grounded in years of practical experience with the problems of delivering high quality professional sound to large audiences at high SPL levels. The GEO toolbox includes GEOSoft -a simple yet powerful and highly predictive design tool. The array assembly system is keyed to the design software and will easily enable you to deploy your design with great precision. The NX242 Digital TDcontroller provides driver protection and system optimization as well as DSP-driven cardioid pattern control for the GEO D10 Tangent Array Module and the GEO SUB Cardioid Dipole Sub-bass.

GEO is a high precision system

The GEO HRW™ controls acoustic energy more precisely than other multiple element waveguides. It also makes GEO less forgiving of mistakes. Whilst conventional horns never combine into a coherent array, they may deliver acceptable results even if the design and deployment of the system is less than optimal. This is not the case with GEO where careless installation produces catastrophic results.

A GEO Tangent Array is not a “line array”

GEO Technology is equally effective in designing and deploying tangent horizontal arrays or curved vertical arrays. For best results in a specific application the user needs to know how multi-speaker arrays interact with audience geometry, along with the benefits and drawbacks of curved vertical arrays and horizontal arrays.

Curved vertical tangent arrays require different design techniques

For the past 20 years, sound reinforcement professionals have worked with horizontal arrays that use conventional horns to deliver [more or less] ‘equal power to equal *angles*’. Curved vertical arrays are designed to deliver [more or less] equal power to equal *areas*’. When arrays use conventional horns, the lack of precision, overlap and interference masks errors in array design and aiming. The highly precise GEO wavesource responds accurately, consistently and predictably to the design and deployment of a curved vertical tangent array. This is why the GEO rigging system is designed to control angular splay to 0.01° precision.

GEO curved vertical tangent arrays require different operational techniques

Over the years, system designers and operators have developed a number of signal processing techniques to disguise and partly overcome the limitations of horn design. “Frequency shading,” “amplitude shading,” “system tuning,” all of these are tools of the advanced sound system operator. **NONE OF THESE TECHNIQUES ARE APPLICABLE TO GEO TANGENT ARRAYS.** Instead of enhancing the array’s performance they will severely degrade it.

Take time to learn how to get great results with GEO Technology. It is an investment that will pay off in more satisfied clients, more efficient operating procedures and more recognition for your skill as a sound system designer and operator. A comprehensive understanding of GEO theory, tangent arrays, and specific features of the GEO D Series will help you to operate your system at its full potential.

PLEASE READ CAREFULLY BEFORE PROCEEDING**BASIC PRECAUTIONS**

Do not open the speaker system or attempt to disassemble the internal parts or modify them in any way. The speaker system contains no user-serviceable parts. If it should appear to be malfunctioning or damaged, discontinue use immediately and have it inspected by qualified NEXO service personnel.

Water exposure: Do not expose the speaker system to direct rain, do not use it near water or in wet conditions. Do not place containers with liquid on speaker system as they might spill into openings. If any liquid such as water seeps into the speaker system, have it inspected by qualified NEXO personnel.

SYSTEM DEPLOYMENT SAFETY RULES

Read User Manual before deployment. Before use of enclosed speaker system, please ensure that anyone involved in system deployment understands the rigging – stacking – pole mounting safety rules as described in the speaker system User Manual. Failure to do this exposes people to potential injury or death.

Always consult qualified NEXO personnel if the device installation requires construction work and make sure to observe the following precautions:

Mounting precautions

- choose mounting hardware and an installation location that can support the weight of the speaker system;
- do not use speaker system handles for suspended installation;
- do not expose speaker system to excessive dust or vibration, or extreme cold or heat to prevent possibility of component damage;
- do not place the speaker system in an unstable position from which it might fall accidentally;
- if speaker systems uses a stand, ensure that stand specifications are adapted, and that stand height does not exceed 1.40m/55"; never move the stand while the speaker is in position.

Connection and powering precautions

- remove all connected cables before moving the speaker system;
- turn off AC power of all power amplifier units before connecting the speaker system;
- when turning on the AC power to the audio system, always turn on the power amplifier last; when turning the AC power off, always turn off the power amplifier first;
- when used in cold conditions, a gradual power ramp up should applied to the system on an 5 mn period to allow the loudspeaker components to stabilize during the very first minutes of usage.

Inspect the speaker system periodically.





SAFETY INSTRUCTIONS FOR NEXO TD CONTROLLERS



NEXO ANALOGUE PSTDCONTROLLERS, NX242 DIGITAL CONTROLLER, NXAMP4x1 AND NXAMP4x4 POWERED CONTROLLERS ARE CLASS 1 APPARATUS AND MUST BE EARTHED.

THE GREEN AND YELLOW WIRE OF THE MAINS CORD MUST ALWAYS BE CONNECTED TO AN INSTALLATION SAFETY EARTH OR GROUND. THE EARTH IS ESSENTIAL FOR PERSONAL SAFETY AS WELL AS THE CORRECT OPERATION OF THE SYSTEM, AND IS INTERNALLY CONNECTED TO ALL EXPOSED METAL SURFACES.

- Read these instructions.
- Keep these instructions.
- Heed all warnings.
- Follow all instructions.
- Do not use this apparatus near water.
- Clean only with dry cloth.
- Do not block any ventilation openings. Install in accordance with the manufacturer's instructions.
- Do not install near any heat sources such as radiators, heat registers, stoves, or other apparatus (including amplifiers) that produce heat.
- Do not defeat the safety purpose of the polarized or grounding-type plug. A polarized plug has two blades with one wider than the other. A grounding type plug has two blades and a third grounding prong. The wide blade or the third prong are provided for your safety. If the provided plug does not fit into your outlet, consult an electrician for replacement of the obsolete outlet. (US market)
- Protect the power cord from being walked on or pinched particularly at plugs, convenience receptacles, and the point where they exit from the apparatus.
- Only use attachments/accessories specified by the manufacturer.
- Unplug this apparatus during lightning storms or when unused for long periods of time.
- Refer all servicing to qualified service personnel. Servicing is required when the apparatus has been damaged in any way, such as power-supply cord or plug is damaged, liquid has been spilled or objects have fallen into the apparatus, the apparatus has been exposed to rain or moisture, does not operate normally, or has been dropped.

 <p>The lightning flash with arrowhead symbol, within an equilateral triangle is intended to alert the user to the presence of uninsulated "dangerous voltage" within the product's enclosure that may be of sufficient magnitude to constitute a risk of electric shock to persons.</p>	 <div style="border: 1px solid black; padding: 2px; display: inline-block; text-align: center;"> CAUTION <small>RISK OF ELECTRIC SHOCK DO NOT OPEN</small> </div> 	 <p>The exclamation point within an equilateral triangle is intended to alert the user to the presence of important operating and maintenance (servicing) instructions in the literature accompanying the appliance.</p>
<p>WARNING: To reduce the risk of fire or electric shock, do not expose this apparatus to rain or moisture.</p>		
<p>To avoid electrical shock, do not remove covers. Dangerous voltages exist inside. Refer all servicing to qualified personnel only.</p>		

HIGH SOUND PRESSURE LEVELS



Exposure to extremely high noise levels may cause permanent hearing loss. Individuals vary considerably in susceptibility to noise-induced hearing loss but nearly everyone will lose some hearing if exposed to sufficiently intense noise for a sufficient period of time. The U.S. Government's Occupational and Health Administration (OSHA) has specified the following permissible noise level exposures: Sound Duration Per

Day In Hours	Sound Level dBA, Slow Response
8	90
6	92
4	65
3	97
2	100
1 ½	102
1	105
½	110
¼ or less	115

According to OSHA, any exposure in excess of the above permissible limits could result in some hearing loss. Ear plugs or protectors to the ear canals or over the ears must be worn when operating this amplification system in order to prevent permanent hearing loss, if exposure is in excess of the limits as set forth above. To ensure against potentially dangerous exposure to high sound pressure levels, it is recommended that all persons exposed to equipment capable of producing high sound pressure levels such as this amplification system be protected by hearing protectors while this unit is in operation.

DISPOSAL OF OLD ELECTRICAL & ELECTRONIC EQUIPMENT



This symbol on the product or on its packaging indicates that it shall not be treated as household waste. Instead it shall be handed over to the applicable collection point for the recycling of electrical and electronic equipment. By ensuring this product is disposed of correctly, you will help prevent potential negative consequence for the environment and human health, which could otherwise be caused by inappropriate waste handling of this product. The recycling of materials will help to conserve natural resources. For more detailed information about recycling of this product, please contact your local city office, your household waste disposal service or the shop where you purchased the product.

CONTENTS

PLEASE READ CAREFULLY BEFORE PROCEEDING	3
CONTENTS.....	6
1 Introduction	8
2 GEO D General Set-up Instructions	10
2.1 <i>Speaker Wiring</i>	<i>10</i>
2.2 <i>Amplifier Selection</i>	<i>12</i>
3 NS-1 Simulation software.....	16
4 Configurable Directivity Device.....	17
4.1 <i>Installing & removing GEO's Configurable Directivity flanges</i>	<i>17</i>
4.2 <i>When & where to use Configurable Directivity flanges</i>	<i>18</i>
5 GEO D rigging procedure.....	19
5.1 <i>SAFETY FIRST</i>	<i>19</i>
5.2 <i>General Description</i>	<i>22</i>
5.3 <i>GEO D – GEO SUB Ground Stacked</i>	<i>27</i>
5.4 <i>GEO D Cluster Flying Setup (1 motor).....</i>	<i>32</i>
5.5 <i>GEO D Cluster Flying Setup (2 motors).....</i>	<i>41</i>
5.6 <i>GEO SUB – GEO D Combined Cluster Flying Setup (2 motors required).....</i>	<i>49</i>
5.7 <i>GEO SUB Cluster Flying Setup (2 motors required).....</i>	<i>58</i>
5.8 <i>Fixed installations</i>	<i>65</i>
5.9 <i>Testing and Maintenance of the system.....</i>	<i>66</i>
6 NEXO NX242 Digital Controller for GEO D and GEO SUB.....	67
6.1 <i>NX242 Proprietary Functions</i>	<i>67</i>
6.2 <i>Cardioid LF and VLF.....</i>	<i>69</i>
6.3 <i>GEO D NX242 Setups description</i>	<i>69</i>
6.4 <i>Trouble shooting</i>	<i>70</i>

7	System alignment guidelines	72
7.1	<i>GEO SUB – GEO D Cluster design</i>	72
7.2	<i>Stacked GEO SUB's and Flown GEO D's</i>	72
7.3	<i>Flown or Stacked combined GEO SUB's and GEO D's clusters</i>	73
7.4	<i>Separate GEO SUB and GEO D clusters</i>	73
7.5	<i>Driving the GEO SUB's from the AUX send</i>	73
7.6	<i>Recommended installation tools and equipment</i>	74
8	GEO D – GEO SUB Array System Check List	75
8.1	<i>Are the NX242 Digital TDcontrollers properly configured?</i>	75
8.2	<i>Are the amplifiers properly configured?</i>	75
8.3	<i>Are the amps and the NX properly connected?</i>	75
8.4	<i>Are the speakers properly connected and angled ?</i>	75
8.5	<i>Final Pre-Sound Check Check</i>	76
9	Technical Specifications	77
9.1	<i>GEO D10 Vertical Tangent Array Module</i>	77
9.2	<i>GEO SUB Directional Sub-Bass</i>	79
9.3	<i>GEO D / GEO SUB Rigging system</i>	81
9.4	<i>NX242 TDcontroller with NX-Tension Card</i>	85
10	Connection diagrams	87
10.1	<i>GEO D cluster to amplifiers and NX242 (Stereo passive mode)</i>	87
10.2	<i>GEO D cluster to amplifiers and NX242 (Mono active mode)</i>	88
10.3	<i>GEO SUB - GEO D cluster to amplifiers and NX242 (GeoD in Passive Mode)</i>	89
11	GEO D Series Parts & Accessories List	90
11.1	<i>Array Modules & Control Electronics List</i>	90
11.2	<i>Accessories List</i>	90
12	USER NOTES	93

1 INTRODUCTION

Thank you for selecting a NEXO GEO D Series Tangent Array System. This manual is intended to provide you with necessary and useful information about your GEO System, which includes the following products:

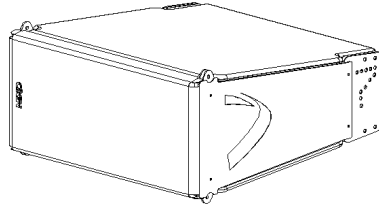

- D10 is a 10° Tangent Array Module. It comprises 2x8" (20cm) 8 Ohms LF Drivers (side firing), 1x12" (30cm) Neodymium 16 ohms LF/MF driver (front) and 1x3" voice coil, 1.4" Throat 16 Ohm HF Driver loaded by a 5° Hyperboloid Reflective Wavesource™.

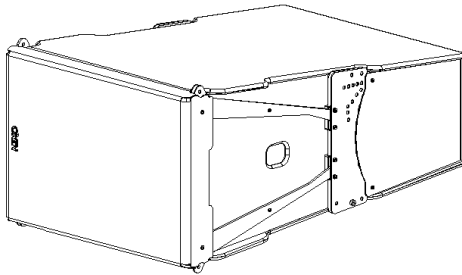

- Geo Sub is a Cardiod Dipole Sub-bass. It comprises 1x18" (46cm) Long Excursion Neodymium 8 Ohm Driver and 2x 12" (30cm) Neodymium 16 ohms LF drivers, controlled by DSP advanced proprietary algorithm, producing a 120° x 120° cardioid pattern. Can be used in conjunction with GeoD in flown clusters or in ground-stacked configuration.

- NX242 Digital TDcontroller and NXtension-ES4 provides comprehensive control of GEO D loudspeakers in multiple configurations. It allows Ethersound™ digital audio networking, as well as remote control for all units in the network.

For a complete description of this unit, please refer to the NX242 User Manual. The NX242 DSP algorithms and parameters are fixed in software and updated regularly: please consult the NEXO web site (www.NEXO.fr or www.NEXO-sa.com) for the latest software releases.

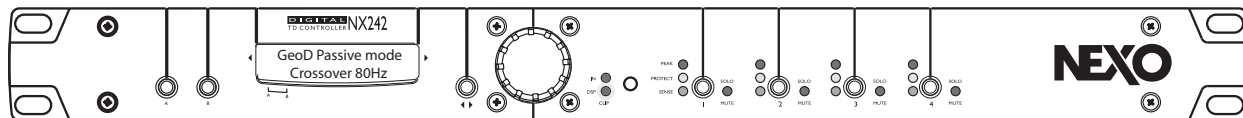

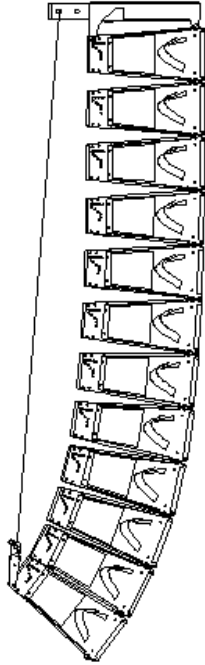

- GEO D Array Flying System. A fully integrated and accurate flying system that provides safe, flexible and simple means of flying GEO D Tangent Arrays. NOTE: GEO Tangent Arrays control the dispersion of acoustic energy with a high degree of precision. Inclinometers and laser aiming tools are essential to ensure proper audience coverage when installing a GEO Tangent Array.
- NS-1 simulation software (previously GEOSoft2) assists in the design and implementation of vertical tangent GEO arrays. Please consult the NEXO web site (www.NEXO.fr or www.NEXO-sa.com) for the latest software releases.

Please devote your time and attention to reading this manual. A comprehensive understanding of GEO theory, tangent arrays, and specific features of GEO D10 and GEO SUB and will help you to operate your system at its full potential.

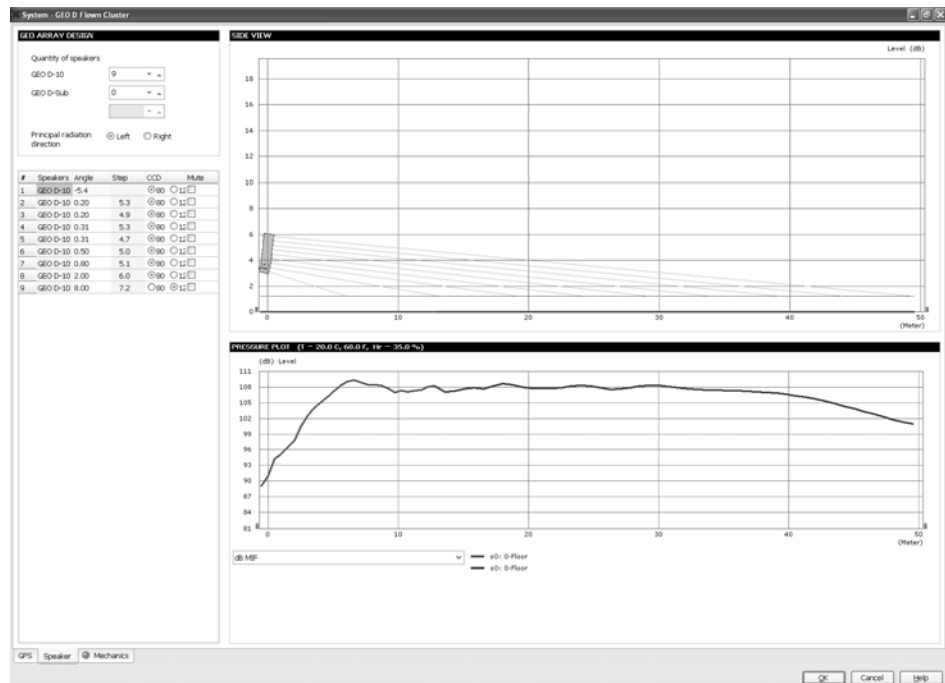

2 GEO D GENERAL SET-UP INSTRUCTIONS

2.1 Speaker Wiring

2.1.1 GEO D10 connectors

GEO D's are connected to power amplifiers via one AP6 Male Connector (GEOT-612M) on a link cable that is stowed in the rear vent port. One EP6 Female Chassis (GEOT-613F) on the back connector panel is used as output to feed the next GEO D.

A wiring diagram is printed on the connection panel located on the back of each cabinet. The EP6 / AP6 connectors are linked in parallel within the enclosures (see the Connections Diagrams section of this manual).

EP6/AP6 Pin #	1 / 2	3 / 4	5 / 6-
GEO D10 Passive Mode	Rear 8" LF - 16 Ω 1 Negative - 2 Positive	Front 12" LF/MF & 1.4" HF - 16 Ω 3 Negative - 4 Positive	Not Connected
GEO D10 Active Mode	Rear 8" LF - 16 Ω 1 Negative - 2 Positive	Front 12" LF/MF - 16 Ω 3 Negative - 4 Positive	1.4" HF - 16 Ω 5 Negative - 6 Positive

IMPORTANT

NEVER USE a male AP6 connector to feed the signal:
High voltages and currents are delivered from the amplifiers to the GEO D system.

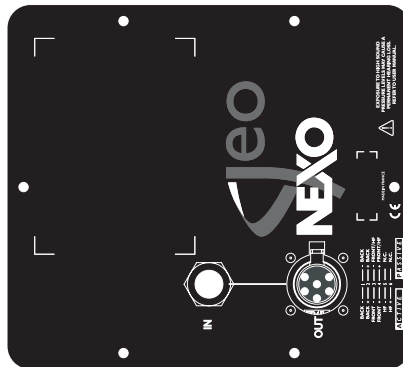

GEO D10 REAR CONNECTOR PANEL

2.1.2 Configuring GeoD10 for Passive or Active Mode

WARNING

GEO D SERIAL #0100 to #1610 PASSIVE FILTERS DO NOT OPERATE PROPERLY IN ACTIVE MODE:

IF YOUR GEO D's ARE WITHIN THESE NUMBERS, PLEASE CONTACT NEXO OR YOUR LOCAL DISTRIBUTOR SO THAT INSTRUCTIONS AND COMPONENTS ARE SENT TO YOU FOR FILTER MODIFICATION

GEO D SERIAL #0100 to #1610

Please contact NEXO or your local distributor so that instructions and components are sent to you for filter modification

GEO D Serial #1611 to above

Configuring for Passive Mode (default configuration)

- Connector A & B are link together.
- Speaker Connector is in the CN1 (passive) connector located on the PCB

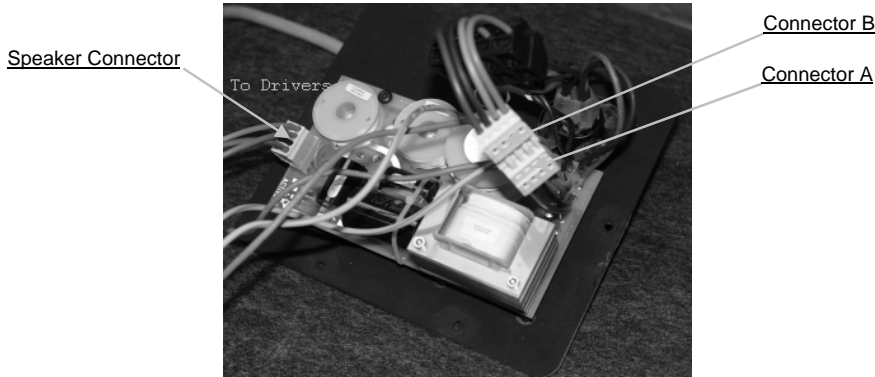

Configuring for Active Mode

- Speaker connector is directly plugged in connector B.
- Connector A is not used, PCB is bypassed.

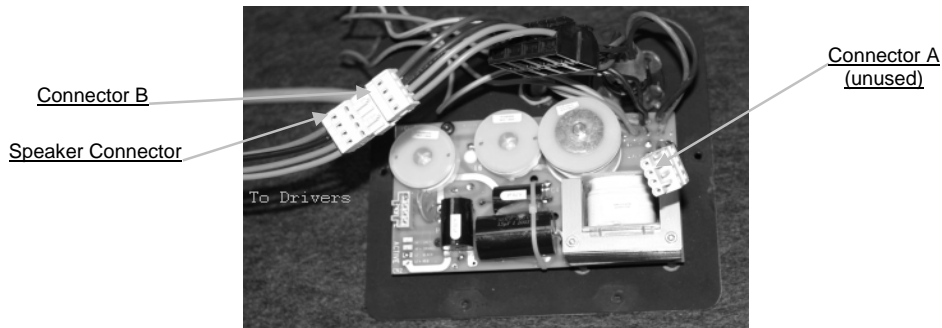

2.1.3 GEO SUB connectors

The GEO SUB's are connected to power amplifiers via NL4FC SPEAKON connectors (not supplied). A wiring diagram is printed on the connection panel located on the back of each cabinet. The in/out pins of the SPEAKON sockets are identified. The sockets are connected in parallel within the enclosures (see the Connections Diagrams section of this manual).

NL4FC #	1- / 1+-	2- / 2+
GEO SUB	Rear 12" VLF - 8 Ω 1(-) Negative - 1(+) Positive	Front 18" VLF-LF - 8 Ω 2(-) Negative - 2(+) Positive



2.1.4 Cabling

NEXO recommends the exclusive use of multi-conductor cables to connect the system: the cable kit is compatible with all the cabinets, and there is no possible confusion between LF, MF and HF sections.

Cable choice consists mainly of selecting cables of the correct sectional dimension (size) in relation to the load resistance and the cable length. Too small a cable section will increase both its serial resistance and its capacitance; this reduces the electrical power delivered to the loudspeaker and can also induce response (damping factor) variations.

For a serial resistance less or equal to 4% of the load impedance (damping factor = 25), the maximum cable length is given by:

$$L_{\max} = Z \times S \quad S \text{ in mm}^2, Z \text{ in Ohm, } L_{\max} \text{ in meters}$$

The table below indicates these values, for 3 common sizes.

Load Impedance (Ω)	2	3	4	6	8	12	16
Cable section	Maximum Length (meters)						
1,5 mm ² (AWG #14)	3	4.5	6	9	12	18	24
2,5 mm ² (AWG #12)	5	7.5	10	15	20	30	40
4 mm ² (AWG #10)	8	12	16	24	32	48	64

2.1.5 Examples:

- The GEO D10 LF section has a 16 Ohms nominal impedance, so 4x GEO D10 LF section wired in parallel will present a $16/4 = 4$ Ohm load impedance. The maximum acceptable 2x2.5 mm² (AWG #12) cable length L_{\max} for such a cluster is 10 meters.
- The GEO SUB subwoofer has a 2 x 8 Ohms nominal impedance, therefore 2 GEO SUB's wired in parallel will present a 2 x 4 Ohm load impedance. The maximum acceptable 2x4 mm² (AWG #10) cable length L_{\max} is then 16 meters.

IMPORTANT

Long speaker cables induce capacitive effects - up to hundreds of pF depending on the quality of the cable - with a low-pass effect on high frequencies. If long speaker cables must be used, ensure that they do not remain coiled while in use.

2.2 Amplifier Selection

NEXO recommends high power amplifiers in all cases. Budget constraints are the only reason to select lower power amplifiers. A lower power amplifier will not reduce the chances of driver damage due to over-exursion, and may actually increase the risk of thermal damage due to sustained clipping. If an incident occurs on an installation without protection, the fact that amplifiers only generating half their rated output power (-3dB) are used will not change anything in respect of possible damage. This is due to the fact that the RMS power handling of the weakest component in the system is always 6 to 10 dB lower than the amplifier rating.

2.2.1 GEO D10 recommended amplification

GEO D10 is rated for very high power handling and has a 16 Ohms nominal impedance per channel (Passive 2 ways or Active 3 ways).

These high impedance values allow connection of 3 to 6 cabinets in parallel for each amplifier channel.

Nexo recommends amplifiers in agreement with table below:

Recommended Amplifier#	Channel 1 LF Rear	Channel 2 LF/MF Front + HF in Passive Mode	Channel 3 HF in Active Mode
GEO D10 Passive Mode 3 in parallel (5.3 Ohms load)	1750 to 3100 W / 4 Ohms	1750 to 3100 W / 4 Ohms	
GEO D10 Active Mode 3 in parallel (5.3 Ohms load)	1750 to 3100 W / 4 Ohms	1750 to 3100 W / 4 Ohms	875to 1550 W / 4 Ohms
GEO D10 Passive Mode 4 in parallel (4 Ohms load)	2000 to 3600 W / 4 Ohms	2000 W to 3600 W / 4 Ohms	-
GEO D10 Active Mode 4 in parallel (4 Ohms load)	2000 to 3600 W / 4 Ohms	2000 to 3600 W / 4 Ohms	1000 to 1800 W / 4 Ohms
GEO D10 Passive Mode 6 in parallel (2.7 Ohms load)	3300 to 6000 W / 2 Ohms	3300 to 6000 W / 2 Ohms	
GEO D10 Active Mode 6 in parallel (2.7 Ohms load)	3300 to 6000 W / 2 Ohms	3300 to 6000 W / 2 Ohms	1650 to 3000 W / 2 Ohms

2.2.2 GEO SUB recommended amplification

The GEO SUB requires two amplifier channels delivering separately processed signals to produce its directional pattern.

Recommended Amplifier#	Channel 1 VLF Rear	Channel 2 VLF-LF Front
GEO SUB Single (8 Ohms load)	1000 to 2000 W / 8 Ohms	1000 to 2000 W / 8 Ohms
GEO SUB 2 in parallel (4 Ohms load)	2000 to 4000 W / 4 Ohms	2000 to 4000 W / 4 Ohms

2.2.3 Current rating

It is very important that the amplifier behaves correctly under low load conditions. A speaker system is reactive by nature: on transient signals like music it will require four to ten times more instantaneous current than its nominal impedance would indicate. Amplifiers are generally specified by continuous RMS power into resistive loads, however the only useful information about current capacity is the specification into a 2 Ohm load. It is possible to perform an amplifier listening test by loading the amps with twice the number of cabinets considered for the application (2 speakers per channel instead of one, 4 instead of 2) and running the amps up to the onset of clipping. If the signal does not noticeably deteriorate, the amplifier is well adapted (overheating after approximately ten minutes is normal but thermal protection must not operate too quickly after starting this test).

2.2.4 Amplifier settings

Gain value

Gain is the key to correct alignment of the system. It is especially important to know the gain of all amplifiers used in your set-up. The tolerance should be about ± 0.5 dB. In practice this can be difficult to achieve because:

- Some amplifier brands have an identical input sensitivity for models of different power rating (this infers a different voltage gain for each model). For example, a range of amplifiers with different power outputs, all having a published input sensitivity of 775mV/0dBm or 1.55V/+6dBm, will have a wide range of actual gains – the higher the power, the greater the gain.
- Various other brands may offer constant gain but only within a given product range, for example they may fit fixed input sensitivity only on their semi-professional amps.
- Even if a manufacturer applies the constant gain rule to all models, the value selected will not necessarily be the same as that chosen by other manufacturers.
- Some products can exhibit manufacturing tolerances for the same model of ± 1 dB or more. Some amplifiers may have been modified, possibly without any label indicating the new values. Others may have gain switches fitted internally where it is impossible for the user to verify the actual setting without opening the amplifier casing.
- In cases where you don't know the gain of your amplifier (or want to check it) please follow this procedure:
 - 1) Unplug any loudspeakers from the amplifier outputs
 - 2) With a signal generator, feed a sine wave at 1000Hz at a known voltage (say 0.5V) to the input of the amplifier under test
 - 3) Measure the voltage at the output of the amplifier
 - 4) Calculate the gain using the formula $\text{Gain} = 20 * \text{LOG}_{10}(\text{Vout}/\text{Vin})$.

Some examples:

Vin / Gain	20dB	26dB	32dB	37dB (1.4V sensitivity / 1350Wrms)
0.1 V	1 V	2 V	4 V	7.1 V
0.5 V	5 V	10 V	20 V	35.4 V
1 V	10 V	20 V	40 V	70.8 V

Remember that constant sensitivity settings will give a different gain value when the amplifier power is different.

NEXO recommends low gain amplifiers: +26dB is recommended, as it is at the same time adequately low and quite common amongst amplifier manufacturers. This gain setting improves signal to noise ratio and allows all preceding electronic equipment, including the NX242 TDcontroller, to operate at optimum level. Remember that using a high gain amplifier will raise the noise floor proportionally.

Operating Mode

Most two channel amplifiers available on the pro-audio market have the following operating modes:

- Stereo: two fully independent channels deliver identical power into identical loads
NEXO recommends Stereo Mode for all amplifier channels feeding GEO D10's and GEO SUB's.

- **Bridge-Mono:** the second signal channel processes the same input as the first channel, but with reversed phase. The (single) load is connected between the two positive channel outputs using a suitable connection. While the total output of the amplifier remains the same, the available output voltage, the minimum impedance that can be connected and the voltage gain are doubled as compared with stereo operation. Typically, only channel 1 input is active. Positive and negative output connections vary depending on amplifier manufacturers.

NEXO does not recommend Bridge Mono Mode unless amplifier power is clearly not sufficient.

IMPORTANT

When in Bridge-Mono mode, check your amplifier user manual for proper connection of outputs 1(+) and (2+) in relation to input phase.

- **Parallel-mono:** the output terminals of the two channels are configured in parallel using an internal relay. The (single) load is connected either to the output of channel 1 or to that of channel 2 (as if in stereo). While the total output of the amplifier remains the same the output voltage level is also the same as in stereo mode. The minimum impedance that can be connected is reduced by half due to the fact that current capability is doubled. Typically, only channel 1 input is active.

NEXO does not recommend Parallel-Mono Mode for any GEO D10 or GEO SUB amplification.

Warning on amplifiers signal processing features

Some high-end amplifiers may include signal processing functions similar to those found in the NX242 TDcontroller ("loudspeaker offset integration", "limiter", "compressor," etc.). Moreover, when this processing is digital, computation latency time can introduce a few milliseconds delay from input to output. These functions are not adapted to specific system requirements and may interfere with the complex protection algorithms used in the NX242.

NEXO do not advise using other protection systems in conjunction with the NX242 and they should be disabled.

IMPORTANT

For proper system protection, no latency time or non-linear devices should be introduced between the output of the NX242 TDcontroller and the input of loudspeakers through use of DSP modules such as internal amplifier signal processing.

2.2.5 Example

For a 6 GEO D10 and 2 GEO SUB cluster, and considering an amplifier model which is capable of delivering 2 x 3300W into 2 Ohms or 2 x 2300W into 4 Ohms, NEXO recommends the following quantities and settings:

- **GeoD Passive Mode:**
2 amplifiers, 3 x GEO D10 per amplifier (1 channel LF rear, 1 channel LF/MF/HF Front), mode switch in Stereo position, Gain switch in 26 dB gain position, all dynamic or filter processing switches off.
- **GEO SUB :**
1 amplifier, 2 x GEO SUB per amplifier (1 channel VLF rear, 1 channel VLF/LF Front), mode switch in Stereo position, Gain switch in 26 dB gain position, all dynamic or filter processing switches off.

Which gives a total of 3 identical amplifiers for such a cluster.

3 NS-1 SIMULATION SOFTWARE

NS-1 software is a R&D simulation tool derived application. It processes measured speaker data with complex mathematical algorithms to assist the user in optimizing system design. Due to the complexity of the interaction of multiple cabinets, it is simply not possible to reliably design curved vertical arrays without using the processing power of a computer to predict the optimum array structure for a given audience geometry. The design logic is far more complex than looking at a section drawing of the venue, measuring the overall angle needed to cover the audience from the cluster location, and dividing by 10 degrees to determine the required amount number of GEO D10 & GEO SUB cabinets.

NS-1 is an easy to use tool that allows to shape the energy leaving the cluster to fit the audience. It predicts pressure levels radiated from the system to ensure enough cabinets are provided for the application, as well as mechanical constraints for safe flown systems.

In addition, it provides mechanical information for all clusters in agreement with Structural Analysis Reports (available in the Help section): dimensions, weight, gravity center position, forces, moments, working load and safety factor.

Geo D10 and GEO SUB Structural Analysis Reports have been validated by German Certification Organization RWTUV systems GmbH.

NS-1 installation package includes all NEXO User Manuals, Structural Analysis Reports and Certificates PDF files (which can be found in the last section of User Manuals).

NS-1 is a freeware available for all Nexo users. Please contact your local distributor for licensing procedure.

IMPORTANT

Never install a GEO D / GEO SUB cluster without checking its acoustical performances and mechanical safety in NS-1 prior to installation.

Any question or bug report please contact technical@nexo.fr

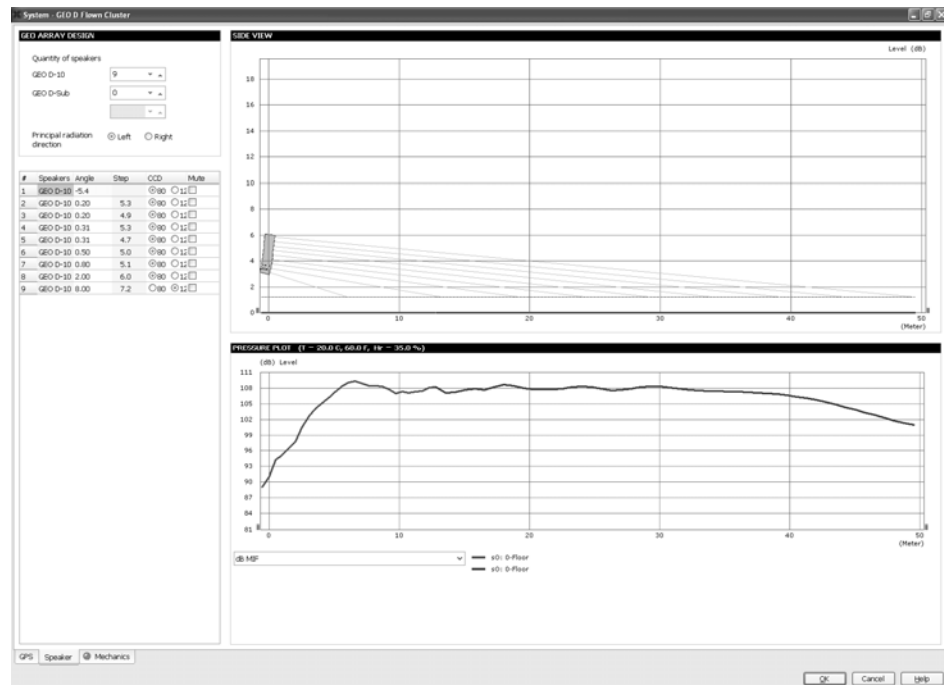

4 CONFIGURABLE DIRECTIVITY DEVICE

The GEO Wavesource controls dispersion of acoustic energy using an hyperboloid acoustical reflector in the “coupling plane” (the vertical plane of a curved vertical tangent array) and a diffraction slot in the “non-coupling plane” (the horizontal plane of a curved vertical tangent array). The patented Configurable Directivity Device consists of bolt-on flanges that alter the diffraction slot’s exit flare rate.

4.1 Installing & removing GEO’s Configurable Directivity flanges

GEO D10 are shipped in the 80° dispersion configuration, with the 120° flanges in a separate bag.

To change dispersion in the non-coupling plane to 120°:

- remove the front grill (drawings below);
- remove the three TORX (head 25) screws per flange on each side of the GEO Waveguide (drawings below);
- install the 120° flanges with the six TORX screws
- re-install the grid, being carefull that the NEXO logo must be on the GEO Waveguide side.

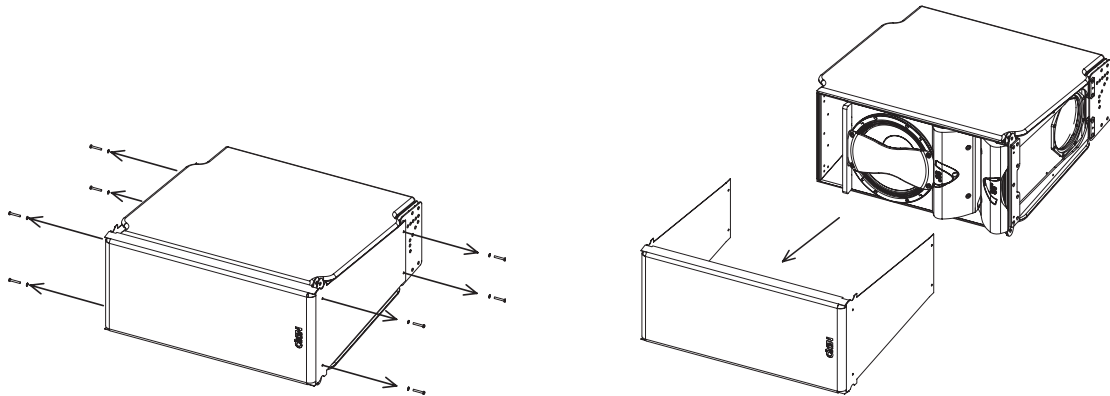

REMOVING THE GRILL

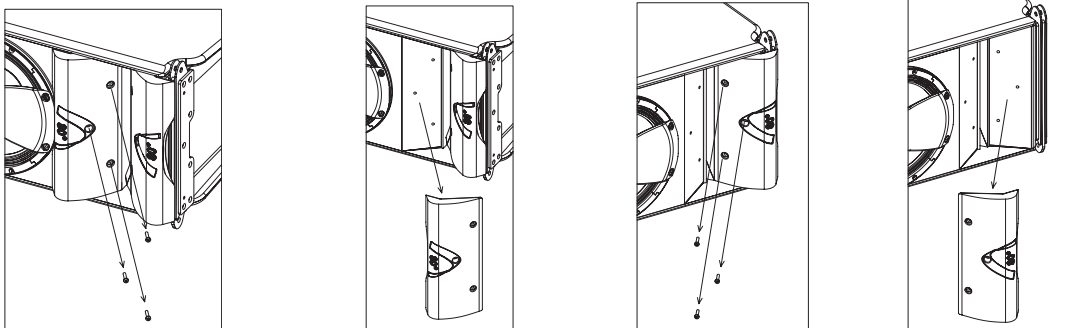

REMOVING THE FLANGES

4.2 When & where to use Configurable Directivity flanges

The diagrams show audience area coverage for a stereo system. While the GEO cluster will deliver even SPL from the front to the rear of this audience area, there are “holes” near the front in the centre and at the outside edges. We cannot fill the outside coverage gaps without enlarging the centre gap, and vice versa (left figure below).

If 120° Configurable Directivity Devices are installed at the bottom cabinet of the clusters, coverage will look more like the pattern in right figure below.

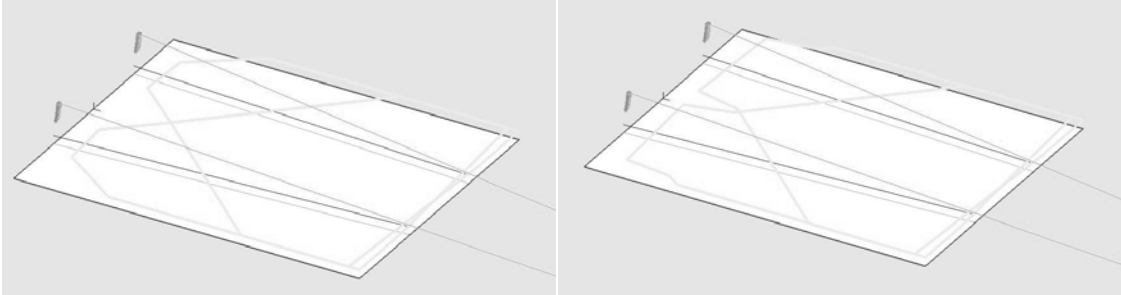

-6dB coverage, all GEO D10's in 80° configuration

-6dB coverage, bottom GEO D10's in 120° configuration

In curved vertical arrays, the 120° Configurable Directivity Device can be used:

- On the bottom row of curved vertical arrays, to fill in coverage gaps in the front rows.
- On all rows of curved vertical arrays, in cases where 120° of horizontal coverage is preferred to 80°.

Figure below shows isocontour coverage for 80° and 120° configurations.

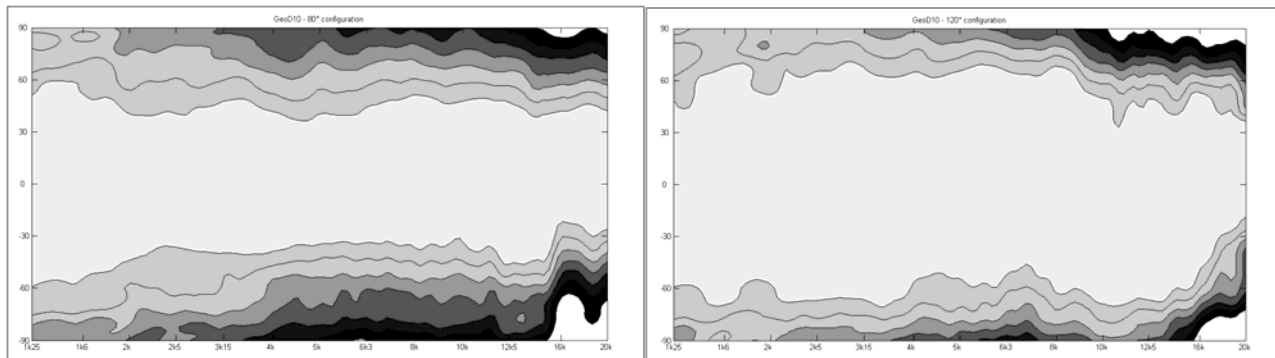

FIGURE 3: 80° AND 120° CONFIGURATIONS ISOCONTOUR COVERAGE

5 GEO D RIGGING PROCEDURE

Before proceeding with assembly of GEO D arrays, please ensure that the components are present and undamaged. A component list is appended to this manual. In the event of any shortage, please contact your supplier.

For maximum efficiency the GEO D rigging system requires three experienced persons for set-up: typically one motor hoist operator, and one GEO D operator per side of the array. Good synchronisation and crosscheck between the operators are key elements for a reliable and safe set-up.

5.1 SAFETY FIRST

GEO D / GEO SUB Rigging System structural computations and related documents are available in Geosoft2 or at Nexo (info@nexo.fr) upon request.

We include this section to remind you of safe practice when flying the GEO D / GEO SUB system. Please read it carefully. However, user must always apply his or her knowledge, experience and common sense. If in any doubt, seek advice from your supplier or NEXO agent.

This manual offers guidance only for GEO D / GEO SUB loudspeaker systems. References in this manual to other rigging equipment such as motor hoists, steels, shackles etc. are made to clarify the description of GEO D / GEO SUB procedures. The user must ensure that operators are properly trained by other agencies in the use of these items.

The GEO D / GEO SUB Rigging System has been optimised for the deployment of curved vertical tangent arrays of GEO D / GEO SUB loudspeakers. Vertical angle adjustment between cabinets has been limited to specific settings to ensure correct acoustic coupling.

The GEO D / GEO SUB Rigging System is a professional precision tool set, and should be handled with extreme care. Only persons who are fully conversant with the operation of the GEO D / GEO SUB Rigging System and provided with suitable safety equipment should deploy GEO Arrays. Misuse of the GEO D / GEO SUB Rigging System could lead to dangerous consequences.

Used and maintained correctly, the GEO D / GEO SUB Rigging System will give many years of reliable service in portable systems. Please take the time to read and understand this manual. Always use GEOSoft2 to determine the optimum angle settings for a particular venue, hang point and curved vertical GEO D / GEO SUB. Applied forces and moments are strongly cabinet quantity and angle configuration dependent. Cluster configuration must be implemented and validated in Geosoft2 prior to installation.

5.1.1 Flown Systems Safety

- Always inspect all the rigging components and cabinets for damage before assembly. Pay special attention to the lifting points, and safety clips. If you suspect that any of the components are damaged or defective, DO NOT USE THE AFFECTED PARTS. Contact your supplier for replacements.
- Read this manual carefully. Also be familiar with the manuals and safe working procedures for any ancillary equipment that will be used with the GEO D / GEO SUB Rigging System.
- Applied forces and moments are strongly cabinet quantity and angle configuration dependent. Cluster configuration must be implemented and validated in Geosoft2 prior to installation.
- Ensure that all local and National regulations regarding the safety and operation of flying equipment are understood and adhered to. Information on these regulations can usually be obtained from Local Government Offices.
- When deploying a GEO D / GEO SUB system always wear protective headwear, footwear and eye protection.
- Do not allow inexperienced persons to handle a GEO D / GEO SUB system. Installation personnel should be trained in loudspeaker flying techniques and should be fully conversant with this manual.

- Ensure that motor hoists, hoist control systems and ancillary rigging components are currently certified as safe and that they pass a visual inspection prior to use.
- Ensure that public and personnel are not allowed to pass beneath the system during the installation process. The work area should be isolated from public access.
- Never leave the system unattended during the installation process.
- Do not place any object, no matter how small or light, on top of the system during the installation procedure. The object may fall when the system is flown and is likely to cause injury.
- Secondary safety steels must be installed once the system has been flown to the operating height. Secondary steels must be fitted irrespective of requirements of the local safety standards applicable to the territory.
- Ensure that the system is secure and prevented from pivoting around the motor hoist.
- Avoid any form of excessive dynamic loading to the assembly (structural computations on GEO D / GEO SUB Rigging System are based on a 1/1.2 factor for hoist or motor acceleration).
- NEVER attach any item to the GEO D / GEO SUB system other than the GEO D / GEO SUB accessories.
- When flying outdoor systems ensure that the system is not exposed to excessive wind or snow loads and is protected from rainfall.
- The GEO D / GEO SUB Rigging System requires regular inspection and testing by a competent test centre. NEXO recommend that the system is load tested and certified annually or more frequently if local regulations require.
- When de-rigging the system ensure that the same duty of care is given to the procedure as for the installation. Pack GEO D / GEO SUB components carefully to prevent damage in transit.

5.1.2 Ground Stacking Safety

Statistically, many more injuries occur due to unstable ground stacked PA systems than those associated with flown systems. There are several reasons for this fact, however the message is clear:

- Always survey the supporting structure upon which a ground stack is to be built. Always look beneath PA wings to inspect the deck support and if necessary ask for the stage scrims and dressings be removed to allow access.
- If the stage surface slopes, as it does in some theatres, ensure that the system is prevented from sliding forwards due to vibration. This may require the fitting of timber battens to the stage floor.
- For outdoor systems ensure that that the system is protected from wind forces which might cause the ground stack to become unstable. Wind forces can be huge, especially upon large systems, and should never be underestimated. Observe meteorological forecasts, calculate the “worst case” effect upon the system prior to erection and ensure that the system is secured appropriately.
- Take care when stacking cabinets. Always employ safe lifting procedures and never attempt to build stacks without sufficient personnel and equipment.
- Never allow anyone, whether operators, artists or members of the public to climb onto a ground stacked PA system. Anyone who needs to climb over 2m (6 ft) high should be fitted with suitable safety equipment including a clip-on harness. Please refer to local Health and Safety legislation in your territory. Your dealer can help with advice on access to this information.
- Apply the same attention to all safety matters when de-stacking systems.
- Be aware that safety procedures are as important in the truck and in the warehouse as they are at the venue.

5.1.3 Contacts

Correct training is fundamental to safe practise when working with loudspeakers flying systems. NEXO recommend that users contact local industry associations for information on specialist course.

Information for International training agencies can be obtained by contacting either:

The Production Services Association
(PSA),
School Passage,
Kingston-upon-Thames,
KT1 SDU Surrey,
ENGLAND
Telephone: +44 (0) 181 392 0180

Rigstar Training and Testing Center
82 Industrial Dr. Unit 4
Northampton, Massachusetts 01060 U.S.A.
Phone: 413-585-9869 -- Fax: 413-585-9872
school@rigstar.com

ESTA
Entertainment Services & Technology Association
875 Sixth Avenue, Suite 1005
NEW YORK, NY 10001 USA
Phone: 212-244-1505 – Fax: 212-244-1502
info@esta.org - www.esta.org

5.2 General Description

5.2.1 GEO D10 and GEO SUB

Each GEO D and GEO SUB Array Module includes an individual rigging system, which is mounted at the NEXO factory.

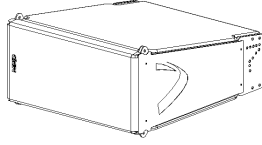

GEO D10 ARRAY MODULE

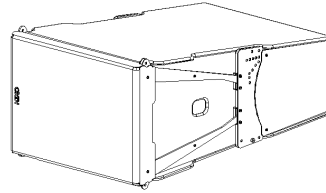

GEO SUB ARRAY MODULE

GEO D10 and GEO SUB angle sequences are identical and follow logarithmic scales. Angle setting values are:

- Bumper to first cabinet (GEO D10 or GEO SUB): 0°
- Cabinet to cabinet (GEO D10 or GEO SUB): 0.20° - 0.315° - 0.50° - 0.80° - 1.25° - 2.0° - 3.15° - 5.0° - 6.3° - 8.0° - 10°

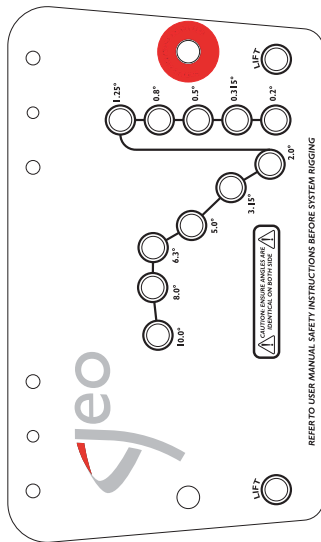

GEO D10 RIGGING PLATE

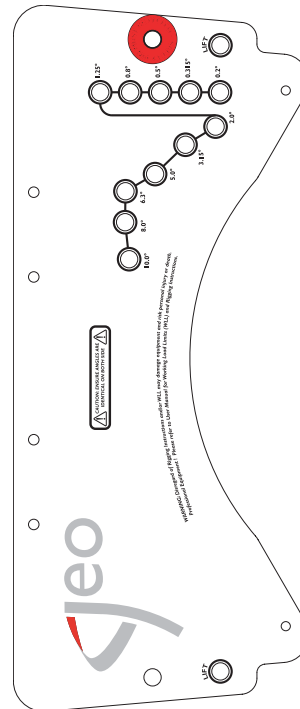

GEO SUB RIGGING PLATE

5.2.2 Rigging Accessories

Rigging Accessories are:

- Bumper (GEOD-BUMPER)
- Short Extension Bar (GEOD-EXBAR1)
- Compression Wheel for Short Extension Bar EXBAR1 (GEOD-ORP)
- Two legs Bridle (GEO-BRIDLE)
- Long Extension Bar (GEOD-EXBAR2)
- Bottom Extension Bar (GEOD-EXBAR3)
- Front Extension Bar (GEOD-EXBAR4)
- Bottom Bumper (GEOD-BTBUMPER)
- Chain Lever Hoists (LEVA0750 or LEVA1500)
- Chain Bag (CHBAG)
- Push-Pins (BLGEOD)
- Shoulder Bolts and Nuts (GEOD-BNFIX)
- Bumper Stands stacking kit (GEOD-BUDP)

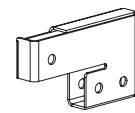

GEOD-EXBAR4

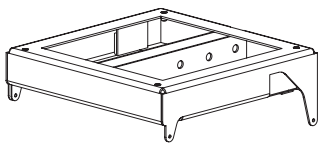

GEOD-BUMPER

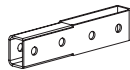

GEOD-EXBAR1



GEOD-ORP

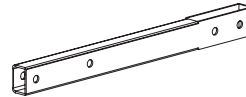

GEOD-EXBAR2

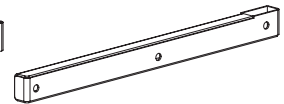

GEOD-EXBAR3

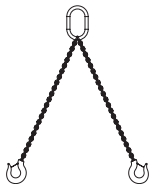

GEO BRIDLE



GEOD-BTBUMPER



GEOD-LEVA750 & LEVA1500

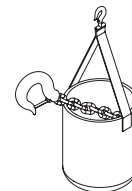

CHBAG

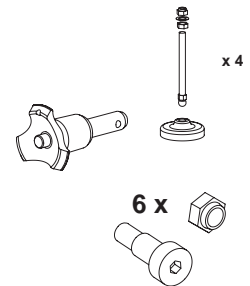

BLGEOD -GEOD-BNFIX
GEOD-BUDP

IMPORTANT

All GEOD / GEO SUB Rigging Components are specifically rated in agreement with structural computations.

Never use other accessories - including push-pins - when assembling GEO D / GEO SUB clusters than the ones provided by NEXO: NEXO will decline responsibility over the entire GEOD / GEO SUB rigging system if any component is purchased from different supplier.

5.2.3 Configurations and operating mode

General Principle

GEO D10 / GEO SUB rigging system operates in compression mode: pull-back force applied between the extreme bottom cabinet and the top bumper set angles between cabinets. When the array is lifted into position all cabinets are at 0° (1) and it is only when the pull-up force is applied that the correct angles are obtained (2). Bumper angle is then set by adjusting front and rear motors (3).

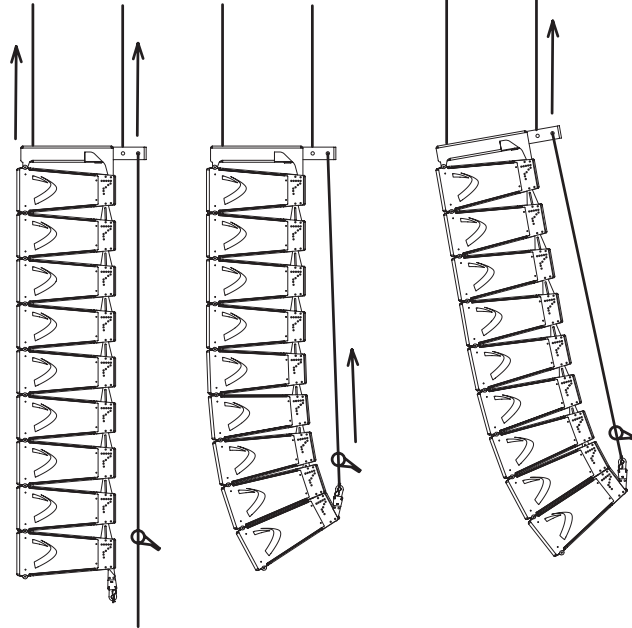

(1) LIFTING CLUSTER VERTICALLY

(2) APPLYING COMPRESSION

(3) ADJUSTING BUMPER ANGLE

In case GeoD10 cluster is flown from one rigging point (8 GEO D maximum, no GEO SUB allowed), array is lifted with all cabinets at 0° . Pull-back force and bumper angle are then set with the Chain Lever Hoist LEVA750. Please refer to sections below for detailed description.

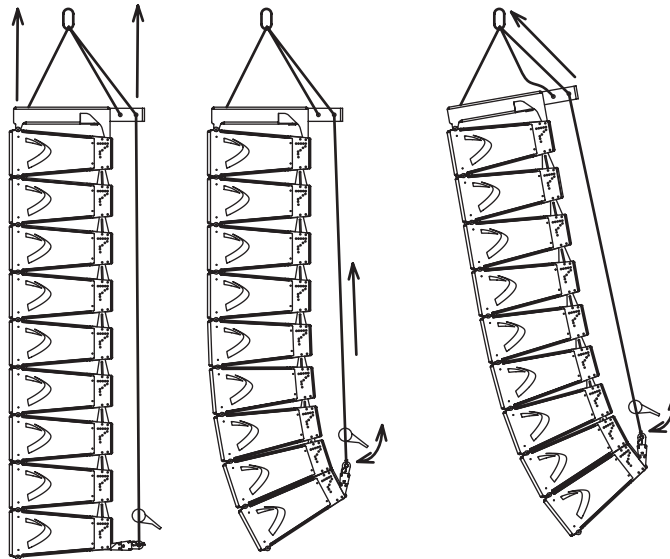

(1) LIFTING CLUSTER VERTICALLY

(2) APPLYING COMPRESSION

(3) ADJUSTING BUMPER ANGLE

Described Cases

Sections below describe GEO D10 and GEO SUB clusters rigging procedures for the following cases:

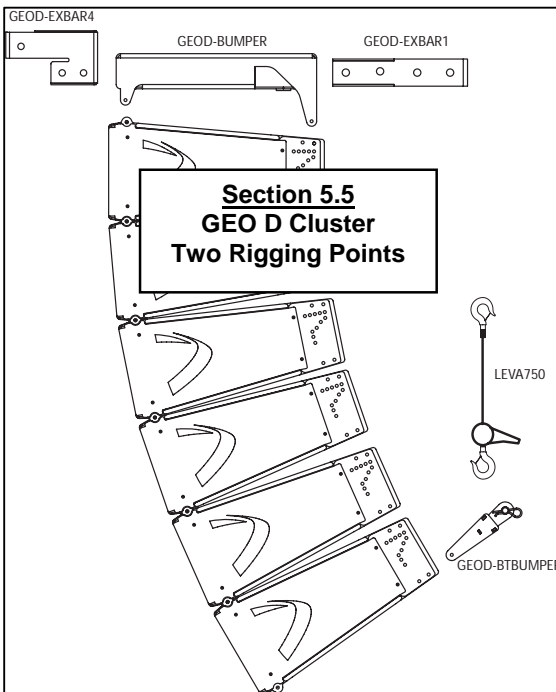
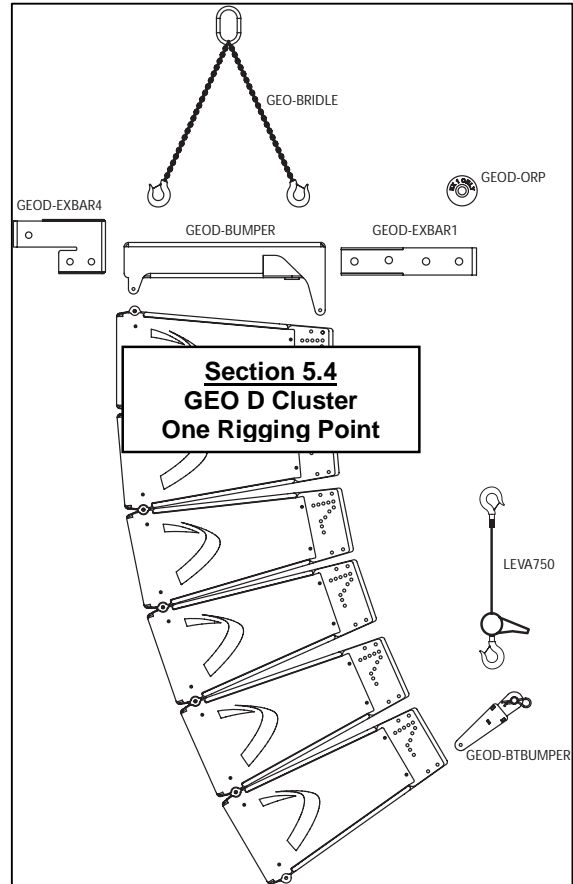
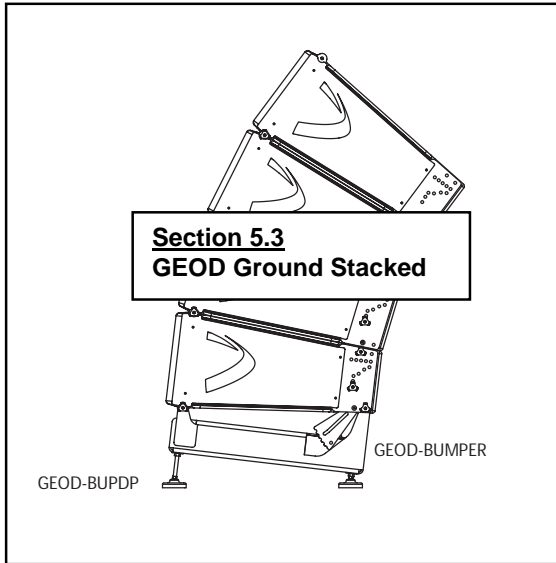

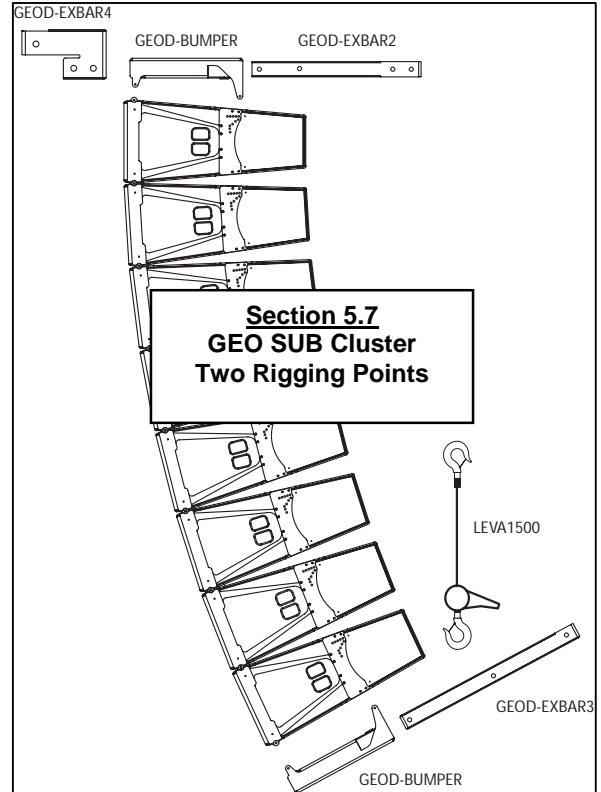
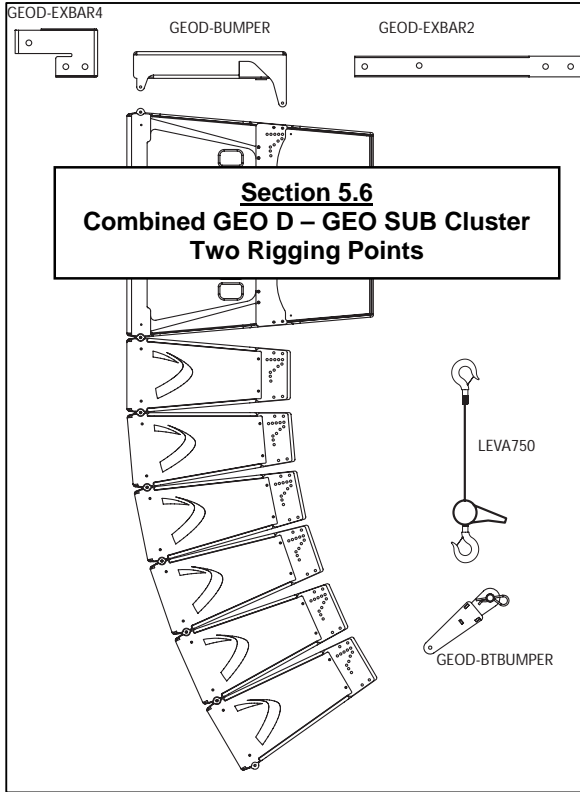

5.3 **GEO D – GEO SUB Ground Stacked**

Stacking a GEO D10 cluster requires the following accessories:

- 1 x GEO D Main Bumper (GEOD-BUMPER)
- 1 x GEO D Bumper Stands kit (GEOD-BUDP)
- 6 x GEOD push-pins per stacked GEO D10 or GEO SUB (BLGEOD)
- or 1 x GEOD shoulder bolts and nuts kit for fixed installations per stacked GEO D (GEOD-BNFX)

IMPORTANT

Ensure platform (ground, riser...) is solid enough to support stacked cluster weight (distributed on four points), and perfectly horizontal.

5.3.1 Allowed stacked configurations

IMPORTANT

Allowed Stacked Configurations are:

- 4 GEO D maximum
- or 1 GEO SUB max (bottom) + 3 GEOD max (top)
- or 2 GEO SUB

Bumper angle must never exceed +/- 6.5°

5.3.2 Installing Bumper Stands on Bumper

- Install bumper stands and nuts according to drawing below.

IMPORTANT

Make sure nuts are properly positioned on both sides of the bumper. These are mandatory for system safety

- Adjust length of each stand so that desired bumper angle is achieved (bumper side edge angle in relation to horizontal); ensure that bumper front edge is perfectly horizontal;
- Secure nuts.

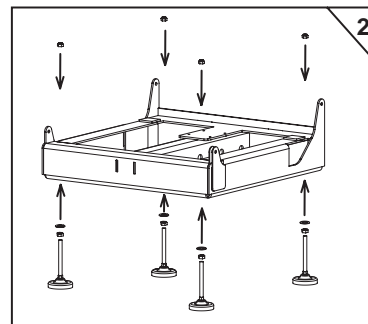
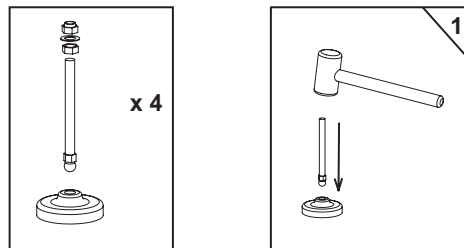

INSTALLING BUMPER STANDS

5.3.3 Bumper to first GEO D10 assembly

IMPORTANT

GEO D10 can be stacked "Left" or "Right" :

- "Left" means Nexo logo on front grid is left as seen from front;
- "Right" means Nexo logo on front grid is right as seen from front.

GEO D10 can be connected to bumper "Left" or "Right" by simply flipping the cabinets upside down: do not reverse rigging plates

Whenever possible, NEXO recommends symmetrical designs (preferably NEXO logo inwards in stereo configurations)

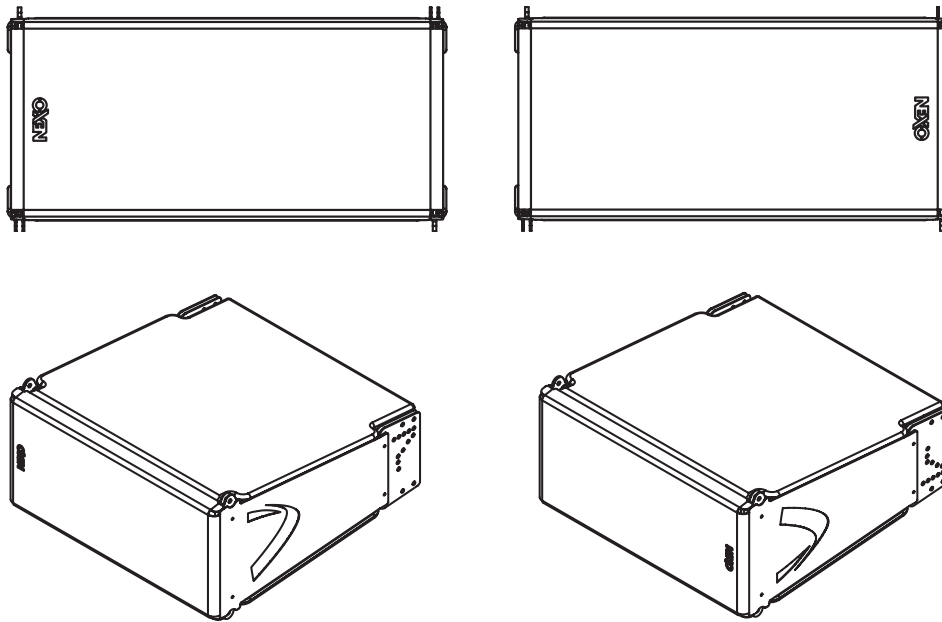

"LEFT" CONFIGURATION

"RIGHT" CONFIGURATION

4 push-pins (BLGEOD, 10mm diameter x 20 mm length) connect the bottom GEO D10 to the bumper.

- Position the first GEO D10 on bumper;
- Link the GEO D10 to the bumper assembly using the four 10mm x 20mm push-pins; front bumper connects at GEO D10 front articulation point, rear bumper connects at "LIFT" GEO D10 rigging plates holes;
- Check that all push-pins are in their locked position.

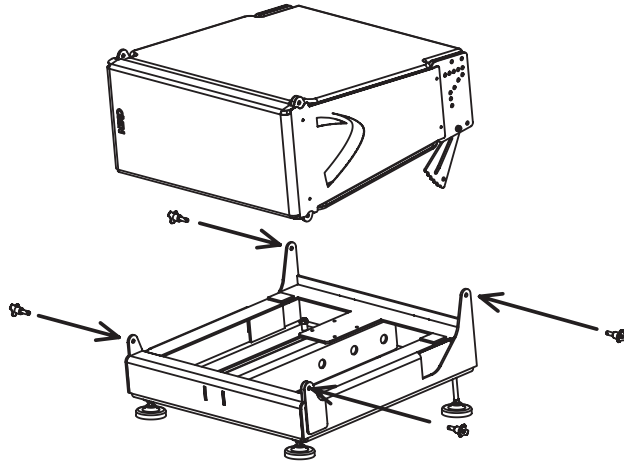

BUMPER TO FIRST GEO D ASSEMBLY

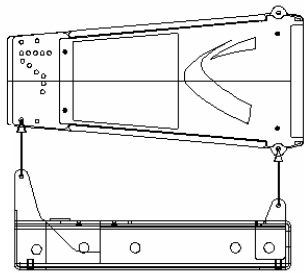

"LEFT" CONFIGURATION

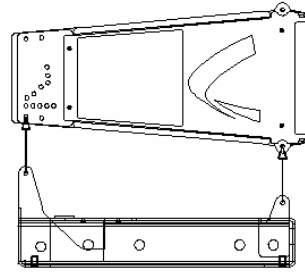

"RIGHT" CONFIGURATION

5.3.4 First to second GEO D 10

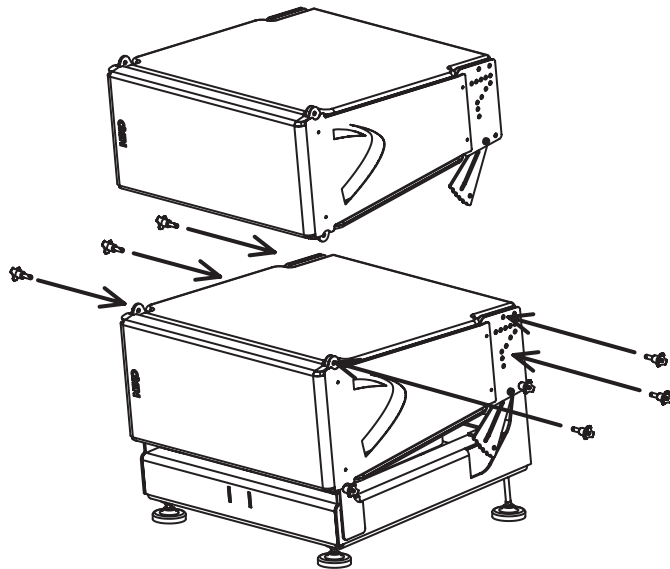

FIRST TO SECOND GEO D10

4 push-pins (BLGEOD, 10mm diameter x 20 mm length) connect first to second GEO D10, 2 additional push pins-are required for angle adjustment.

- Lift and position the next GEO D10 above the assembly, with NEXO logo on the same side than the lower cabinet.
- Lower top GEO D10 carefully until the first and second GEO D10 side rigging plates locate. Use front grid, rear vent ports or handle to guide the assembly. The rigging plates have been designed to locate against each other and so align the holes correctly.
- Connect the upper GEO D link bar to the lower GEO D rigging plate (or lower link bar to upper rigging plate for “Right” configuration) by inserting one 10mm x 20 mm push-pin in the “SAFETY PIN MUST BE FITTED” hole on each side (see figure below).

IMPORTANT

The push-pins for “SAFETY PIN MUST BE FITTED” holes must always be inserted first and stay in position permanently. NEVER REMOVE THEM ONCE CABINETS ARE STACKED.

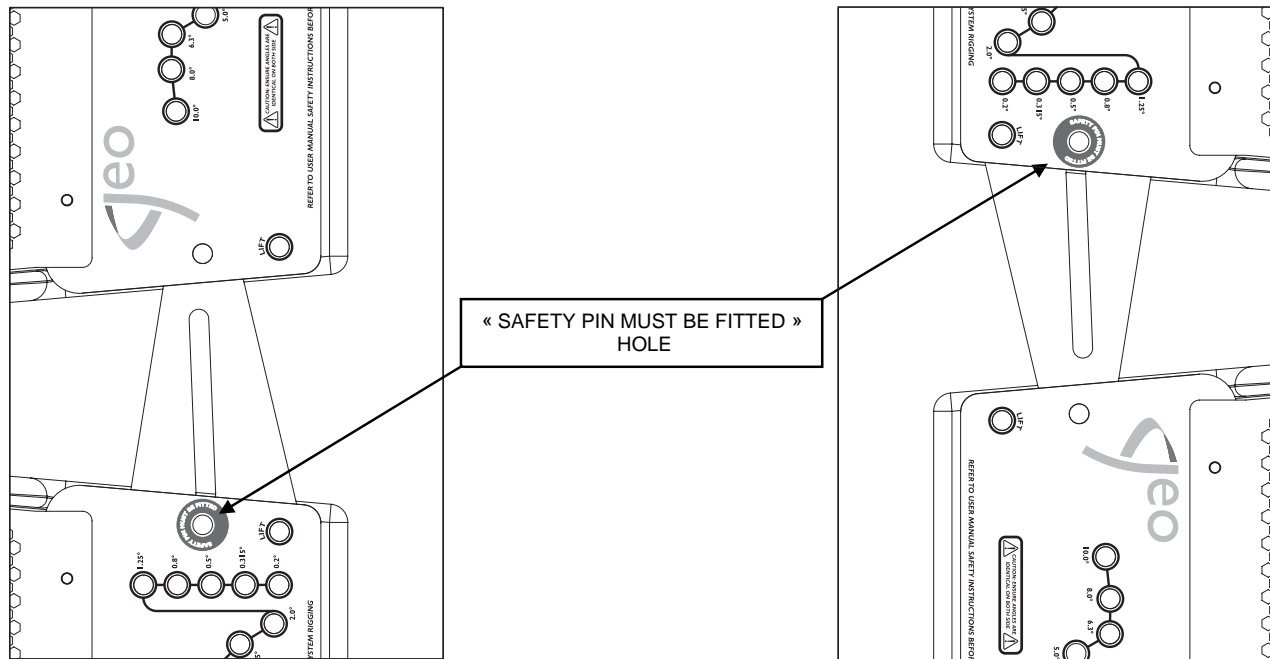

- Insert two additional 10mm x 20mm push-pins in the front holes (see figure above).
- Lift Cabinet to release weight from linking bars and insert 1 additional push-pin per side to the required angle;
- Check that all 6 push-pins are locked.

IMPORTANT

Ensure angle settings are identical on both sides of the cabinet.

5.3.5 Subsequent GEO D10's

- Repeat the above section steps, until all GEO D10's are in place.

IMPORTANT

DO NOT attempt to make any changes to the angle adjustments without releasing weight on the linking bars.

5.3.6 Ground Stacking GEO SUB with Geo D10's

Proceed exactly as above, bottom cabinet must always be a GEO SUB.

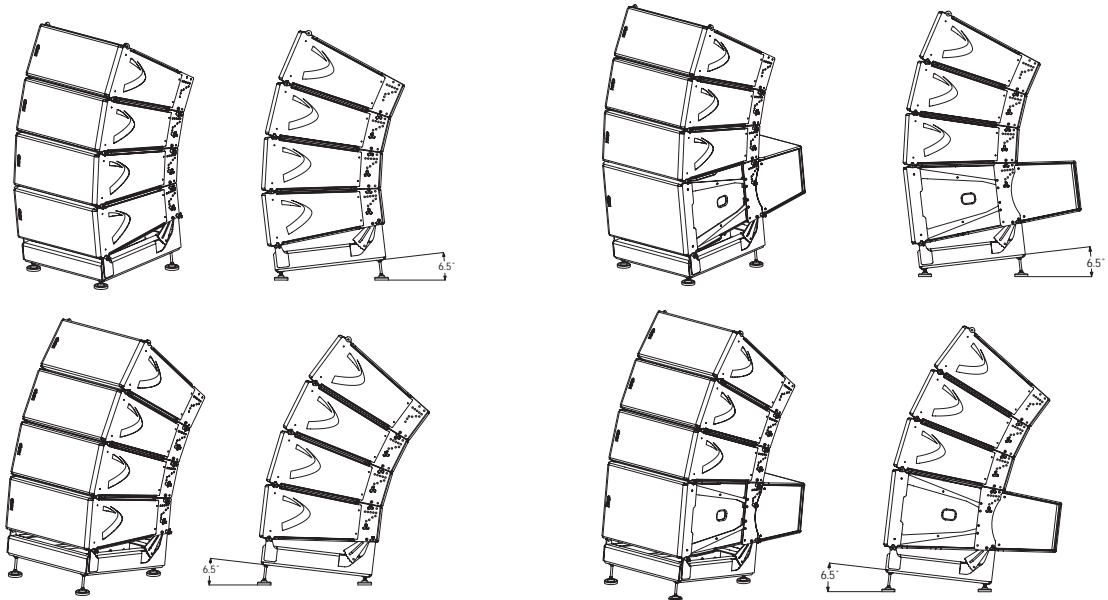

GEO D10

GEO SUB GEO D10

MAXIMUM ALLOWED STACKED CONFIGURATION

5.4 GEO D Cluster Flying Setup (1 motor)

Flying a GEO D10 cluster from 1 motor requires the following accessories:

- 1 x Motor properly rated
- 1 x Geo-Bridle (GEO-BRIDLE)
- 1 x GEO D Main Bumper (GEOD-BUMPER)
- 1 x GEO D Short Extension Bar (GEOD-EXBAR1)
- 1 x GEOD Front Extension Bar if strong positive tilt is required (GEOD-EXBAR4)
- 1 x GEO D Compression Wheel (GEOD-ORP)
- 1 x GEO D Bottom Bumper (GEOD-BTBUMPER)
- 1 x GEO D Chain Lever Hoist (LEVA0750 or LEVA1500)
- 1 x Chain Bag (CHBAG)
- 6 x GEOD push-pins per flown GEO D10 (BLGEOD)
- or 1 x GEOD shoulder bolts and nuts kit for fixed installations per flown GEO D (GEOD-BNFIK)

IMPORTANT

Motor and chain lever hoist must be rated to support the entire cluster weight.
Please check configurations in Geosoft2 for proper motor and chain lever hoists rating.

5.4.1 Allowed “One Rigging Point” Configurations

IMPORTANT

- “One rigging point” mode is strictly limited to GeoD clusters (no Geo Sub allowed);
- Maximum GeoD quantity allowed for this mode is 8;
- Compression Wheel and Bridle are designed for Extension Bar EXBAR1 and must not be used with Extension Bar EXBAR2.

5.4.2 Bumper Assembly

- **Strong bumper positive tilt only;** connect the Front Extension Bar Bumper through the Link Points the with the two axes using corresponding holes (see drawing below), and ensure that these axes are properly locked with supplied “R” clips;

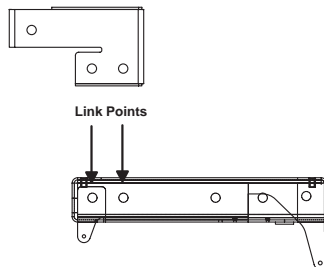

LINKING GEO D BUMPER AND EXTENSION BAR EXBAR4

- Connect the Short Extension Bar EX1 to the Main Bumper through the Link Points the with the two axes using corresponding holes (see drawing below), and ensure that these axes are properly locked with supplied "R" clips;

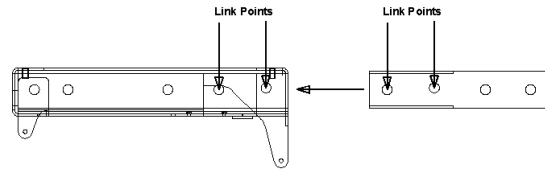

LINKING GEOD BUMPER AND EXTENSION BAR EXBAR1

- Connect the bridle ring to the motor hoist, the bridle adjustable leg to the front rigging point and the bridle fixed length leg to the rear rigging point;
- Attach the chain hook of the LEVA750 or LEVA1500 Chain Lever Hoist to the motor (see drawing below) after passing the chain through Short Extension Bar EX1 behind rear compression point;
- Install the compression wheel by removing the axis located at compression point, inserting the wheel and setting back the axis in position; ensure that the axis is properly locked with supplied "R" clip and that chain is properly located behind the axis;
- Lift the bumper assembly so that top GeoD can be connected at convenient height.

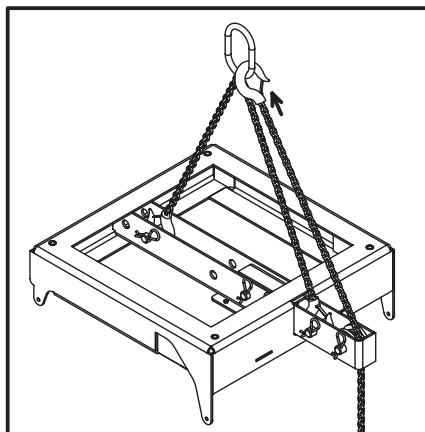
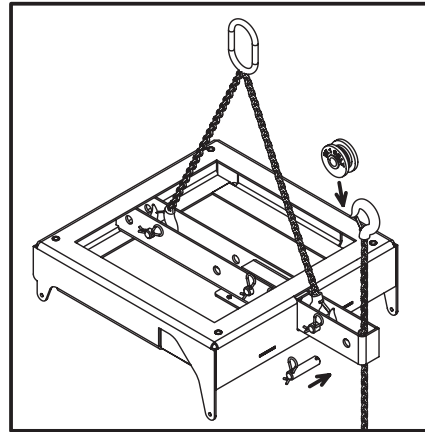
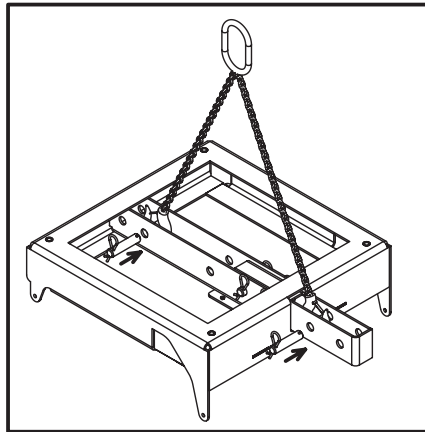

CONNECTING MOTOR, BRIDLE, WHEL AND CHAIN LEVEL HOIST

5.4.3 Bumper to first GEO D10 assembly

IMPORTANT

GEO D10 can be flown "Left" or "Right" :

- "Left" means Nexo logo on front grid is left as seen from front;
- "Right" means Nexo logo on front grid is right as seen from front.

GEO D10 can be connected to bumper "Left" or "Right" by simply flipping the cabinets upside down: do not reverse rigging plates

Whenever possible, NEXO recommends symmetrical designs (preferably NEXO logo inwards in stereo configurations)

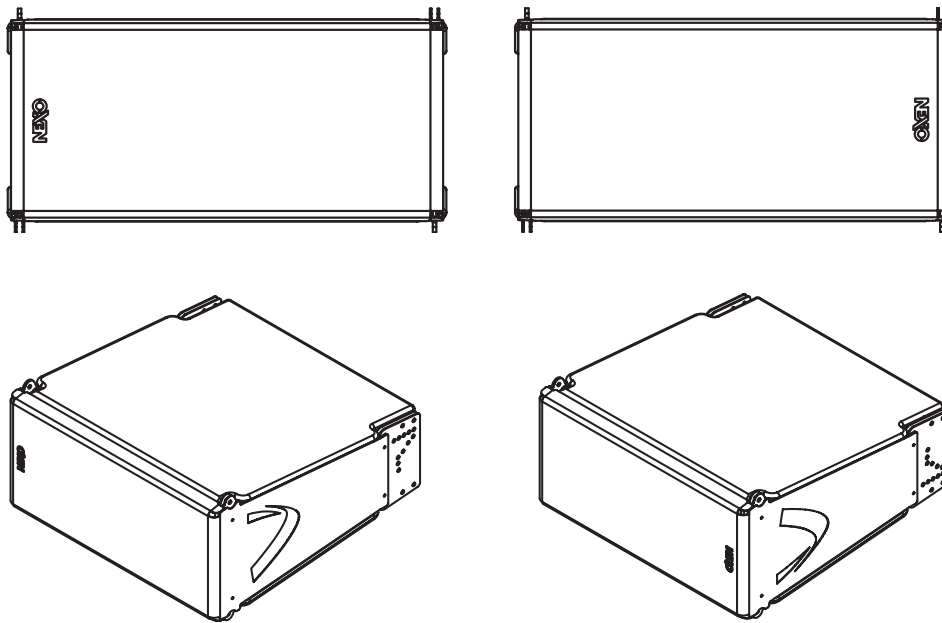

"LEFT" CONFIGURATION

"RIGHT" CONFIGURATION

4 push-pins (BLGEOD, 10mm diameter x 20 mm length) connect the top GEO D10 to the bumper.

- Position the bumper on the first GEO D10 by lifting or lowering bumper assembly with motor hoist;
- Link the GEO D10 to the bumper assembly using the four 10mm x 20mm push-pins; front bumper connects at GEO D10 front articulation point, rear bumper connects at "LIFT" GEO D10 rigging plates holes;
- Check that all push-pins are in their locked position.
- Ensure that no objects have been placed accidentally on the top of the bumper as they may fall when the system is lifted.

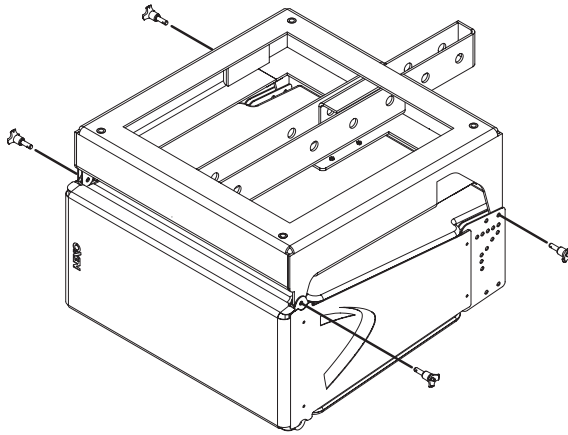

FIRST GEO D10 TO BUMPER ASSEMBLY

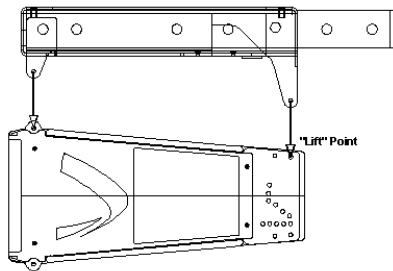

"RIGHT" CONFIGURATION

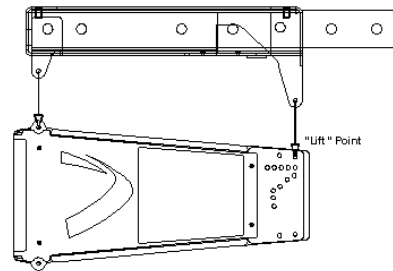

"LEFT" CONFIGURATION

5.4.4 First to second GEO D 10

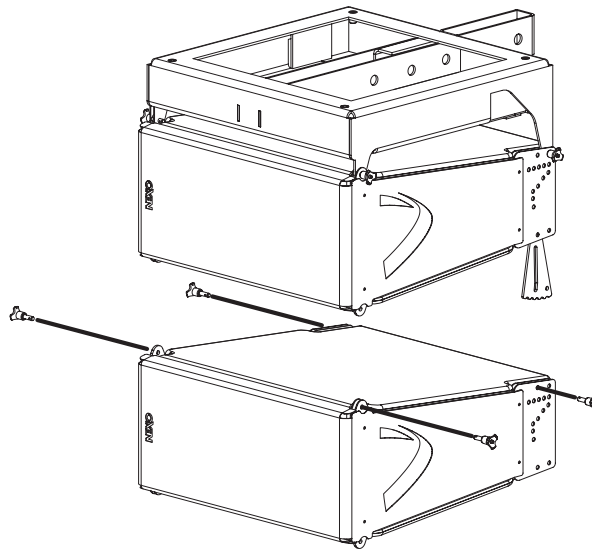

FIRST TO SECOND GEO D10

4 push-pins (BLGEOD, 10mm diameter x 20 mm length) connect first to second GEO D10, 2 additional push pins-are required for angle adjustment.

- Lift bumper and top GEO D10 assembly, and position the next GEO D10 below the assembly, with NEXO logo on the same side than the upper cabinet.
- Lower bumper and top GEO D10 assembly carefully until the first and second GEO D10 side rigging plates locate. Use front grid, rear vent ports or handle to guide the assembly. The rigging plates have been designed to locate against each other and so align the holes correctly.
- Connect the upper GEO D link bar to the lower GEO D rigging plate (or lower link bar to upper rigging plate for "Right" configuration) by inserting one 10mm x 20 mm push-pin in the "SAFETY PIN MUST BE FITTED" hole on each side (see figure below).

IMPORTANT

The push-pins for "SAFETY PIN MUST BE FITTED" holes must always be inserted first and stay in position permanently. NEVER REMOVE THEM ONCE CABINETS ARE SUSPENDED.

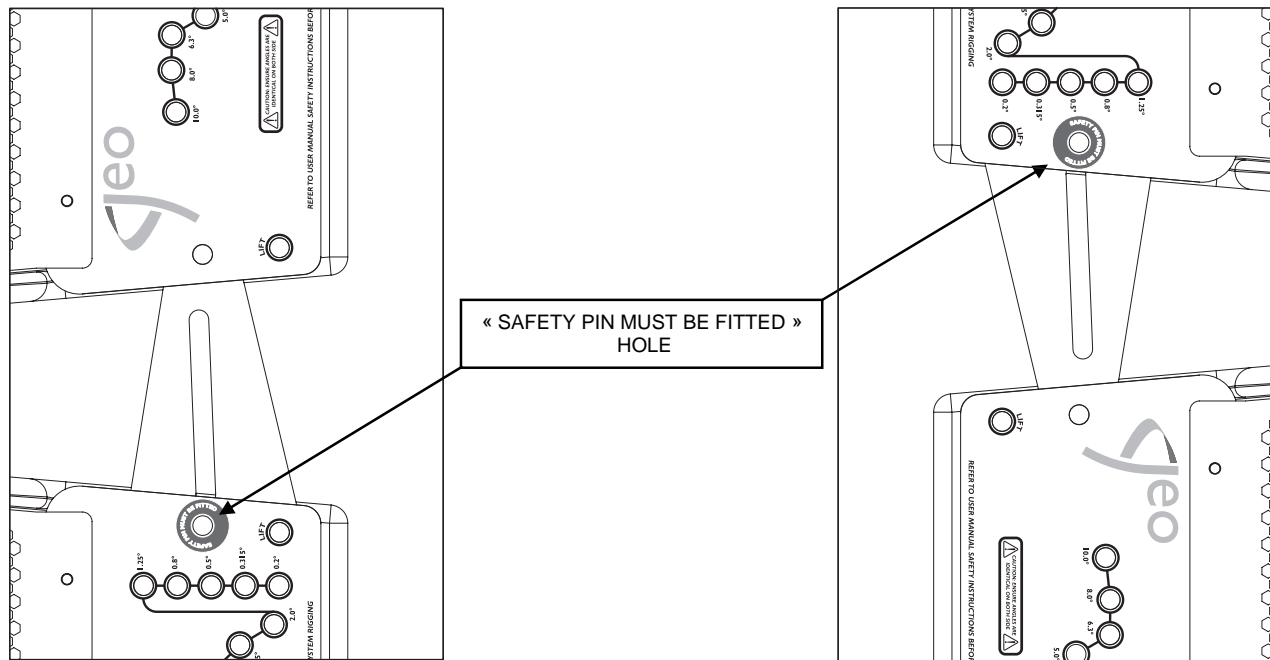

- Insert two additional 10mm x 20mm push-pins in the front holes (see figure above).
- Lift the bumper and two first GEO D10's to a height that allows convenient access to the linking bars and the angle setting holes.
- Insert 1 additional push-pin to the required angle value hole on each side
- Check that all 6 push-pins are locked.

IMPORTANT

Ensure angle settings are identical on both sides of the cabinet.

5.4.5 Subsequent GEO D10's

- Repeat the above section steps, until all GEO D10's are in place. As the assembly is lifted, angles between GEO D10's cabinets will remain at 0° whatever the linking bar positions.
- NB : angle settings are free to be adjusted while the system is clear of the ground, provided that rear pull-up force is not applied.

5.4.6 Applying compression with the Chain Lever Hoist

- Once the GEO D10 assembly is completed, connect the bottom bumper to the last GEO D10 with the 10mm x 20mm push-pins inserted in the "FIX" bottom hole (see drawings below).
- Check the array according to the Checklist procedure described later in this manual.

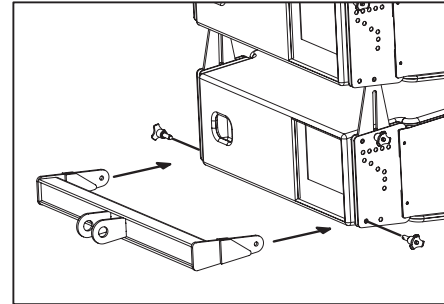
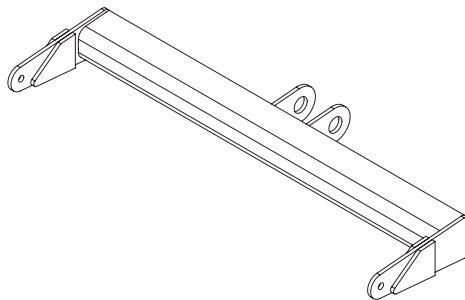

- Attach the main hook of the Chain Lever Hoist to the rear of the Bottom Bumper;
- Manually raise the Bottom Bumper and rotate the fingerwheel clockwise until the chain is taught;
- Make a final check that the Chain Lever Hoist is correctly installed;
- Rotate the lever to apply the pull-up force to the bottom of the array; notice that, as the chain gets shorter, the cabinets in the array close together to the angles set by the angle adjustments push-pins;

As the chainload tensions, ensure that no twisting occurs on the chain;

- Once all of the cabinets are closed together, continuing rotating the lever will tilt the bumper down;
- store the surplus chain in the chain bag supplied. The chain bag should be clipped to the chain.

In case of "Left" configuration, make sure that the bottom link bars cannot hurt anyone going below the cluster. If any doubt, NEXO strongly recommends removing them (screws can be replaced by 10mm x 20mm push-pins to facilitate such change).

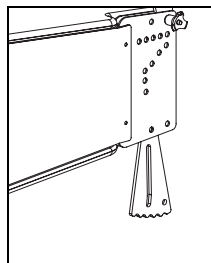

BOTTOM LINK BAR TO BE REMOVED FROM "LEFT" CLUSTERS CONFIGURATION

IMPORTANT

DO NOT attempt to make any changes to the angle adjustments when the compression pull-up force is applied.

5.4.7 Positioning the cluster

- Adjust the bumper angle as determined in GeoSoft2 by rotating the lever from the bottom of the cluster ;
- Check all GEO D angles with an inclinometer;
- Lift the GEO D array to the height determined in GeoSoft2 (GeoSoft2 array height definition is for the top edge of the topmost cabinet);
- Once the bumper is in definitive position a secondary safety steel must be fitted (this secondary safety steel should link the bumper to a suitable point in the supporting structure);

IMPORTANT

The requirements for secondary safety systems vary with territories. However, the secondary safety steel **MUST** have a SWL equivalent to or greater than that of the rigging system.

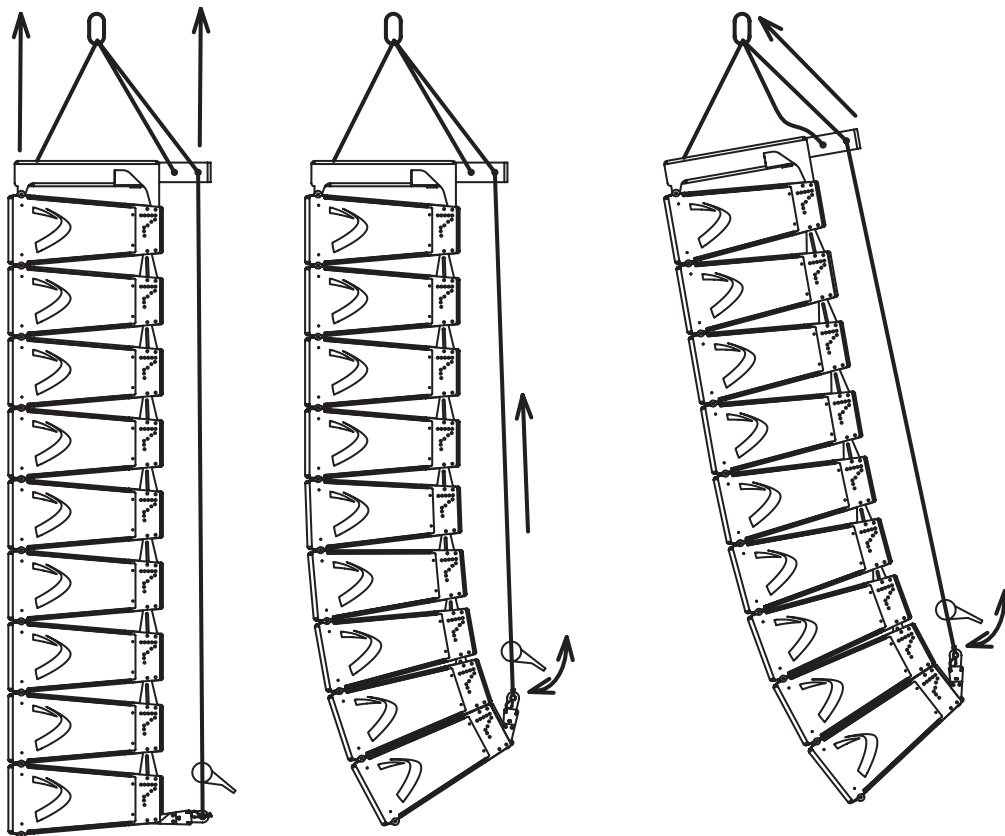

APPLYING COMPRESSION AND SETTING BUMPER ANGLE

5.4.8 De-rigging and loading out

Taking the system down is just a case of doing the reverse procedure to flying the array. However, there are some important factors to consider.

- Lower the array until the bottom cabinet is just off the floor;
- Rotate the chain hoist lever counter-clockwise until bumper is back to horizontal position and no tension is applied on the GEO D compression chain.
- Disconnect the bottom GEO D from the bottom bumper and remove the bottom bumper from the array.

Link cables must be disconnected and stowed away in the recesses in the rear of each cabinet.

- NB : As the system is lowered it is good practise to disconnect as many loudspeaker cables as can be reached without climbing the array. This ensures that a cable should not be accidentally forgotten when the system is separated. Damage to the connector will occur should this mistake be made.
- Angle adjustment push-pins should be removed from the angle setting and inserted in the "FIX" hole so that Geo D's sit flat on the dolly.
- Lift the dolly manually below the array and connect it to the bottom GEO D with 4 push-pins.

Carefully lower the array so that the dolly being on the ground is not being submitted to the entire cluster weight.

- Disconnect the first block of 3 GEO D's at the connection between 3rd and 4th bottom cabinets.
- Carefully lift the array until the array is clear. Ensure the array is vertical at all times.
- Repeat the procedure for all cabinets.
- Remove the GEO D compression chain from the GEO D extension bar, slide the extension bar into the bumper and remember to replace all the axes back in their respective beams.

5.4.9 Rigging and De-rigging with GEOD Dolly Storage Tray

IMPORTANT

GEOD Dolly Storage Tray are designed for 3 or 4 GEO D's + bumper or case ;
GEOSUB Dolly Storage Tray is designed for up to 2 GEO SUB's + bumper or case.
Never exceed these quantities.

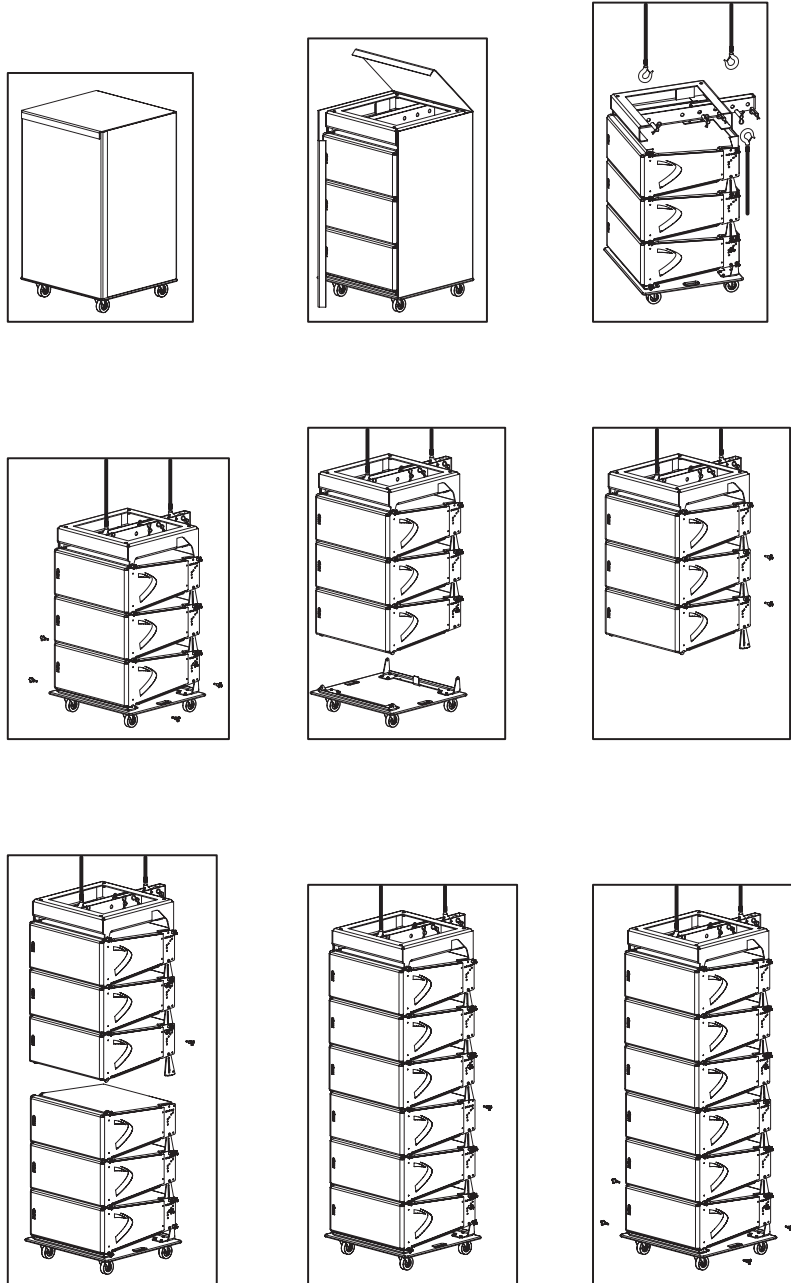

FROM PACKAGED TO FLOWN GEO D10'S

5.5 GEO D Cluster Flying Setup (2 motors)

Flying a GEO D10 cluster from 2 motors requires the following accessories:

- 2 x Motors properly rated
- 1 x GEO D Main Bumper (GEOD-BUMPER)
- 1 x GEO D Short Extension Bar (GEOD-EXBAR1)
- 1 x GEOD Front Extension Bar if strong positive tilt is required (GEOD-EXBAR4)
- 1 x GEO D Bottom Bumper (GEOD-BTBUMPER)
- 1 x GEO D Chain Lever Hoist (LEVA0750 or LEVA1500)
- 1 x Chain Bag (CHBAG)
- 6 x GEOD push-pins per flown GEO D10 (BLGEOD)
- or 1 x GEOD shoulder bolts and nuts kit for fixed installations per flown GEO D (GEOD-BNFIK)

IMPORTANT

Each of front, rear motor and chain lever hoists must be rated to support the entire cluster weight.

Please check configurations in Geosoft2 for proper motor and chain lever hoists rating

5.5.1 Bumper Assembly

- **Strong bumper positive tilt only;** connect the Front Extension Bar Bumper through the Link Points the with the two axes using corresponding holes (see drawing below), and ensure that these axes are properly locked with supplied "R" clips;

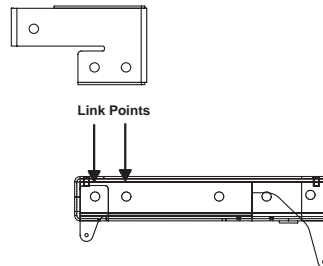

LINKING GEOD BUMPER AND EXTENSION BAR EXBAR4

- Connect the Short Extension Bar EX1 to the Main Bumper through the Link Points the with the two axes using corresponding holes (see drawing below), and ensure that these axes are properly locked with supplied "R" clips;

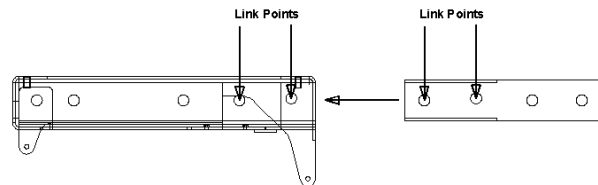

LINKING GEOD BUMPER AND EXTENSION BAR EX1

- Link the motor hoists to the Bumper – Extension Bar assembly to Front and Rear Rigging Points with the two axes using corresponding holes (see drawing below), and ensure that these axes are properly locked with supplied "R" clips;
- Attach the chain hook of the LEVA500 or LEVA1500 Chain Lever Hoist to the Compression Point (see drawing below).

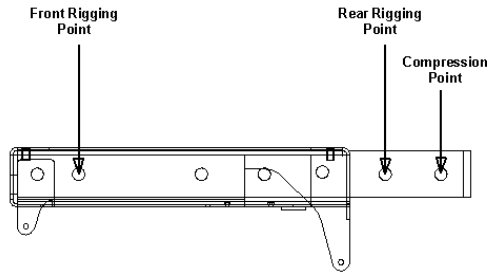

CONNECTING FRONT, REAR MOTORS AND CHAIN LEVEL HOIST

5.5.2 Bumper to first GEO D10 assembly

IMPORTANT

GEO D10 can be flown "Left" or "Right" :

- "Left" means Nexo logo on front grid is left as seen from front;
- "Right" means Nexo logo on front grid is right as seen from front.

GEO D10 can be connected to bumper "Left" or "Right" by simply flipping the cabinets upside down: do not reverse rigging plates

Whenever possible, NEXO recommends symmetrical designs (preferably NEXO logo inwards in stereo configurations)

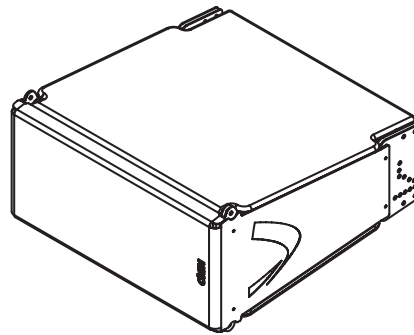
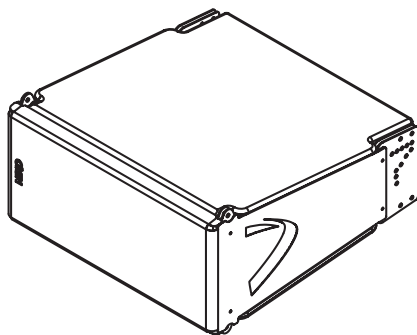

"LEFT" CONFIGURATION

"RIGHT" CONFIGURATION

4 push-pins (BLGEOD, 10mm diameter x 20 mm length) connect the top GEO D10 to the bumper.

- Position the bumper on the first GEO D10 by lifting or lowering bumper assembly with motor hoists;
- Link the GEO D10 to the bumper assembly using the four 10mm x 20mm push-pins; front bumper connects at GEO D10 front articulation point, rear bumper connects at "LIFT" GEO D10 rigging plates holes;
- Check that all push-pins are in their locked position.
- Ensure that no objects have been placed accidentally on the top of the bumper as they may fall when the system is lifted.

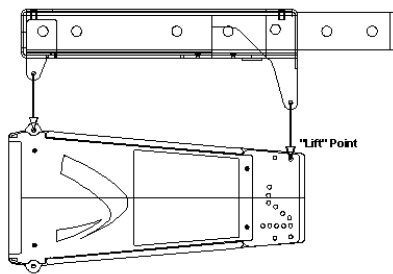
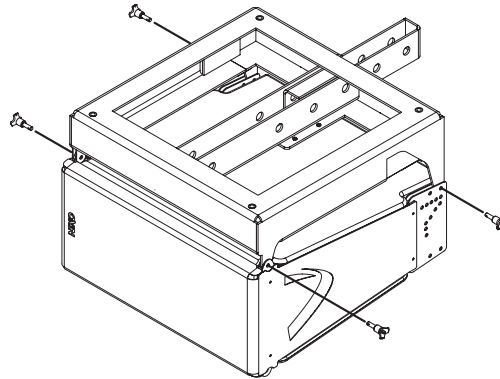

"RIGHT" CONFIGURATION

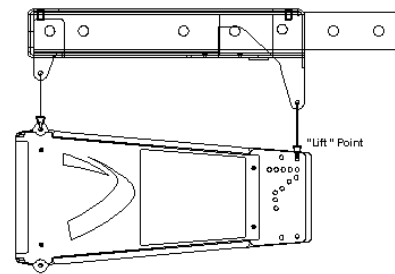

"LEFT" CONFIGURATION

FIRST GEO D10 TO BUMPER ASSEMBLY

5.5.3 First to second GEO D 10

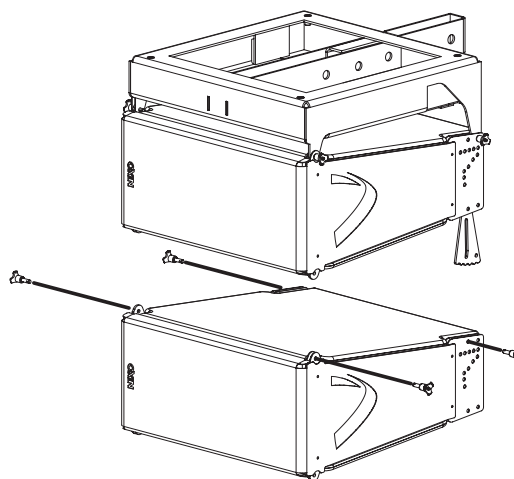

FIRST TO SECOND GEO D10

4 push-pins (BLGEOD, 10mm diameter x 20 mm length) connect first to second GEO D10, 2 additional push pins-are required for angle adjustment.

- Lift bumper and top GEO D10 assembly, and position the next GEO D10 below the assembly, with NEXO logo on the same side than the upper cabinet.
- Lower bumper and top GEO D10 assembly carefully until the first and second GEO D10 side rigging plates locate. Use front grid, rear vent ports or handle to guide the assembly. The rigging plates have been designed to locate against each other and so align the holes correctly.
- Connect the upper GEO D link bar to the lower GEO D rigging plate (or lower link bar to upper rigging plate for “Right” configuration) by inserting one 10mm x 20 mm push-pin in the “SAFETY PIN MUST BE FITTED” hole on each side (see figure below).

IMPORTANT

The push-pins for “SAFETY PIN MUST BE FITTED” holes must always be inserted first and stay in position permanently. NEVER REMOVE THEM ONCE CABINETS ARE SUSPENDED.

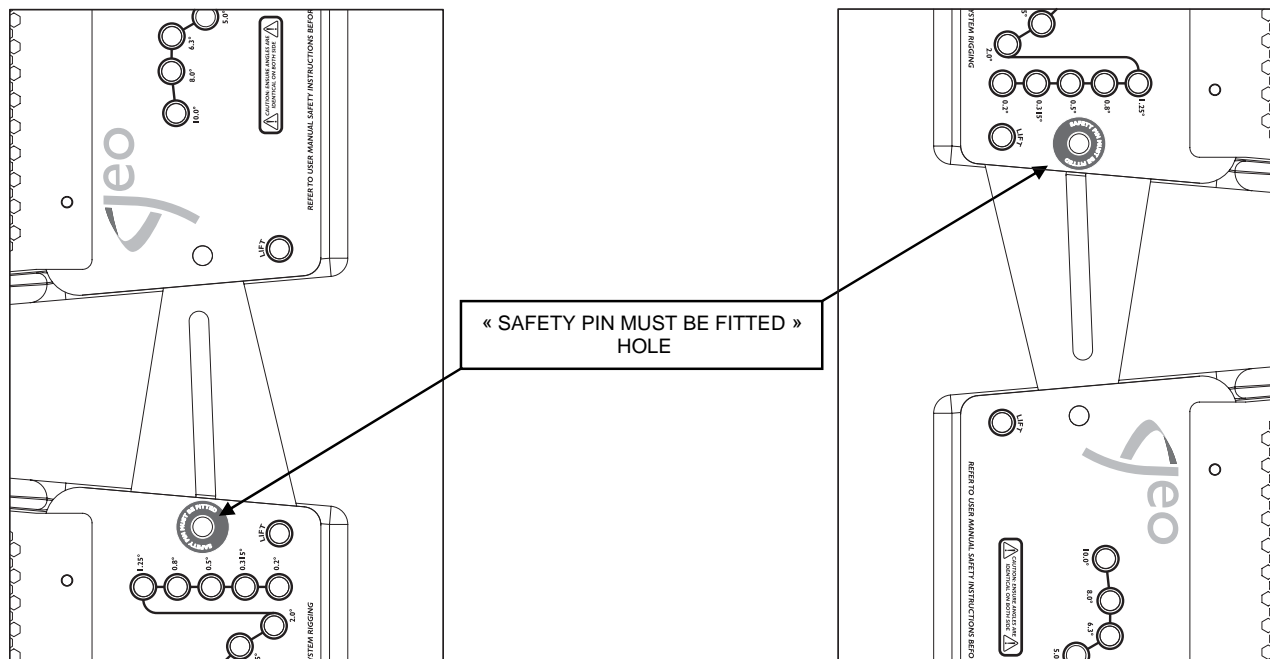

- Insert two additional 10mm x 20mm push-pins in the front holes (see figure above).
- Lift the bumper and two first GEO D10's to a height that allows convenient access to the linking bars and the angle setting holes.
- Insert 1 additional push-pin to the required angle value hole on each side
- Check that all 6 push-pins are locked.

IMPORTANT

Ensure angle settings are identical on both sides of the cabinet.

5.5.4 Subsequent GEO D10's

- Repeat the above section steps, until all GEO D10's are in place. As the assembly is lifted, angles between GEO D10's cabinets will remain at 0° whatever the linking bar positions.
- NB : angle settings are free to be adjusted while the system is clear of the ground, provided that rear pull-up force is not applied.

5.5.5 Applying compression with the Chain Lever Hoist

- Once the GEO D10 assembly is completed, connect the bottom bumper to the last GEO D10 with the 10mm x 20mm push-pins inserted in the "FIX" bottom hole (see drawings below).
- Check the array according to the Checklist procedure described later in this manual.

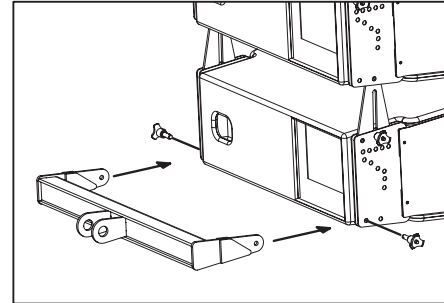
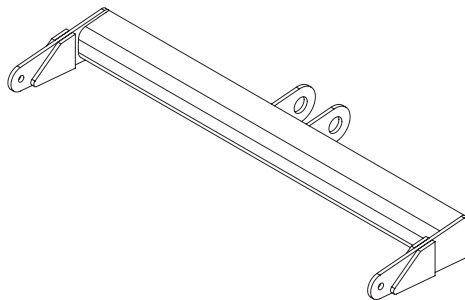

- Attach the main hook of the Chain Lever Hoist to the rear of the Bottom Bumper;
- Manually raise the Bottom Bumper and rotate the fingerwheel clockwise until the chain is taught;
- Make a final check that the Chain Lever Hoist is correctly installed;
- Rotate the lever to apply the pull-up force to the bottom of the array; notice that, as the chain gets shorter, the cabinets in the array close together to the angles set by the angle adjustments push-pins;

As the chainload tensions, ensure that no twisting occurs on the chain;

- When all of the cabinets are closed together, required force to rotate the lever becomes much stronger. This is the indication that the angles have been correctly set;
- store the surplus chain in the chain bag supplied. The chain bag should be clipped to the chain.

In case of "Left" configuration, make sure that the bottom link bars cannot hurt anyone going below the cluster. If any doubt, NEXO strongly recommends removing them (screws can be replaced by 10mm x 20mm push-pins to facilitate such change).

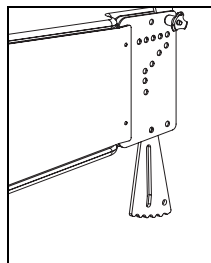

BOTTOM LINK BAR TO BE REMOVED FROM "LEFT" CLUSTERS CONFIGURATION

IMPORTANT

DO NOT attempt to force on LEVA750 or LEVA1500 lever once you feel it resisting strongly to rotation; you might damage GEO D flying system by doing so.

IMPORTANT

DO NOT attempt to make any changes to the angle adjustments when the compression pull-up force is applied.

5.5.6 Positioning the cluster

- Lift the GEO D array to the height determined in GeoSoft (GeoSoft array height definition is for the top surface of the topmost cabinet);
- Adjust the bumper angle as determined in GeoSoft by lowering or lifting rear motor hoist (so that the front height does not change);
- Check all GEO D angles with an inclinometer;
- Once the bumper is in definitive position a secondary safety steel must be fitted (this secondary safety steel should link the bumper to a suitable point in the supporting structure);

IMPORTANT

The requirements for secondary safety systems vary with territories. However, the secondary safety steel **MUST** have a SWL equivalent to or greater than that of the rigging system.

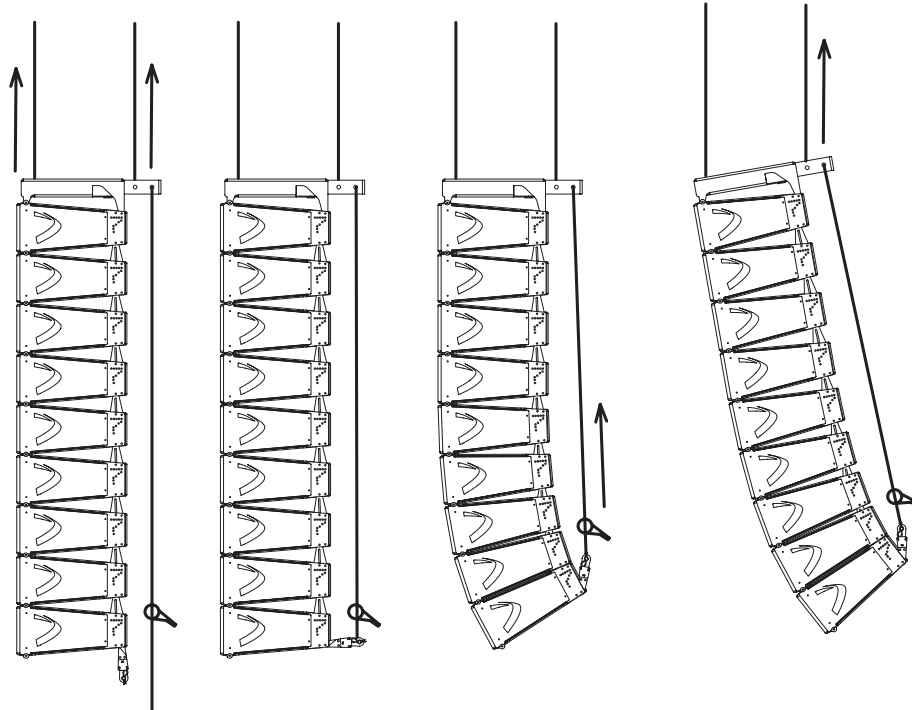

APPLYING COMPRESSION AND SETTING BUMPER ANGLE

5.5.7 De-rigging and loading out

Taking the system down is just a case of doing the reverse procedure to flying the array. However, there are some important factors to consider.

- Lower the array running the two motor hoists simultaneously until the bottom cabinet is just off the floor, main bumper being horizontal.
- Rotate the chain hoist lever counter-clockwise until there is no tension on the GEO D compression chain and no compression on the system.
- Disconnect the bottom GEO D from the bottom bumper and remove the bottom bumper from the array.

Link cables must be disconnected and stowed away in the recesses in the rear of each cabinet.

- NB : As the system is lowered it is good practise to disconnect as many loudspeaker cables as can be reached without climbing the array. This ensures that a cable should not be accidentally forgotten when the system is separated. Damage to the connector will occur should this mistake be made.
- Angle adjustment push-pins should be removed from the angle setting and inserted in the "FIX" hole so that Geo D's sit flat on the dolly.
- Lift the dolly manually below the array and connect it to the bottom GEO D with 4 push-pins.

Carefully lower the array so that the dolly being on the ground is not being submitted to the entire cluster weight.

- Disconnect the first block of 3 GEO D's at the connection between 3rd and 4th bottom cabinets.
- Carefully lift the array using both motor hoists until the array is clear. Ensure the array is vertical at all times.
- Repeat the procedure for all cabinets.
- Remove the GEO D compression chain from the GEO D extension bar, slide the extension bar into the bumper and remember to replace all the axes back in their respective beams.

5.5.8 Rigging and De-rigging with GEOD Dolly Storage Tray

IMPORTANT

GEOD Dolly Storage Tray are designed for 3 or 4 GEO D's + bumper or case ;
GEOSUB Dolly Storage Tray is designed for up to 2 GEO SUB's + bumper or case.
Never exceed these quantities.

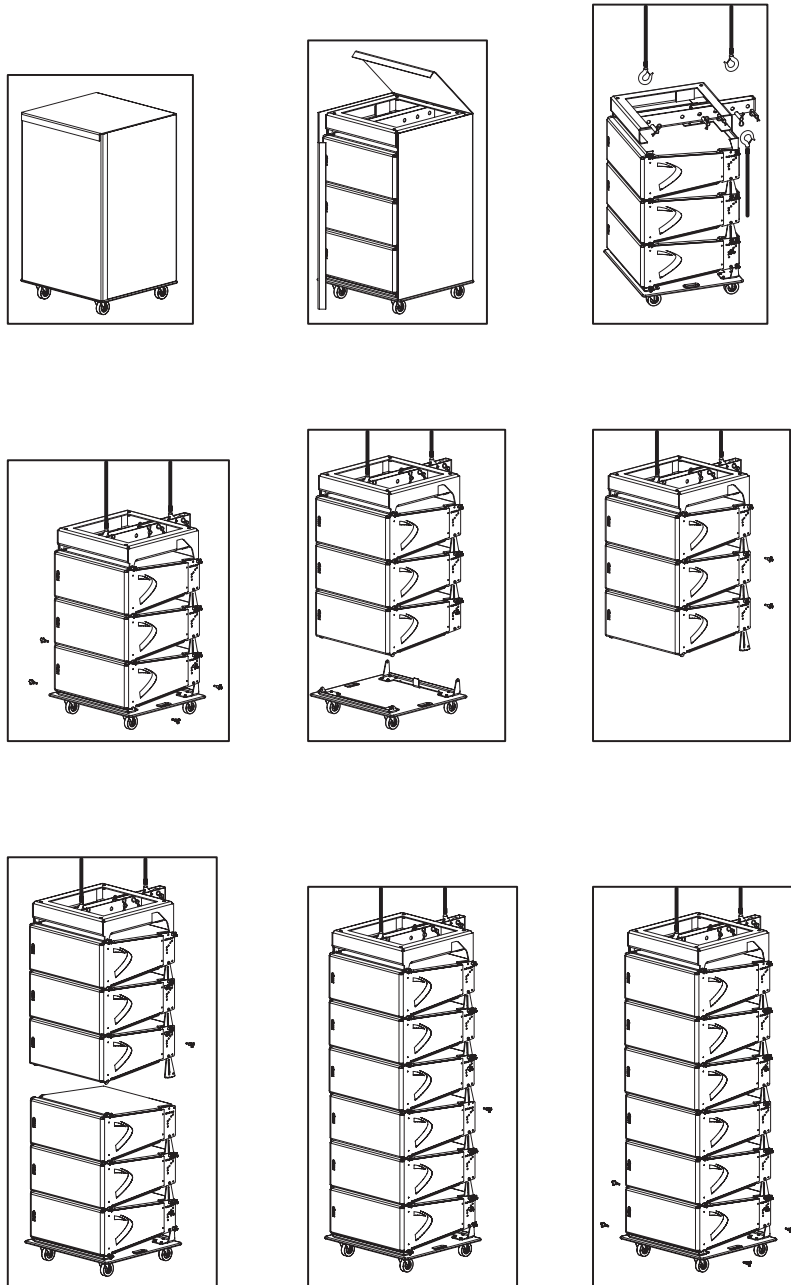

FROM PACKAGED TO FLOWN GEO D10'S

5.6 GEO SUB – GEO D Combined Cluster Flying Setup (2 motors required)

Flying a GEO SUB – GEO D combined cluster is very similar to what has been described in the above section, except a long Extension Bar EX2 (instead of EX1) is required to extend top compression point because of GEO SUB depth.

However, the section below details all steps to be completed for a safe setup.

Flying a combined GEO D10 / GEO SUB cluster requires:

- 2 x Motors properly rated
- 1 x GEO D Main Bumper (GEOD-BUMPER)
- 1 x GEO D long Extension Bar (GEOD-EXBAR2)
- 1 x GEOD Front Extension Bar if strong positive tilt is required (GEOD-EXBAR4)
- 1 x GEO D Bottom Bumper (GEOD-BTBUMPER)
- 1 x GEO D Chain Lever Hoist (LEVA0750 or LEVA1500)
- 1 x Chain Bag (CHBAG)
- 6 x GEOD push-pins per flown GEO SUB (BLGEOD)
- or 1 x GEOD shoulder bolts and nuts kit for fixed installations per flown GEO D (GEOD-BNFIK)

IMPORTANT

Each of front, rear motor and chain lever hoists must be rated to support the entire cluster weight.

Please check configurations in Geosoft2 for proper motor and chain lever hoists rating

5.6.1 Bumper Assembly

- **Strong bumper positive tilt only;** connect the Front Extension Bar Bumper through the Link Points the with the two axes using corresponding holes (see drawing below), and ensure that these axes are properly locked with supplied “R” clips;

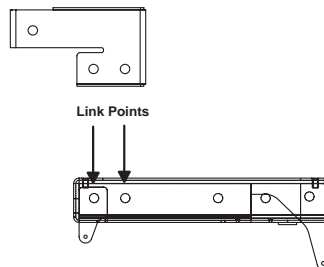

LINKING GEOD BUMPER AND EXTENSION BAR EXBAR4

- Connect the Long Extension Bar to the Main Bumper through the Link Points the with the two axes using corresponding holes (see drawing below), and ensure that these axes are properly locked with supplied “R” clips;

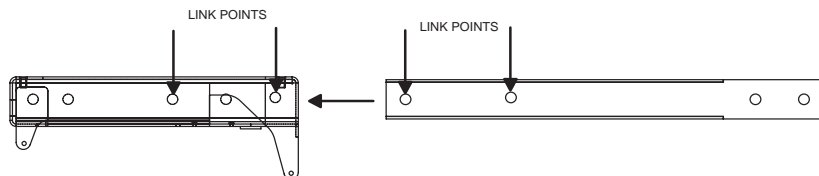

LINKING GEOD BUMPER AND EXTENSION BAR EX2

- If strong positive tilt is required, front rigging point as to be extended further; connect the Front Extension Bar Bumper through the Link Points the with the two axes using corresponding holes (see drawing below), and ensure that these axes are properly locked with supplied “R” clips;
- Link the motor hoists to the Bumper – Extension Bar assembly to Front and Rear Rigging Points with the two axes using corresponding holes (see drawing below), and ensure that these axes are properly locked with supplied “R” clips;
- Attach the chain hook of the LEVA750 or LEVA1500 Chain Lever Hoist to the Compression Point (see drawing below).

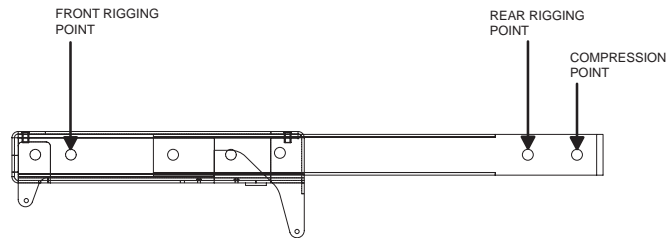

CONNECTING FRONT, REAR MOTORS AND CHAIN LEVEL HOIST

5.6.2 Bumper to first GEO SUB assembly

IMPORTANT

GEO D10 and GEO SUB can be flown “Left” or “Right” :

- “Left” means Nexo logo on front grid is left as seen from front;
- “Right” means Nexo logo on front grid is right as seen from front.

GEO D10 and GEO SUB can be connected to bumper “Left” or “Right” by simply flipping the cabinets upside down: do not reverse rigging plates

Whenever possible, NEXO recommends symmetrical designs (preferably NEXO logo inwards in stereo configurations)

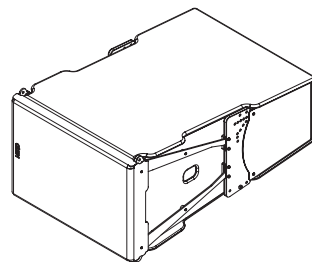
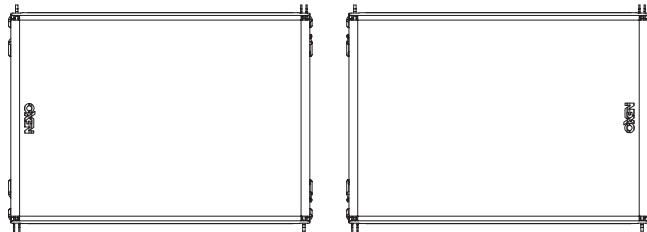

“LEFT” CONFIGURATION

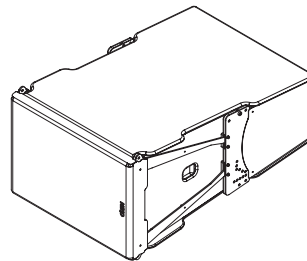

“RIGHT” CONFIGURATION

4 push-pins (BLGEOD, 10mm diameter x 20 mm length) connect the top GEO SUB to the bumper.

- Position the bumper on the first GEO SUB by lifting or lowering bumper assembly with motor hoists;
- Link the GEO SUB to the bumper assembly using the four 10mm x 20mm push-pins; front bumper connects at GEO SUB front articulation point, rear bumper connects at "LIFT" GEO SUB rigging plates holes;
- Check that all push-pins are in their locked position.
- Ensure that no objects have been placed accidentally on the top of the bumper as they may fall when the system is lifted.

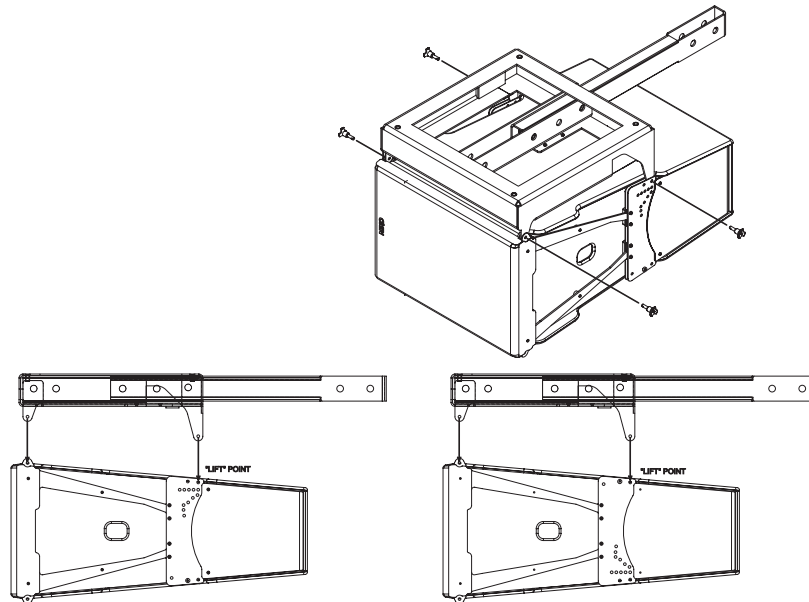

FIRST GEO SUB TO BUMPER ASSEMBLY

"LEFT" CONFIGURATION

"RIGHT" CONFIGURATION

5.6.3 First to second GEO SUB

4 push-pins (BLGEOD, 10mm diameter x 20 mm length) connect first to second GEO SUB, 2 additional push pins-are required for angle adjustment.

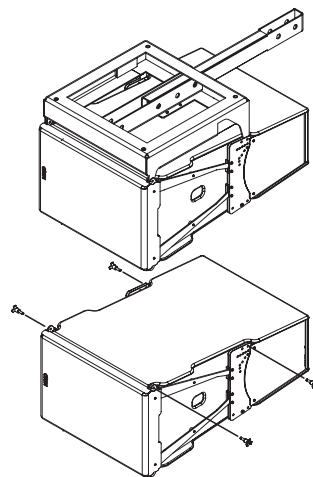

FIRST TO SECOND GEO SUB

- Lift bumper and top GEO SUB assembly, and position the next GEO SUB below the assembly, with NEXO logo on the same side than the upper cabinet.
- Lower bumper and top GEO SUB assembly carefully until the first and second GEO SUB side rigging plates locate. Use front grid, rear vent ports or handle to guide the assembly. The rigging plates have been designed to locate against each other and so align the holes correctly.
- Connect the upper GEO SUB link bar to the lower GEO SUB rigging plate (or lower link bar to upper rigging plate for "Right" configuration) by inserting one 10mm x 20 mm push-pin in the "SAFETY PIN MUST BE FITTED" hole on each side (see figure below).

IMPORTANT

The push-pins for "SAFETY PIN MUST BE FITTED" holes must always be inserted first and stay in position permanently. NEVER REMOVE THEM ONCE CABINETS ARE SUSPENDED.

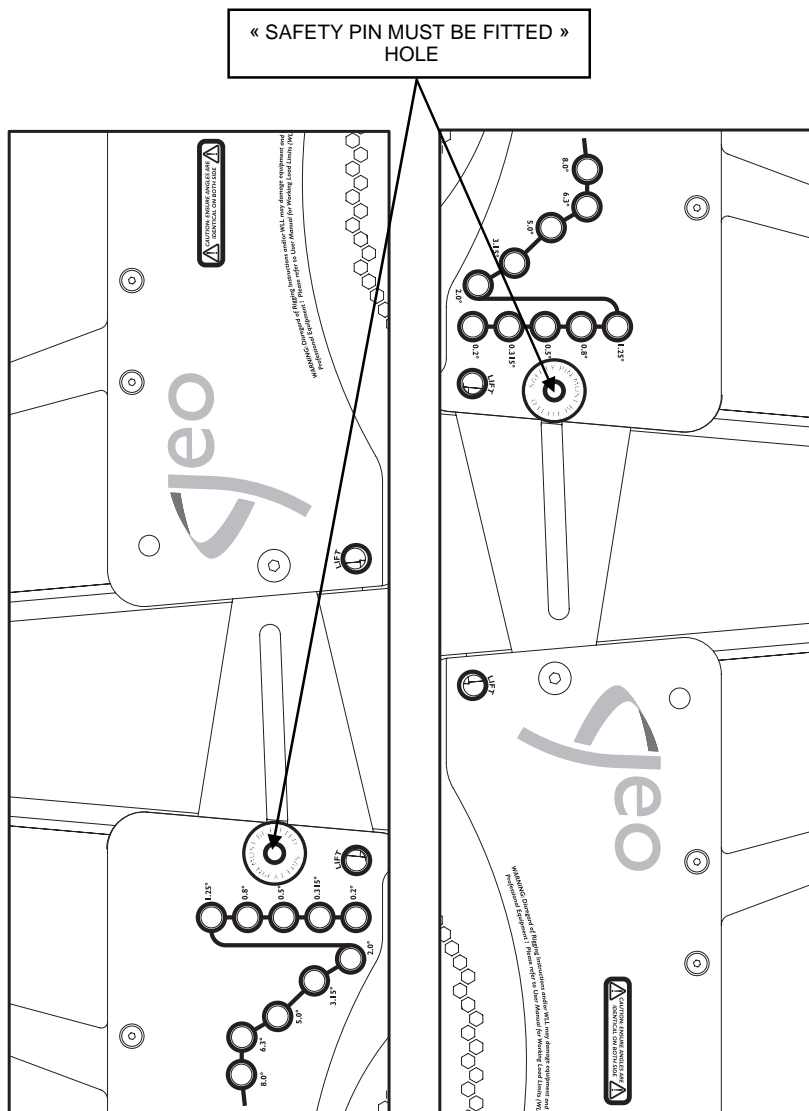

- Insert two additional 10mm x 20mm push-pins in the front holes (see figure above).
- Lift the bumper and two first GEO SUB's to a height that allows convenient access to the linking bars and the angle setting holes.
- Insert 1 additional push-pin to the required angle value hole on each side
- Check that all 6 push-pins are locked.

IMPORTANT

Ensure angle settings are identical on both sides of the cabinet.

5.6.4 Last GEO SUB to First GEO D10

4 push-pins (BLGEOD, 10mm diameter x 20 mm length) connect first to second GEO SUB, 2 additional push pins-are required for angle adjustment.

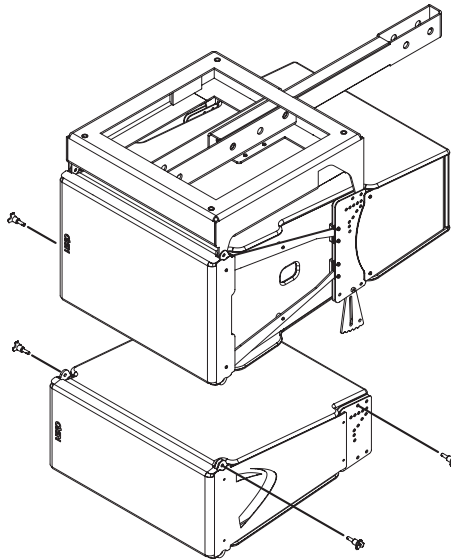

LAST GEO SUB TO FIRST GEO D

- Lift bumper and top GEO SUB assembly, and position the next GEO SUB below the assembly, with NEXO logo on the same side than the upper cabinet.
- Lower bumper and top GEO SUB assembly carefully until the GEO SUB and GEO D10 side rigging plates locate. Use front grid, rear vent ports or handle to guide the assembly. The rigging plates have been designed to locate against each other and so align the holes correctly.
- Connect the upper GEO SUB link bar to the lower GEO D10 rigging plate (or lower link bar to upper rigging plate for "Right" configuration) by inserting one 10mm x 20 mm push-pin in the "SAFETY PIN MUST BE FITTED" hole on each side (see figure below).

IMPORTANT

The push-pins for "SAFETY PIN MUST BE FITTED" holes must always be inserted first and stay in position permanently.

- Insert two additional 10mm x 20mm push-pins in the front holes (see figure above).
- Lift the cluster to a height that allows convenient access to the linking bars and the angle setting holes.
- Insert 1 additional push-pin to the required angle value hole on each side
- Check that all 6 push-pins are locked.

IMPORTANT

Ensure angle settings are identical on both sides of the cabinet.

5.6.5 First to second GEO D 10

4 push-pins (BLGEOD, 10mm diameter x 20 mm length) connect first to second GEO D10, 2 additional push pins-are required for angle adjustment.

- Lift cluster, and position the next GEO D10 below the assembly, with NEXO logo on the same side than the upper cabinet.
- Lower cluster carefully until the first and second GEO D10 side rigging plates locate. Use front grid, rear vent ports or handle to guide the assembly. The rigging plates have been designed to locate against each other and so align the holes correctly.
- Connect the upper GEO D link bar to the lower GEO D rigging plate (or lower link bar to upper rigging plate for "Right" configuration) by inserting one 10mm x 20 mm push-pin in the "SAFETY PIN MUST BE FITTED" hole on each side (see figure below).

IMPORTANT

The push-pins for "SAFETY PIN MUST BE FITTED" holes must always be inserted first and stay in position permanently. NEVER REMOVE THEM ONCE CABINETS ARE SUSPENDED.

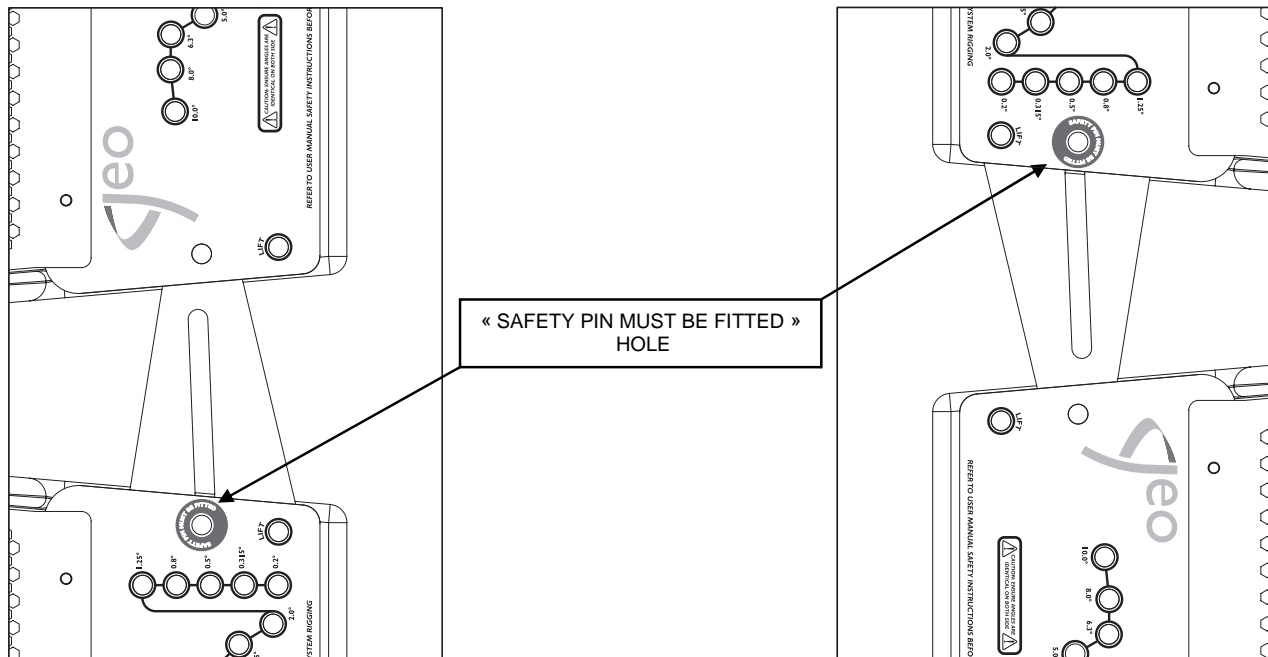

- Insert two additional 10mm x 20mm push-pins in the front holes (see figure above).
- Lift the cluster to a height that allows convenient access to the linking bars and the angle setting holes.
- Insert 1 additional push-pin to the required angle value hole on each side
- Check that all 6 push-pins are locked.

IMPORTANT

Ensure angle settings are identical on both sides of the cabinet.

5.6.6 Subsequent GEO D10's

- Repeat the above section steps, until all GEO D10's are in place. As the assembly is lifted, angles between GEO D10's cabinets will remain at 0° whatever the linking bar positions.
- NB : angle settings are free to be adjusted while the system is clear of the ground, provided that rear pull-up force is not applied.

5.6.7 Applying compression with the Chain Lever Hoist

- Once the GEO SUB / GEO D10 assembly is completed, connect the bottom bumper to the bottom GEO D10 with the 10mm x 20mm push-pins inserted in the "FIX" bottom hole (see drawings below).
- Check the array according to the Checklist procedure described later in this manual.

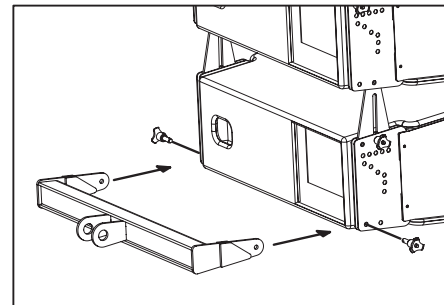
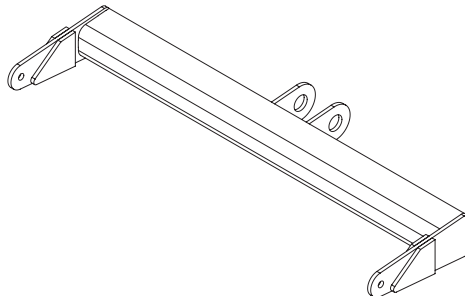

- Attach the main hook of the Chain Lever Hoist to the rear of the Bottom Bumper;
- Manually raise the Bottom Bumper and rotate the fingerwheel clockwise until the chain is taut;
- Make a final check that the Chain Lever Hoist is correctly installed;
- Rotate the lever to apply the pull-up force to the bottom of the array; notice that, as the chain gets shorter, the cabinets in the array close together to the angles set by the angle adjustments push-pins;

As the chainload tensions, ensure that no twisting occurs on the chain;

- When all of the cabinets are closed together, required force to rotate the lever becomes much stronger. This is the indication that the angles have been correctly set;
- store the surplus chain in the chain bag supplied. The chain bag should be clipped to the chain.

In case of "Left" configuration, make sure that the bottom link bars cannot hurt anyone going below the cluster. If any doubt, NEXO strongly recommends removing them (screws can be replaced by 10mm x 20mm push-pins to facilitate such change).

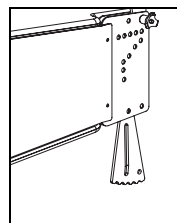

BOTTOM LINK BAR TO BE REMOVED FROM "LEFT" CLUSTERS CONFIGURATION

IMPORTANT

DO NOT attempt to force on LEVA750 or LEVA1500 lever once you feel it resisting strongly to rotation; you might damage GEO D flying system by doing so

IMPORTANT

DO NOT attempt to make any changes to the angle adjustments when the compression pull-up force is applied.

5.6.8 Positioning the cluster

- Lift the GEO SUB / GEO D array to the height determined in GeoSoft (GeoSoft array height definition is for the top surface of the topmost cabinet);
- Adjust the bumper angle as determined in GeoSoft by lowering or lifting rear motor hoist (so that the front height does not change);
- Check all GEO SUB & GEO D angles with an inclinometer;
- Once the bumper is in definitive position a secondary safety steel must be fitted (this secondary safety steel should link the bumper to a suitable point in the supporting structure);

IMPORTANT

The requirements for secondary safety systems vary with territories. However, the secondary safety steel **MUST** have a SWL equivalent to or greater than that of the rigging system.

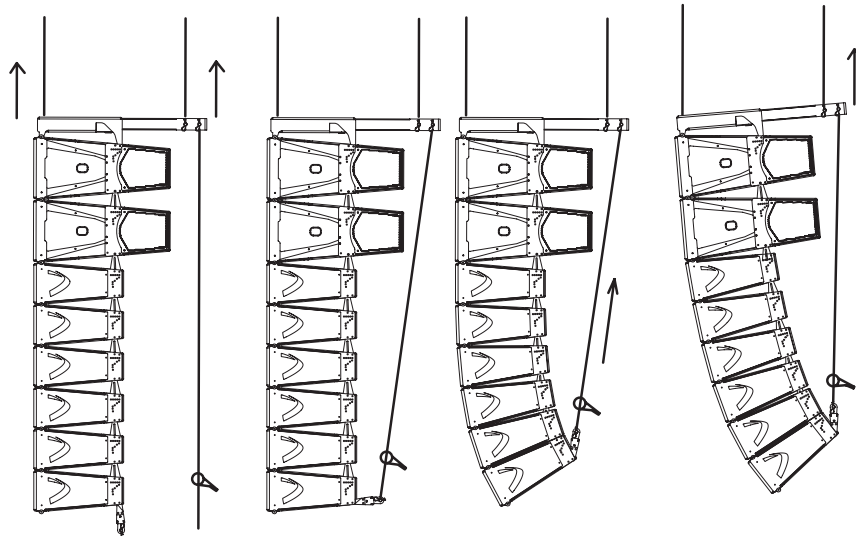

APPLYING COMPRESSION AND SETTING BUMPER ANGLE

5.6.9 De-rigging and loading out

Taking the system down is just a case of doing the reverse procedure to flying the array. However, there are some important factors to consider.

- Lower the array running the two motor hoists simultaneously until the bottom cabinet is just off the floor, main bumper being horizontal.
- Rotate the chain hoist lever counter-clockwise until there is no tension on the compression chain and no compression on the system.
- Disconnect the bottom GEO D from the bottom bumper and remove the bottom bumper from the array.

Link cables must be disconnected and stowed away in the recesses in the rear of each cabinet.

- NB : As the system is lowered it is good practise to disconnect as many loudspeaker cables as can be reached without climbing the array. This ensures that a cable should not be accidentally forgotten when the system is separated. Damage to the connector will occur should this mistake be made.
- Angle adjustment push-pins should be removed from the angle setting and inserted in the "FIX" hole so that Geo D's sit flat on the dolly.
- Lift the dolly manually below the array and connect it to the bottom GEO D with 4 push-pins.

Carefully lower the array so that the dolly being on the ground is not being submitted to the entire cluster weight.

- Disconnect the first block of 3 GEO D's at the connection between 3rd and 4th bottom cabinets.
- Carefully lift the array using both motor hoists until the array is clear. Ensure the array is vertical at all times.
- Repeat the procedure for all cabinets.
- Remove the GEO D compression chain from the GEO D extension bar EX2, slide the extension bar into the bumper and remember to replace all the axes back in their respective beams.

5.7 GEO SUB Cluster Flying Setup (2 motors required)

Flying a GEO SUB cluster is very similar to what has been described in the above sections, except:

- *Long Extension Bar EX2 (instead of EX1) has to be used to extend compression point because of GEO SUB depth;*
- *An additional GEO D Main bumper and a Bottom Extension Bar EX3 replace the GEO D bottom bumper (bottom compression point being much further from the GEO SUB rigging plates, bottom pick up point has to be a lot stronger)*

However, the section below details all steps to be completed for a safe setup.

Flying a GEO SUB cluster requires:

- 2 x Motors properly rated
- 2 x GEO D Main Bumper (GEOD-BUMPER)
- 1 x GEO D Long Extension Bar (GEOD-EXBAR2)
- 1 x GEOD Front Extension Bar if strong positive tilt is required (GEOD-EXBAR4)
- 1 x GEO D Bottom Extension Bar (GEOD-EXBAR3)
- 1 x GEO D Chain Lever Hoist (LEVA0750 or LEVA1500)
- 1 x Chain Bag (CHBAG)
- 6 x GEOD push-pins per flown GEO SUB + 2 GEO push-pins for bottom GEO SUB (BLGEOD)
- or 1 x GEOD shoulder bolts and nuts kit for fixed installations per flown GEO SUB (GEOD-BNFX)

IMPORTANT

Each of front, rear motor and chain lever hoists must be rated to support the entire cluster weight.

Please check configurations in Geosoft2 for proper motor and chain lever hoists rating

5.7.1 Bumper Assembly

- **Strong bumper positive tilt only;** connect the Front Extension Bar Bumper through the Link Points the with the two axes using corresponding holes (see drawing below), and ensure that these axes are properly locked with supplied "R" clips;

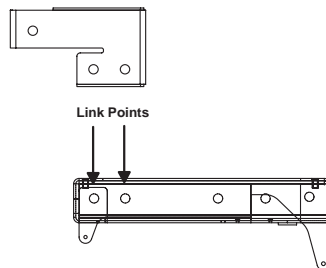

LINKING GEOD BUMPER AND EXTENSION BAR EXBAR4

- Connect the Long Extension Bar EX2 to the Main Bumper through the Link Points the with the two axes using corresponding holes (see drawing below), and ensure that these axes are properly locked with supplied “R” clips;

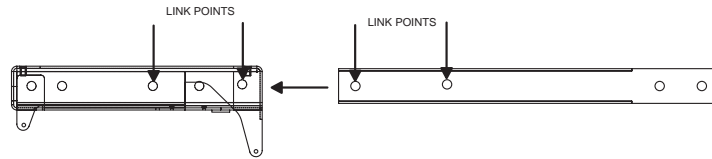

LINKING GEOD BUMPER AND EXTENSION BAR EX2

- If strong positive tilt is required, front rigging point as to be extended further; connect the Front Extension Bar Bumper through the Link Points the with the two axes using corresponding holes (see drawing below), and ensure that these axes are properly locked with supplied “R” clips;
- Link the motor hoists to the Bumper – Extension Bar assembly to Front and Rear Rigging Points with the two axes using corresponding holes (see drawing below), and ensure that these axes are properly locked with supplied “R” clips;
- Attach the chain hook of the LEVA750 or LEVA1500 Chain Lever Hoist to the Compression Point (see drawing below).

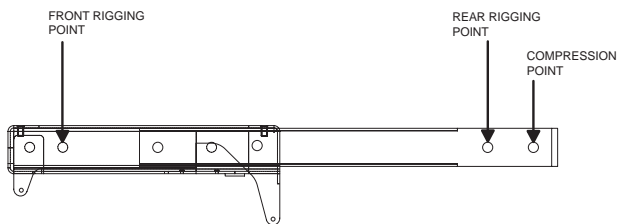

CONNECTING FRONT, REAR MOTORS AND CHAIN LEVEL HOIST

5.7.2 Bumper to first GEO SUB assembly

IMPORTANT

GEO SUB can be flown “Left” or “Right” :

- “Left” means Nexo logo on front grid is left as seen from front;
- “Right” means Nexo logo on front grid is right as seen from front.

GEO SUB can be connected to bumper “Left” or “Right” by simply flipping the cabinets upside down: do not reverse rigging plates

Whenever possible, NEXO recommends symmetrical designs (preferably NEXO logo inwards in stereo configurations)

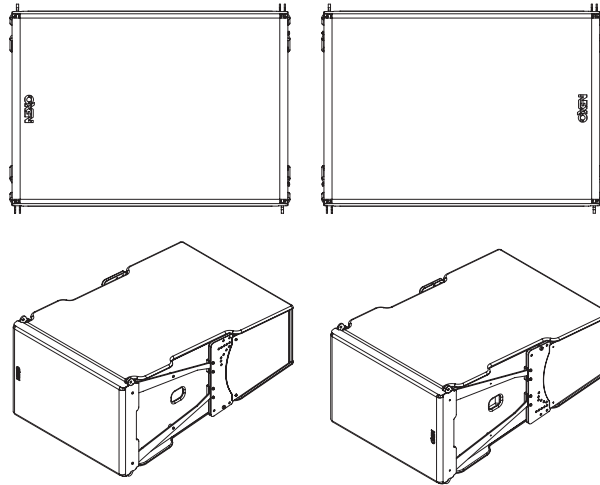

"LEFT" CONFIGURATION

"RIGHT" CONFIGURATION

4 push-pins (BLGEOD, 10mm diameter x 20 mm length) connect the top GEO SUB to the bumper.

- Position the bumper on the first GEO SUB by lifting or lowering bumper assembly with motor hoists;
- Link the GEO SUB to the bumper assembly using the four 10mm x 20mm push-pins; front bumper connects at GEO SUB front articulation point, rear bumper connects at "LIFT" GEO SUB rigging plates holes;
- Check that all push-pins are in their locked position.
- Ensure that no objects have been placed accidentally on the top of the bumper as they may fall when the system is lifted.

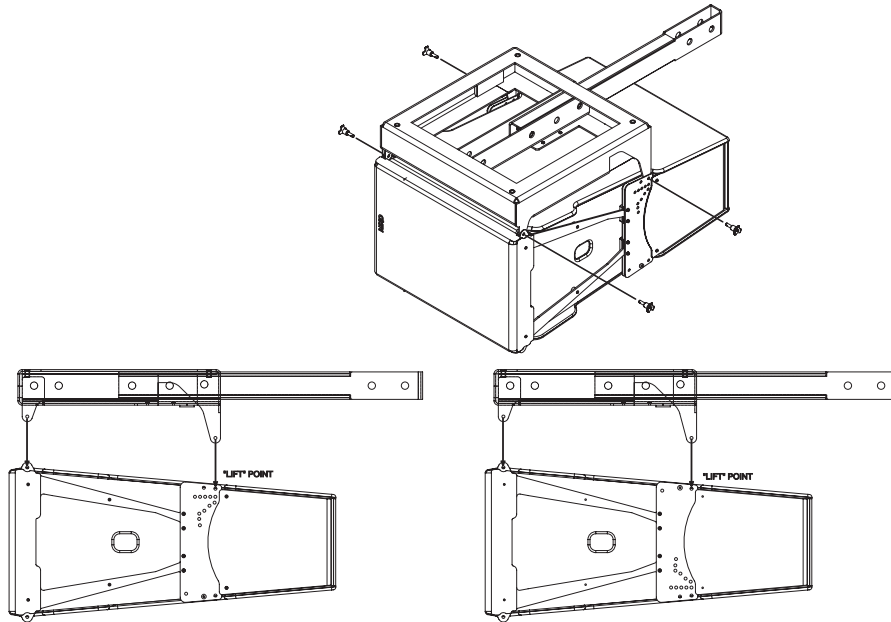

FIRST GEO SUB TO BUMPER ASSEMBLY

"LEFT" CONFIGURATION

"RIGHT" CONFIGURATION

5.7.3 First to second GEO SUB

4 push-pins (BLGEOD, 10mm diameter x 20 mm length) connect first to second GEO SUB, 2 additional push pins-are required for angle adjustment.

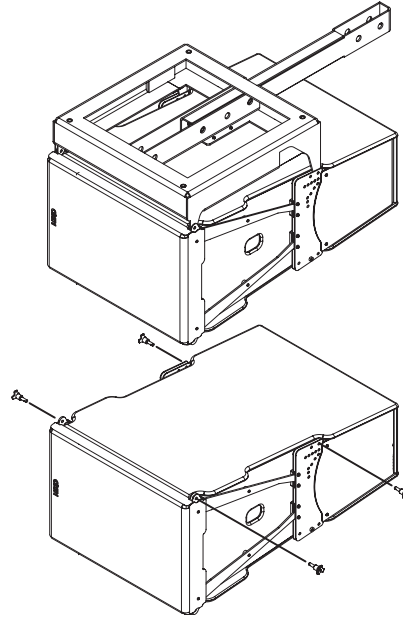

FIRST TO SECOND GEO SUB

- Lift bumper and top GEO SUB assembly, and position the next GEO SUB below the assembly, with NEXO logo on the same side than the upper cabinet.
- Lower bumper and top GEO SUB assembly carefully until the first and second GEO SUB side rigging plates locate. Use front grid, rear vent ports or handle to guide the assembly. The rigging plates have been designed to locate against each other and so align the holes correctly.
- Connect the upper GEO SUB link bar to the lower GEO SUB rigging plate (or lower link bar to upper rigging plate for “Right” configuration) by inserting one 10mm x 20 mm push-pin in the “SAFETY PIN MUST BE FITTED” hole on each side (see figure below).

IMPORTANT

The push-pins for “SAFETY PIN MUST BE FITTED” holes must always be inserted first and stay in position permanently. NEVER REMOVE THEM ONCE CABINETS ARE SUSPENDED.

- Insert two additional 10mm x 20mm push-pins in the front holes (see figure above).
- Lift the bumper and two first GEO SUB’s to a height that allows convenient access to the linking bars and the angle setting holes.
- Insert 1 additional push-pin to the required angle value hole on each side
- Check that all 6 push-pins are locked.

5.7.5 Applying compression with the Chain Lever Hoist

- Once the GEO SUB assembly is completed, connect the second GEO D Main Bumper below the last GEO SUB with the 10mm x 20mm push-pins inserted in the "FIX" bottom hole (see drawings below).
- Connect the Bottom Extension Bar EX3 to the Main Bumper through the Link Points with the two axes using corresponding holes (see drawing below), and ensure that these axes are properly locked with supplied "R" clips;
- Check the array according to the Checklist procedure described later in this manual.
- Attach the main hook of the Chain Lever Hoist to the rear of the Bottom Extension Bar EX3;

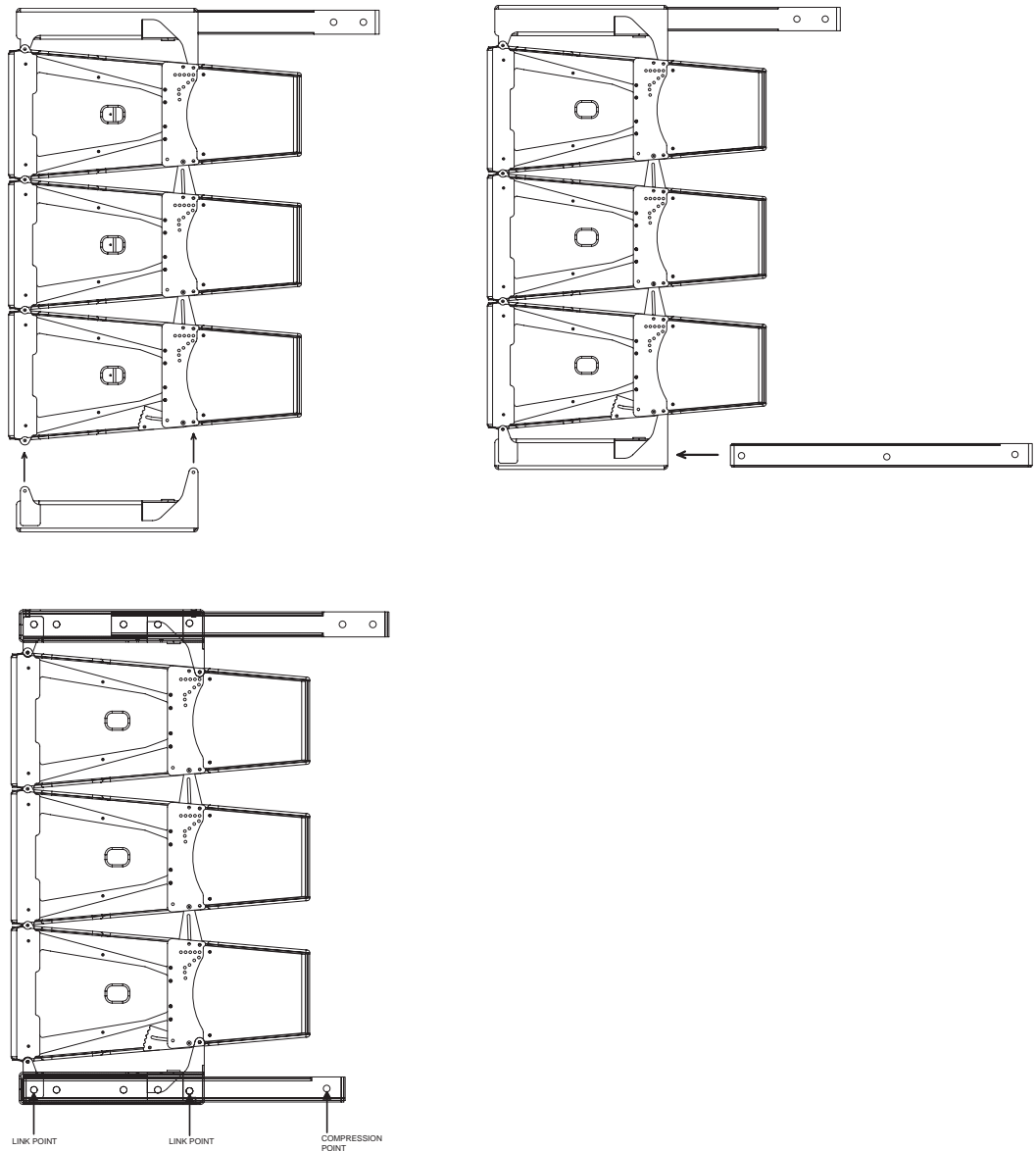

- Rotate the fingerwheel clockwise until the chain is taught;
- Make a final check that the Chain Lever Hoist is correctly installed;
- Rotate the lever to apply the pull-up force to the bottom of the array; notice that, as the chain gets shorter, the cabinets in the array close together to the angles set by the angle adjustments push-pins;

As the chainload tensions, ensure that no twisting occurs on the chain;

- When all of the cabinets are closed together, required force to rotate the lever becomes much stronger. This is the indication that the angles have been correctly set;
- store the surplus chain in the chain bag supplied. The chain bag should be clipped to the chain.

IMPORTANT

DO NOT attempt to force on LEVA750 or LEVA1500 lever once you feel it resisting strongly to rotation; you might damage GEO D flying system by doing so

IMPORTANT

DO NOT attempt to make any changes to the angle adjustments when the compression pull-up force is applied.

5.7.6 Positioning the cluster

- Lift the GEO SUB array to the height determined in GeoSoft (GeoSoft array height definition is for the top surface of the topmost cabinet);
- Adjust the bumper angle as determined in GeoSoft by lowering or lifting rear motor hoist (so that the front height does not change);
- Check all GEO SUB angles with an inclinometer;
- Once the bumper is in definitive position a secondary safety steel must be fitted (this secondary safety steel should link the bumper to a suitable point in the supporting structure);

IMPORTANT

The requirements for secondary safety systems vary with territories. However, the secondary safety steel MUST have a SWL equivalent to or greater than that of the rigging system.

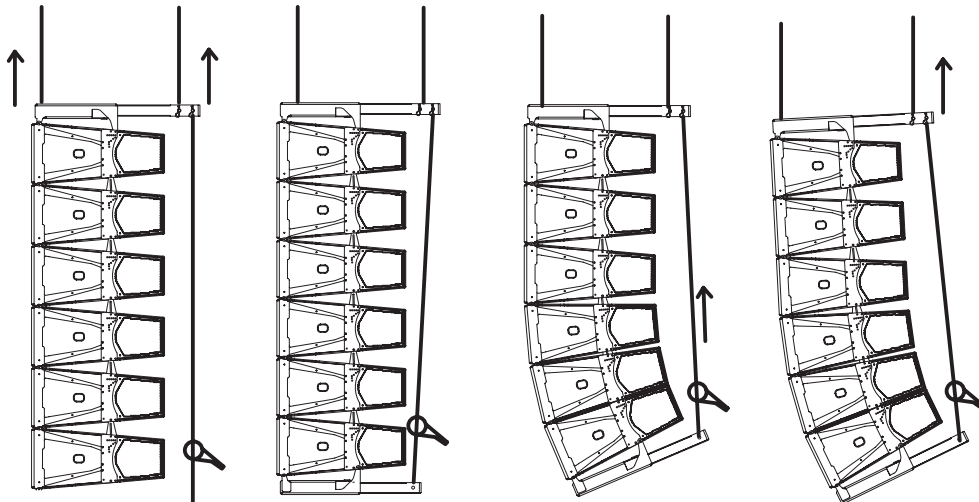

APPLYING COMPRESSION AND SETTING BUMPER ANGLE

5.7.7 De-rigging and loading out

Taking the system down is just a case of doing the reverse procedure to flying the array. However, there are some important factors to consider.

- Lower the array running the two motor hoists simultaneously until the bottom cabinet is just off the floor, main bumper being horizontal.
- Rotate the chain hoist lever counter-clockwise until there is no tension on the GEO SUB compression chain and no compression on the system.
- Disconnect the bottom GEO SUB from the second GEO D Bumper and remove the Bottom Extension Bar EX3.
- NB : As the system is lowered it is good practise to disconnect as many loudspeaker cables as can be reached without climbing the array. This ensures that a cable should not be accidentally forgotten when the system is separated. Damage to the connector will occur should this mistake be made.
- Angle adjustment push-pins should be removed from the angle setting and inserted in the "FIX" hole so that Geo SUB's sit flat on the dolly.
- Lift the dolly manually below the array and connect it to the bottom GEO SUB with 4 push-pins.

Carefully lower the array so that the dolly being on the ground is not being submitted to the entire cluster weight.

- Disconnect the first block of 2 GEO SUB's at the connection between 3rd and 4th bottom cabinets.
- Carefully lift the array using both motor hoists until the array is clear. Ensure the array is vertical at all times.
- Repeat the procedure for all cabinets.
- Remove the GEO D compression chain from the GEO D extension bar EX2, and remember to replace all the axes back in their respective beams.

5.8 Fixed installations

For fixed installation where GEOD / GEO SUB clusters are permanently in position and do not need to be removed, push-pins can be replaced with GEOD BNFIX kit.

Stacking or Rigging procedures are identical to the ones described above; however BNFIX nuts and bolts installation will be facilitated if front grill is removed.

- remove the front grill (drawings below);

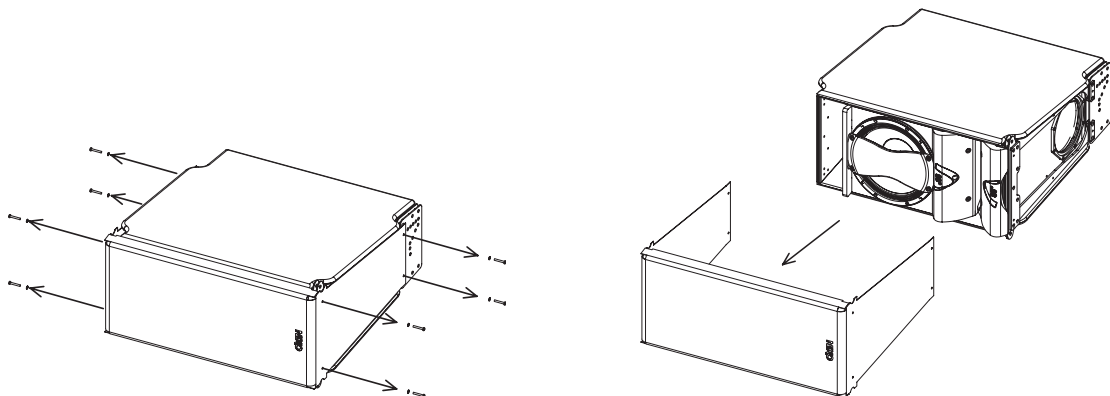

REMOVING THE GRILL

- place bolts and nuts according to drawing below

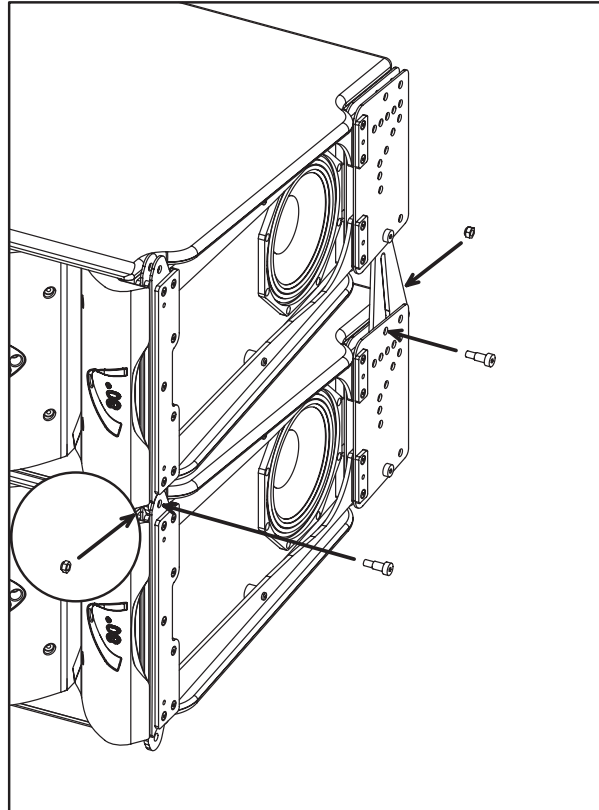

- re-install the grid, being careful that the NEXO logo must be on the GEO Waveguide side.

5.9 Testing and Maintenance of the system

- General: Geo is a precision piece of equipment and requires regular attention to maintenance in order to give long and reliable service. NEXO recommends regular testing of loudspeaker rigging components, preferably using a suitable test rig coupled with a visual inspection.
- Fasteners: there are several critical points in the GEO D – GEO SUB cabinets.

Of primary concern are:

- a) The grid screws attaching the grid to the cabinet
- b) The machine screws attaching the rigging system to the cabinet.
- c) The screws attaching the directivity flanges to the front of the cabinet.

These fasteners should be regularly checked and tightened as necessary.

- Cleaning: The exterior of the cabinet and the rigging system can be cleaned with a damp cloth soaked in mild soapy water. On no account use solvent based cleaners, which may damage the finish of the cabinet

After cleaning, the rigging system must be treated with a suitable lubricant to prevent rusting. NEXO recommends the use of Scottoil FS365 which is a water-based lubricant with a mixture of machine oil, surfactant and anti-rust treatment.

6 NEXO NX242 DIGITAL CONTROLLER FOR GEO D AND GEO SUB

IMPORTANT

GEO SUB and GEOD10 use latest NEXO proprietary sophisticated DSP algorithm, which require additional resources from the NX-Tension ES4 Card. All available GEO SUB and GEO D10 setups require that NX-ES4 card is installed in NX242 TD Controller.

6.1 NX242 Proprietary Functions

The NX242 is much more than a “generic” Digital Signal Processor. It provides all the standard functions that you expect from this type of unit, but its real value is the interface between you and your speaker system. The NX242 includes a number of proprietary functions, developed and refined during NEXO’s 20 years of loudspeaker development experience, to ensure that your PA delivers maximum performance and reliability.

6.1.1 Upgradable Firmware

NEXO releases regular firmware updates. Each new release is the result of our ongoing R&D program combined with user feedback from the field. New firmware releases can include new setups for different combinations of NEXO full range loudspeakers and subwoofers, improvements to existing setups, and new software functions. The NX242 is thus evolving with each of those releases, profiting from the latest discoveries of NEXO’s R&D department as well as the experience of NEXO users.

6.1.2 EQ & Filtering

Subsonic and VHF filtering

Low and high-pass filters are used to filter out frequencies that could possibly degrade the performance of the TDcontroller and amplifiers. The filters are optimised to work in conjunction with overall system response.

The high pass filters are also extremely important as they help control excursion at very low frequencies, which is a major feature for system reliability. This is one of the main reasons to avoid using setups which are not designed for the cabinet you are using.

Equalising acoustical response

NEXO loudspeakers are acoustically designed for maximum efficiency over their operating bandwidth. The NX242 provides the correction required to obtain a flat system response. Active rather than passive attenuation allows the lowering of amplifier voltages for a given output SPL and therefore increases the maximum SPL achievable with the same amplifier. Active equalisation can also extend a NEXO loudspeaker’s frequency response, especially at low frequencies where acoustical performance is limited by cabinet size.

While many DSP processors can provide this type of EQ, none can include the extensive measurement facilities and listening tests employed by NEXO R&D when adjusting NX242 setups for a particular loudspeaker.

Crossover section

Crossover between different bands is tuned for every set-up of every cabinet. The crossover is designed to ensure the best phase alignment possible throughout the crossover overlap region.

Each crossover is “made to measure” in order that each transducer can fit with its neighbour by achieving a perfect phase alignment. Unconventional filters are used, ranging from 6dB/octave to near infinite slopes depending of the type of crossover wanted. Time alignment is also performed in an unconventional way, by using the crossover filter group delays in combination with allpass and/or frequency dependent delays.

NX242 Digital TDcontroller Partial BLOCK DIAGRAM

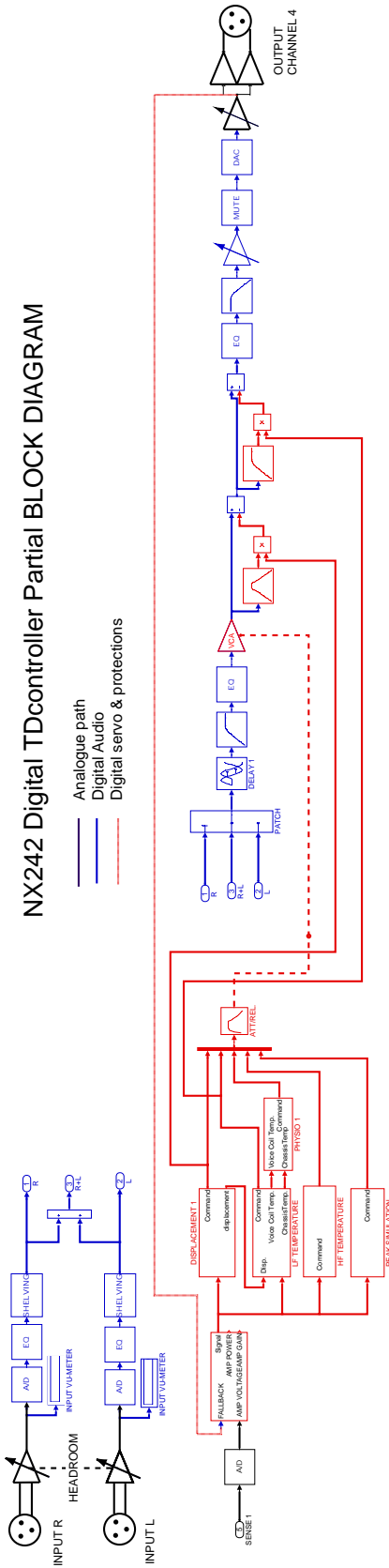

6.1.3 Protection

VCA's and VCEQ's

Each channel has its own simulation and protection process.

Each audio channel contains a combination of controlled gain stages (let's call them VCAs as in analogue circuitry). These VCAs are embedded into complex composite signal chains that adapt change their basic operation into frequency selective attenuation, similar to an analog voltage controlled dynamic equaliser (VCEQ).

Each VCEQ and VCA is controlled via synthesis of several signals from the various detection sections. That synthesis is in fact the envelope of those signals, with an optimised release and attack time for each VCEQ and VCA (depending on its frequency range and the cabinet selected).

Displacement Control

The Sense input signal is sent to a shaping filter producing a signal whose instantaneous amplitude is proportional to the voice coil excursion. This signal, after rectification, is compared to a preset threshold matching the maximum usable value, as determined from laboratory measurements. Any part of the signal exceeding the threshold is sent to the VCEQ control buffer while the VCEQ acts as an instantaneous (very short attack time) limiter to prevent displacement from exceeding the maximum permissible value.

Temperature Control

Each sense signal is fed into a shaping filter (one per transducer), each one producing a signal proportional to the instantaneous current flowing into the voice coil of the transducer. After rectification, this signal is integrated with attack and release time constants equivalent to the thermal time constants of the voice coil and chassis, producing a voltage, which is representative of the instantaneous temperature of the voice coil.

When this voltage reaches the threshold value corresponding to the driver's maximum safe operating temperature, the VCA becomes active to reduce the NX242's output signal level until the effective temperature falls below the maximum usable value.

In order to avoid detrimental effects induced by very long release time constants produced by the temperature detection signal (system output being reduced for an extended period, "pumping" effects, etc.), the detection signal is modulated by another voltage integrated with faster time constants that match the subjective perception of sound level. This allows the controller to reduce the effective operating duration of the temperature limiter and make it sound more natural, while the efficiency of protection is fully preserved and protection thresholds are kept as high as possible.

Physiologic Dynamic Control

The Physiologic Dynamic Control is intended to avoid unwanted effects produced by long attack time constants. By anticipating the operation of the temperature limiter, it prevents a high level audio signal appearing suddenly, then being kept up for long enough to trigger the temperature limiter. Without this, a rough and delayed gain variation would result that would be quite noticeable and unnatural.

The Physio control voltage acts independently on the VCA with its operation threshold slightly (3 dB) above that of the temperature limiter and a low compression ratio; its optimised attack time constant allows it to start operating without any subjectively unpleasant transient effects.

Peak Limiter

The peak limiter primary function is to avoid massive clipping of the amplifier, which can have some very audible artefacts and in some cases may be damaging to the loudspeakers. Modulation of the amplifier's supply voltage rails can create very low frequencies or high-frequency, high level harmonics. Since these occur after the NX242 in the signal path, they are not filtered by the TDcontroller circuitry.

The threshold of the peak limiter is set by the user to match the amplifier's clipping point.

The second function of the peak limiter is to avoid huge amounts of power being sent to a driver. Each driver is protected against overheating and overexcursion, but there could be other failure modes that cannot be predicted by simulation (especially mechanical damage to the cone). Each driver is specified for a certain power handling and a factory set peak limiter threshold is tuned to avoid any abuse.

6.2 Cardioid LF and VLF

Cardioid LF and VLF is one of the key advances of the GEO D / GEO SUB system. This feature is only achievable with a total control of the DSP chain. Although the basic concept as presented in audio text books is relatively simple, producing a cardioid pattern from a loudspeaker without a major loss of efficiency requires advanced DSP processing.

Other "loudspeaker management" DSP devices do not provide the algorithms that the NX242 uses to optimise the cardioid operation of the GEO D10 and GEO SUB.

GEO D10 LF and GEO SUB dispersion are digitally set to a cardioid pattern by adjusting the front and rear loudspeakers phase and amplitude relationship. Average rear to front attenuation is more than 12 dB.

6.3 GEO D NX242 Setups description

6.3.1 GEO D10 Passive Mode (Stereo Setups)

Hardware configuration

- Input can be selected in the MENU 3.2 (L, R or L+R);
- Output 1 drives left GEO D side-firing LF 8 inch neodymium transducers;
- Output 2 drives left GEO D front-firing LF/MF 12 inch neodymium transducers and the HF 3-inch voice coil, 1.4 inch exit compression driver;
- Output 3 drives right GEO D side-firing LF 8 inch neodymium transducers;
- Output 4 drives right GEO D front-firing LF/MF 12 inch neodymium transducers and the HF 3-inch voice coil, 1.4 inch exit compression driver.

6.3.2 GEO D10 Active Mode (Mono Setups)

Hardware configuration

- Input can be selected in the MENU 3.2 (L, R or L+R)
- Output 1 drives GEO D side-firing LF 8 inch neodymium transducers;
- Output 2 drives GEO D front-firing LF/MF 12 inch neodymium transducer;
- Output 3 drives GEO D HF 3-inch voice coil, 1.4 inch exit compression driver;
- Output 4 is not used.

6.3.3 GEO SUB (Stereo Setups)

Hardware configuration

- Input (L, R or L+R) can be selected in MENU 3.2
- Output 1 drives left GEO SUB side-firing 12 inch transducers;
- Output 2 drives left GEO SUB 18 inch transducer;
- Output 3 drives right GEO SUB side-firing 12 inch transducers;
- Output 4 drives right GEO SUB front 18 inch transducer.

6.3.4 GEO SUB & GEO D Passive (Mono Setups)

Hardware configuration

- Input (L, R or L+R) can be selected in MENU 3.2
- Output 1 drives GEO SUB side-firing 12 inch transducers;
- Output 2 drives GEO SUB front 18 inch transducer;
- Output 3 drives GEO D side-firing LF 8 inch neodymium transducers;
- Output 4 drives GEO D front-firing LF/MF 12 inch neodymium transducers and the HF 3-inch voice coil, 1.4 inch exit compression driver.

6.3.5 GEO SUB & GEO D Setups

Typical setup families are:

- **GEOD WIDEBAND:** GEOD starts at 55 Hz. This setup family is recommended for applications which are not VLF demanding;
- **GEO SUB & GEO D X-OVER:** GEO SUB is low-passed at 75 Hz and GEO D is high-passed at 75 Hz. This setup family is recommended when GEO SUB's are stacked and GEO D flown, and distance between them exceeds 2 meters (6 feet).
- **GEO SUB & GEO D OVERLAP:** GEO SUB is low-passed at 300 Hz and GEOD is high-passed at 75 Hz. Therefore, they "overlap" from 75 Hz to 300 Hz. This setup family requires proper phase alignment between systems up to 300 Hz, and is therefore is recommended when GEO SUB's and GEO D are flown together, or when distance between them is lower than 2 meters (6 feet).

Please be aware that setups are periodically revised, refer to the latest versions of the NX242 user manual and firmware (www.nexo-sa.com).

6.4 Trouble shooting

The NX242 has been designed to be user-friendly. However with highly technical systems such as GEO D & GEO SUB, incorrect adjustment of the NX242 can lower the quality & safety of your system. Listed below are the most common errors encountered by NEXO Technical Support.

6.4.1 Operation of Multiple TDcontrollers

Typically, GEO D / GEO SUB systems require multiple NX242's per side. Eventually, two or more NX242's will operate within the same cluster. It is mandatory to verify the consistency of the setups and adjustment between processors to avoid the problems described below.

IMPORTANT

When using multiple NX242's in a single array, all parameters should be identical and set to proper values.

6.4.2 Amplifier Power (MENU 2.7)

If the amplifier power (MENU 2.7) is set to a value below the amplifier's actual power, the peak limiter of the NX242 will trigger continually, creating audible distortion. Please note that this peak limiter is not set to act as a compressor on the signal. It is intended to minimize the clipping of the amplifier by operating slightly after the amplifier's clipping point.

One way to properly adjust this parameter is to set amplifier power at maximum (5000W) and decrease the value until the amplifier and TDcontroller clip at the same time.

6.4.3 Amplifier Gain (MENU 2.6)

It is very important to check the gain of each channel. These values should be set in agreement with amplifier gain. The second line of the MENU2.6 displays the gain as seen by the NX242 to ease the setting of this parameter.

6.4.4 Gains

If your amplifier gains are not the same on each channel, you will have to adjust the inter-channel gain in order to compensate for this amplifier gain difference.

6.4.5 Delays

Multiple NX242's can be used on a single GEO D array. When changing the delay in one NX242 TDcontroller that is part of a multi-controller system, take great care to have exactly the same delay setting in all NX242 TDcontrollers that receive the same input signal (i.e. all NX242's that are fed from the Left output of the mixing console should have the same delay settings). A Tangent Array is very sensitive to delay differences between sections of the array in the same line. You could experience coverage problems if all delays applied to a Tangent Array are not equal.

Please refer to the chapter in the NX242 User Manual on setting delay for proper time alignment between GEO D's and GEO SUB's.

6.4.6 Reversed Cardioid Pattern

Polarity checks are often performed while the system is being set up. Keep in mind that cardioid speakers may also require a coverage test. If you invert two outputs of the NX242, you could have the main lobe inverted and firing to the rear. It may be quite hard to detect a reversed cardioid pattern when it involves one section of a large array.

A good practice is to test the each cabinet in the array with the front speakers only. The system is then omni-directional. Then turn on the back speaker: you should notice a massive reduction at the back, and additional level at the front.

This test must be done in addition to the usual polarity test.

6.4.7 Using the wrong NX242 setups for a given cabinet

Each NX242 setup is tailored for a certain NEXO loudspeaker. Using the wrong setup will create safety and quality problems. Always check that every cabinet in your system is being driven by the correct NX242 setup.

6.4.8 Connections

To ensure correct electronic behaviour, and to guarantee specifications and EMC performance, a NX242 must be properly wired. Always use balanced connectors with the shield connected to pin 1 on both sides. For more wiring recommendations please refer to the application note in the NX242 manual update.

7 SYSTEM ALIGNMENT GUIDELINES

The NX242's factory delay presets are optimised to provide the best possible crossover between the GEO D and GEO SUB systems. The reference point for this adjustment is the front of each cabinet. (This means that the internal delays needed to achieve a correct time alignment are set for cabinets standing next to each other with both fronts aligned). We recommend that the system is adjusted so that arrivals from GEO D and GEO SUB are coincident at a fairly distant listening position.

7.1 GEO SUB – GEO D Cluster design

Cluster design must be done with Geosoft2, which provides very intuitive and fast method to determine all cluster geometry parameters in relation to venue where cluster is implemented.

IMPORTANT

Geosoft2 is a freeware downloadable on www.nexo-sa.com. Please check our website periodically for upgrades.

Never install a GEO D / GEO SUB cluster without checking its acoustical performances and mechanical safety in Geosoft2 prior to installation.

Please contact your local distributor for assistance and/or training on Geosoft2

7.2 Stacked GEO SUB's and Flown GEO D's

Recommended NX242 GEOD setup family: X-OVER

In the example below, r_1 being the distance from GEO D array to listener position, and r_2 being the distance from GEO SUB to listener position, the distance difference is then $r_1 - r_2$ (specified meters or feet).

- $r_1 > r_2$, the delay should be set on the GEO SUB NX242 TDcontroller.
- $r_1 < r_2$, the delay should be set on the GEO D NX242 TDcontroller
- To convert the result in time delay (specified in seconds), apply:

$$\Delta t = (r_1 - r_2) / C \quad r_1 \text{ and } r_2 \text{ in meters, } C \text{ (sound speed)} \approx 343 \text{ m/S.}$$

The delay parameter is set in MENU 1.2 (set the units to meters, feet or seconds according to your preference). Delay will have to be adjusted according to the distance difference $r_1 - r_2$ (see figure below).

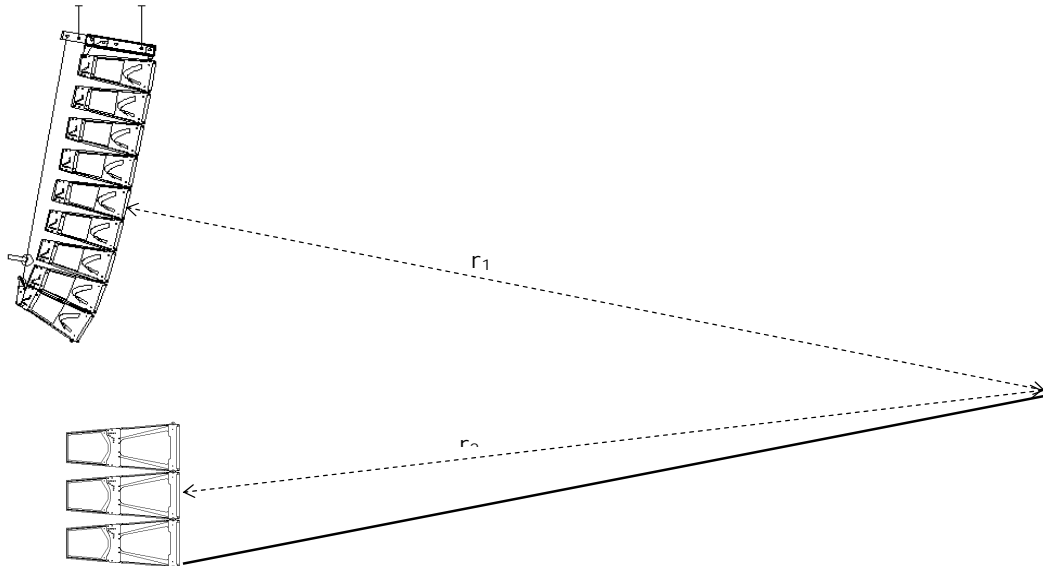

7.3 Flown or Stacked combined GEO SUB's and GEO D's clusters

Recommended NX242 setup family: OVERLAP

When GEO SUB's are flown or stacked within the GEO D array, GEO SUB delay should be set at the same value than GEO D's, ie there should be no delay difference between systems.

7.4 Separate GEO SUB and GEO D clusters

Delay must be set to compensate for horizontal distance offset between front edges.

When GEO SUB's and GEO D's are flown in separate clusters, distance between clusters should be:

NX242 GEOD setup family: OVERLAP

- 1.25m (4 ft) minimum center to center or 50cm (1.5 ft) side to side;
- 1.75m (6 ft) maximum center to center or 1m (3 ft) side to side.

NX242 GEOD setup family: X-OVER

- 1.25m (4 ft) minimum center to center or 50cm side to side;
- No upper limit.

7.5 Driving the GEO SUB's from the AUX send

It is quite common to use the AUX send of a mixing desk to drive the Sub section of a PA system. This gives the mixing engineer more flexibility to set the level of the subbass relative to the main PA, apply special effects, or to use a different EQ on the Sub. However, it also raises some serious issues for the performance & safety of the system (mostly time alignment).

At NEXO, great care is taken to design optimum phase alignment from one octave above to one octave below the crossover frequency point. By doing so, drivers are working perfectly together and providing the best efficiency possible. It is then up to the user to adjust the delay on the NX242 to match the physical path difference of the different systems. It is thus possible to get a well adjusted system, even without measuring instruments.

If GEO SUB's are driven from an AUX output, NX242 is fed with two signals coming from different sources. If those two sources (MAIN output & AUX send) are not exactly in phase, delay is introduced into the crossover between the GEO D array and the GEO SUB's. It is then mandatory to use proper measurement tool to optimize phase response.

Why is it unlikely that AUX and MAIN outputs have the same phase?

- Signal paths are likely to be different; any filter modifying the bandwidth and EQ of the signal is also affecting the phase.
Example: a 24dB/oct high pass filter set at 15Hz is affecting amplitude of the signal by only 0.6dB at 30Hz, but the phase shift is 90°!! At 100Hz we can still measure 25° of phase shift.
- Limiting bandwidth with a low pass filter can introduce a phase difference of up to 180° (completely out of phase) at the cross over point.
- If the signal is passing through any digital equipment, between 1.4ms and 2.2ms is being added (around 70° phase shift at 100Hz) due solely to the converter delay! The additional delay due to the processing itself (look ahead compressor, delay...) can be quite important as well.

If both outputs are not measured in the actual configuration, it is very likely that phase alignment will not be correct.

Consequences of badly aligned systems

Mis-aligned systems have lower efficiency: i. e. for the same SPL the system will have to be driven harder, activating the displacement & temperature protection at lower output levels. Both sound quality and reliability will decrease as the system is stressed.

Precautions & Checks

Before using the AUX of a mixing desk, ensure that MAIN and AUX outputs are in phase;

Always apply identical EQ or processing on both channels, so that the phase relationship will not be altered;

Never add additional low pass filtering on the SUB or high pass filtering on the main system;

Inverting polarity on one channel should always result in a massive difference near the crossover point. If that is not the case, the system is no longer aligned.

7.6 Recommended installation tools and equipment

- Tape measure – should be 30m/100ft in length and be of durable fibre material. Have one per array available to speed up the installation process.
- Laser Inclinator – For measuring vertical and horizontal angles in the venue. An ideal product is the Calpac 'Laser projecting a dot' version which costs approximately 60 €
- Digital remote inclinometer – with a remote sensor in the bumper and a meter unit at ground level to ensure precise installation of the cluster. NEXO GeoSight system predicts the stationary angle of the array, even while it is swinging, and has a green laser mounted coincident to and parallel with the axis of the topmost cabinet.
- Spirit level – used to ascertain the trueness of the surface from which the angle measurements originate.
- Rangefinder measuring device – either a Disto type laser measure or an optical laser rangefinder can be used. Devices such as the Bushnell 'Yardage Pro' sports rangefinders provide sufficiently accuracy and are easy to use. They have the additional advantage of working very well in bright sunlight.
- Electronic calculator with trigonometric functions to calculate the height from ground level to points in the room. The formula to calculate height of a point from measured angle and distance is:
- Height of point = $\text{Sin}(\text{vertical angle in degrees}) \times \text{distance to point}$
- NB: Take care when using spreadsheets as they calculate using radians by default. To convert degrees to radians use the formula:
- Angle (in radians) = $3.142 \times \text{Angle (in degrees)} / 180$
- Computer – Laptop or Desktop PC running Windows 2000 or XP with the current version of NEXO GeoSoft2 installed. It is not possible to configure a Geo tangent array properly without using GeoSoft2. Note that, when GeoSoft2 designs are prepared prior to arrival at the venue, it is often necessary to modify or update the design to accommodate special circumstances. A PC is absolutely essential to make such changes.
- Audio Analysis Software – recommended but not absolutely essential, programs such as SIA Smaart Pro, Spectralab or Spectrafoo enable rapid and detailed analysis of the installation. Consider taking a training course in using one of these tools if you are not already competent with them – it will pay dividends in increased performance of the system.

8 GEO D – GEO SUB ARRAY SYSTEM CHECK LIST

It is essential to execute all these check steps prior to perform a sound check on the “front end” to the system. Following this checklist step by step will prevent many troubles and will save time in the end.

8.1 Are the NX242 Digital TDcontrollers properly configured?

IMPORTANT

If you must change any of the parameters listed above, make sure that you use the same values on all NX242's.

8.1.1 NX242 settings

Output Assignment

NX Setup / NXChannel	1	2	3	4
GEO SUB – GEO D Passive Mono	GEO SUB Rear	GEO SUB Front	GEO D Rear	GEO D Front
GEO SUB - Stereo	GEO SUB Rear	GEO SUB Front	GEO SUB Rear	GEO SUB Front
GEO D Passive Stereo	GEO D Rear	GEO D Front	GEO D Rear	GEO D Front
GEO D Active	GEO D Rear LF	GEO D Front LF/MF	GEO D Front HF	-

Output parameters

Output Label	Amp Gain (1)	Amp Power (1)	Global Gain (2)	Global Delay (2)	Sense Gain	Speaker Qty (3)	Headrom (4)
All channels (GEO D and GEO SUB)	26 dB	1600 W/8Ω	0 dB	0 ms	0 dB		5 bars

(1) values for recommended amplifier gain and power : should be set in agreement with selected amplifiers specifications

(2) Local gain and delay values are inter-locked channel 1&2 and 3&4

(3) Should be in agreement with implemented cluster; acts on a shelving filter designed to compensate for LF coupling (6 GEOD is 0dB gain on shelving filter, less than 6 is positive gain, more than 6 is negative gain)

(4) Disabled when using digital inputs.

8.2 Are the amplifiers properly configured?

Freq. Band	Mode	Gain Switch	Limiter	High Pass
All channels (GEO D and GEO SUB)	Stereo	26 dB	None	None

8.3 Are the amps and the NX properly connected?

Check that the sense lines on the NX242's are properly connected by applying a signal to the corresponding output and verify that the correct Sense LED illuminates.

8.4 Are the speakers properly connected and angled ?

- Attach the first serie of modules to the bumper.
- Before flying, verify that all channels of all modules are functioning properly.
- Make sure that each GEO D10 / GEO SUB is producing the proper front/rear summation: when listening from behind the array, switch the front drivers in and out. You should hear a reduction in the LF range when the both front and rear drivers are on as compared to when the rear drivers

only are on. When listening from the front, you should hear a strong increase in the LF range when connecting the rear drivers.

- To check that all front elements have the proper amplitude and phase, you should listen to the upper boxes at a close distance (<1 meter). You should be able to move from the top to the bottom of the cluster without hearing any change in the tonal balance.
- Verify that the angle settings are the same on both sides of each module.
- Raise the bumper, attach the next serie of modules and repeat the above checks.
- Make sure that these serie of modules sum properly with the modules above them.
- When all the modules are flown, check that the aiming angles are the same left and right.
- Make sure that multiple GEO D's and GEO SUB's are summing properly: 6 dB gain per doubling of quantity.

8.5 Final Pre-Sound Check Check

Play a CD track mono left, and then right : both sides must sound strictly identical. When listening in the center between two GEOD / GEO SUB's, everything from LF to HF should be located to the "phantom center" position. If not, repeat the above check sequence to identify the source of the problem.

9 TECHNICAL SPECIFICATIONS

9.1 GEO D10 Vertical Tangent Array Module

9.1.1 System specifications

PRODUCT FEATURES		GEO D10
Components		HF: 1 x 3" voice coil, 1.4" throat 16 Ohms driver on a 5° hyperboloid reflective wavesource. MF/LF (front-firing): 1 x 12" (30cm) high excursion neodymium 16 Ohm driver. LF (side-firing): 2 x 8" (20cm) neodymium 8 Ohm drivers in series.
Height x Width x Depth		380 x 744 x 750 mm (15" x 29 ^{1/2"} x 29 ^{1/2"}) including array assembly system Rigging axis to axis height: 344mm (13 ^{5/16"})
Shape		10° Trapezoid.
Weight: net		57 kg (125.7 lbs) including array assembly system.
Connectors		1 x AMPHENOL EP6 6 pole socket In; 1 x AMPHENOL AP6 6 pole connector Through.
Construction		Baltic birch ply with structured black coating.
Front finish		Molded Dark Grey Metal Grill.
Flying points		Integral flying system. Intercabinet angle adjustments = 0.2°, 0.315°, 0.5°, 0.8°, 1.25°, 2.0°, 3.15°, 5°, 6.3°, 8.0°, 10.0° (logarithmic steps)
SYSTEM SPECIFICATIONS		GEO D10 with NX242 TDcontroller & NX-tension Card
Frequency response [a]		60 Hz – 19 kHz ± 3 dB
Usable range @-6dB [a]		55 Hz – 20 kHz
Sensitivity 1W @ 1m [b]		105 dB SPL nominal (103 dB SPL wideband)
Peak SPL @ 1m [b]		Configuration dependent [d].
Dispersion [c]		Vertical plane: Configuration dependent [d]. Horizontal plane: Configurable 80° / 120°. Low Frequency: cardioid
Crossover frequencies		LF-MF: 300 Hz active; MF-HF: 1.1 kHz Passive or Active (internally configurable)
Nominal impedance		HF: 16 Ohm; LF/MF front: 16 Ohm; LF rear: 16 Ohm
Recommended amplifiers		HF: 875 to 1550 Watts into 4 Ohms MF/LF front: 1750 to 3100 Watts into 4 Ohms LF rear section: 1750 to 3100 Watts into 4 Ohms
3 GEO D10 in Parallel		
4 GEO D10 in parallel		HF: 1000 to 1800 Watts into 4 Ohms MF/LF front: 2000 to 3600 Watts into 4 Ohms LF rear section: 2000 to 3600 Watts into 4 Ohms
6 GEO D10 in parallel		HF: 1650 to 3000 Watts into 2 Ohms MF/LF front: 3300 to 6000 Watts into 2 Ohms LF rear section: 3300 to 6000 Watts into 2 Ohms
SYSTEM OPERATION		
Electronic controller		The NX242 Digital TDcontroller (with NX-Tension Card) presets are precisely matched to the GEO D Series cabinets and include sophisticated protection systems as well as advanced cardioid directivity DSP algorithms. Using GEO D Series cabinets without a properly connected NX242 & NX-Tension Card will result in poor sound quality and can damage components.
Array design		Arrays of less than 3 x GEO D10 will provide poor dispersion control and are neither recommended nor supported.
Sub-bass		GEO SUB directional sub extends system low frequency response down to 35 Hz
Speaker cables		Active: 5(-) / 6(+): HF; 3(-) / 4(+): LF/MF Front ; 1(-) / 2(+): LF Rear. Passive: 5(-) / 6(+): Not Connected; 3(-) / 4(+): LF/MF/HF Front ; 1(-) / 2(+): LF Rear..
Rigging System		Please refer to the GEO user manual before any operation.

As part of a policy of continual improvement, NEXO reserves the right to change specifications without notice.

[a] Response curves and data: anechoic far field above 200 Hz, half-space anechoic below 200 Hz.

[b] Sensitivity & peak SPL: will depend on spectral distribution. Measured with band limited pink noise.

[c] Refers to the specified +/- 3 dB range. Data are for speaker + processor + recommended amplifier combinations.

[d] Directivity curves and data: 1/3 octave smoothed frequency response, normalized to on-axis response. Data obtained by computer processing of off-axis response curves.

[e] Please refer to the GEO D user Manual.

Usable range data: frequency response capability with TD crossover slopes removed.

9.1.2 GEO D10 Dimensions

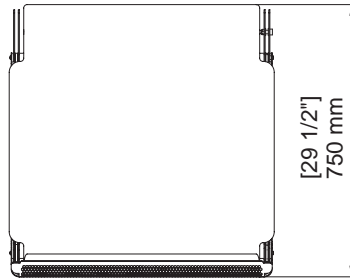
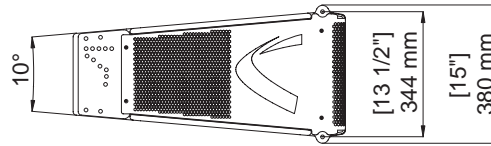
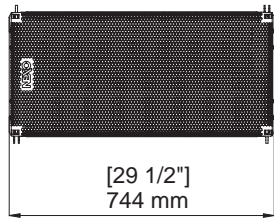

9.1.3 GEO D10 Diagrams

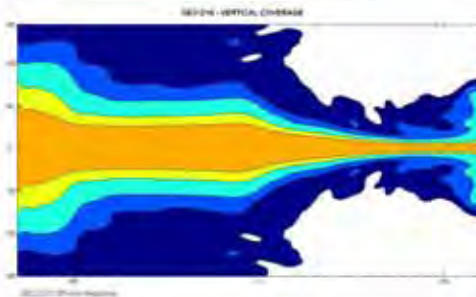
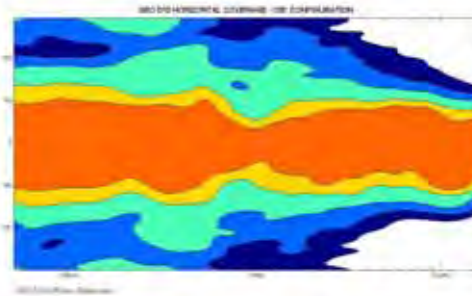
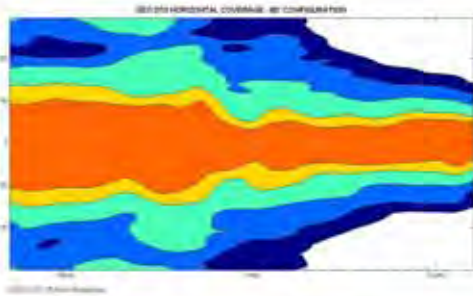
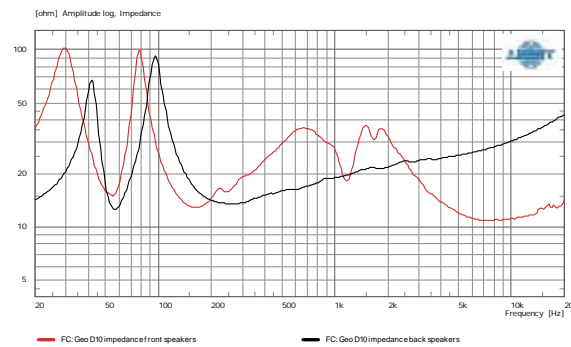
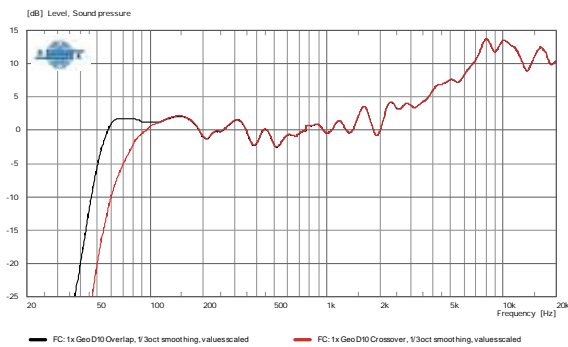

9.2 GEO SUB Directional Sub-Bass

9.2.1 System specifications

PRODUCT FEATURES		GEO SUB
Components		1 x 18" (46cm) long excursion neodymium 8 Ohm drivers & 2 x 12" (30cm) neodymium drivers
Height x Width x Depth		515 x 744 x 1131 mm (20 1/2" x 29 1/2" x 44 1/2")
Shape		10° Trapezoidal
Weight: Net		86 kg (189.6 lbs)
Connectors		2 x NL4MP SPEAKON 4 pole (In & Through)
Construction		Baltic birch ply finish with structured black coating.
Front finish		Molded Dark Grey Metal Grill.
Flying points		Integral flying system. Intercabinet angle adjustments = 0.2°, 0.315°, 0.5°, 0.8°; 1.25°, 2.0°, 3.15°, 5°, 6.3°, 8.0°, 10.0° (logarithmic steps)
SYSTEM SPECIFICATIONS		GEO SUB with NX242 TDcontroller
Frequency Response @-3dB [a]		38 Hz – 300 Hz
Usable Range @-6dB [a]		35 Hz – 500 Hz
Sensitivity 1W @ 1m [b]		103 dB SPL Nominal
Peak SPL @ 1m [b]		140-143 dB Peak
Dispersion [c]		Cardioid pattern over the entire useable bandwidth (two channels of the NX242 are used for the process).
Directivity Index [c]		Q = 3.4 & DI = 5.3 dB over the entire useable bandwidth.
Crossover Frequency		X-Over Mode = 75 Hz active / Overlap Mode = 300 Hz through NX242 Digital TDcontroller.
Nominal Impedance		2 x 8 Ohms
Recommended Amplifiers		2 amplifier channels are required for directional operation, each rated at 1000 to 2000 Watts into 8 Ohm per channel.
SYSTEM OPERATION		
Electronic Controller		The NX242 Digital TDcontroller presets are precisely matched to the GEO SUB and include sophisticated protection systems. Using the CD18 subbass without a properly connected NX242 Digital TDcontroller will result in poor sound quality and can damage components.
Speaker Cables		The front loudspeaker of the GEO SUB is wired 2+ & 2- while the rear loudspeaker is wired 1- & 1+. The GEO SUB must use separate cables from the main system.
Rigging System [d]		Please refer to the user manual before any operation.

As part of a policy of continual improvement, NEXO reserves the right to change specifications without notice.

- [a] Response curves and data: anechoic far field above 400 Hz, half-space anechoic below 400 Hz.
Usable range data: frequency response capability with TD crossover slopes removed.
- [b] Sensitivity & peak SPL: will depend on spectral distribution. Measured with band limited pink noise.
Refers to the specified +/- 3 dB range. Data are for speaker + processor + recommended amplifier combinations.
- [c] Directivity curves and data: 1/3 octave smoothed frequency response, normalized to on-axis response. Data obtained by computer processing of off-axis response curves.
- [d] Please refer to the user manual.

9.2.2 GEO SUB dimensions

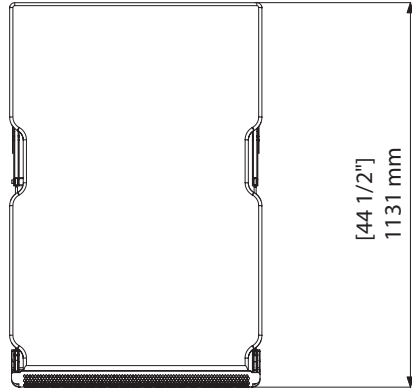
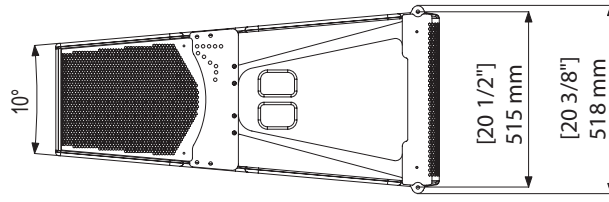
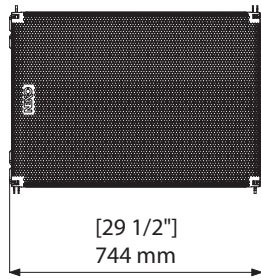

9.2.3 GEO SUB diagrams

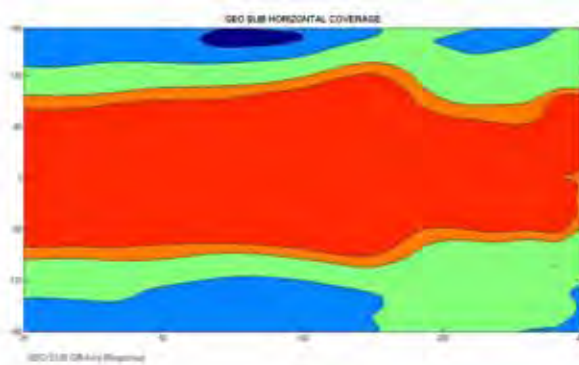
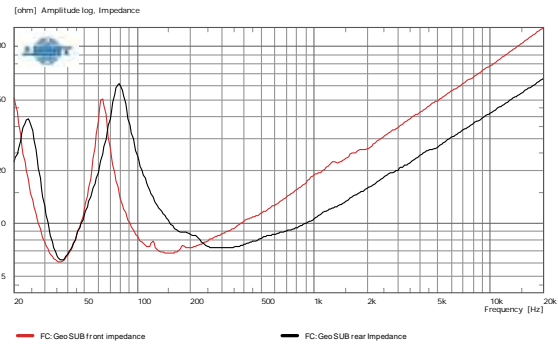
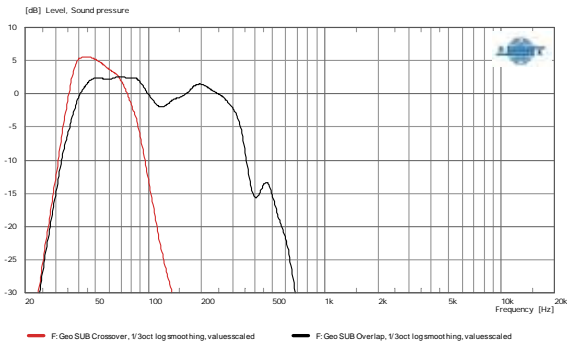

9.3 **GEO D / GEO SUB Rigging system**

9.3.1 **GEO D / GEO SUB Bumper**

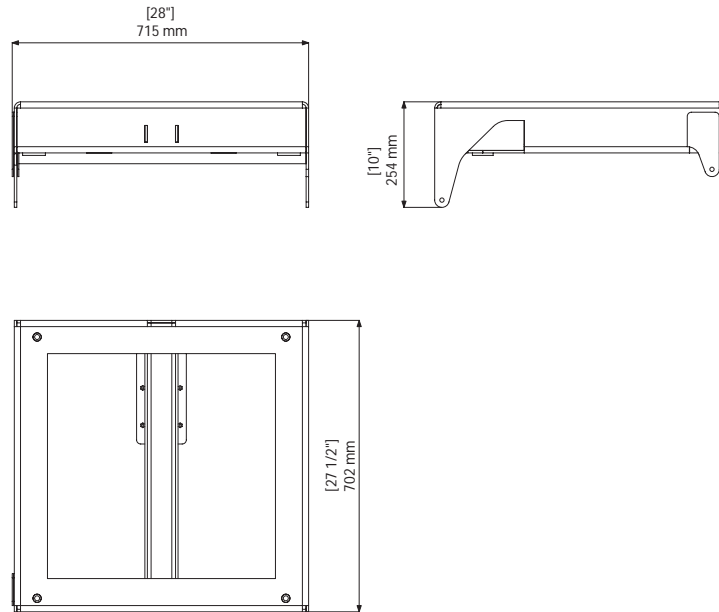

WEIGHT : 45 KG / 99.2 LBS

9.3.2 **GEO D Short Extension Bar EX1**

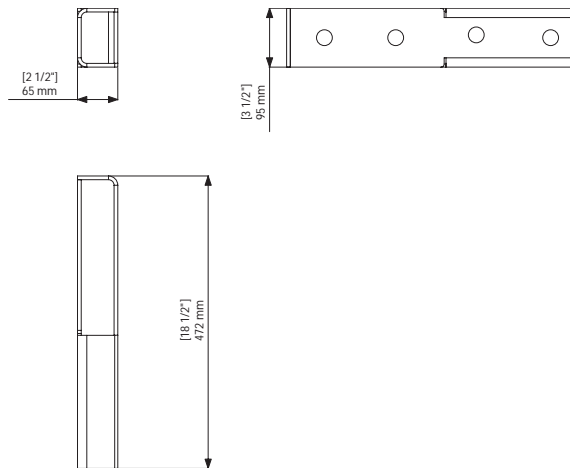

WEIGHT : 5.3 KG / 11.7 LBS

9.3.3

9.3.4 GEO D – ORP (Compression Wheel for EX1 Only)

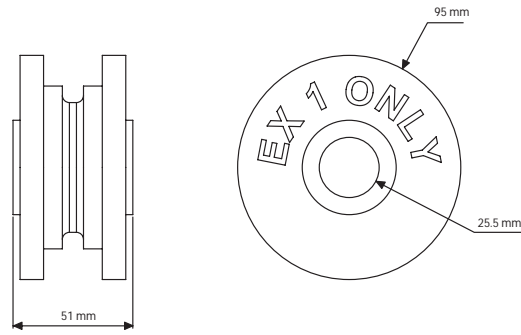

WEIGHT: 0.250KG / 0.55 LBS

9.3.5 GEO BRIDLE

WEIGHT: 3 KG / 6.6 LBS

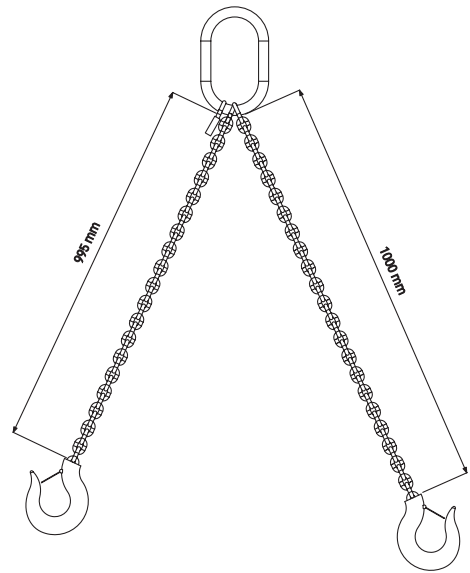

9.3.6 GEO D Long Extension Bar EX2

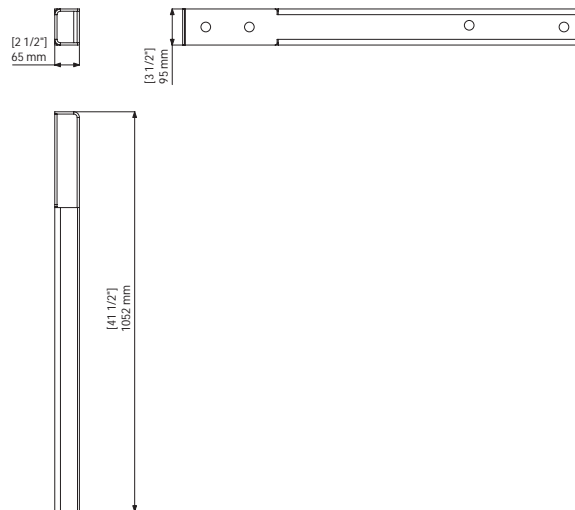

WEIGHT: 13.1 KG / 28.9 LBS

9.3.7 GEO SUB Bottom Extension Bar EX3

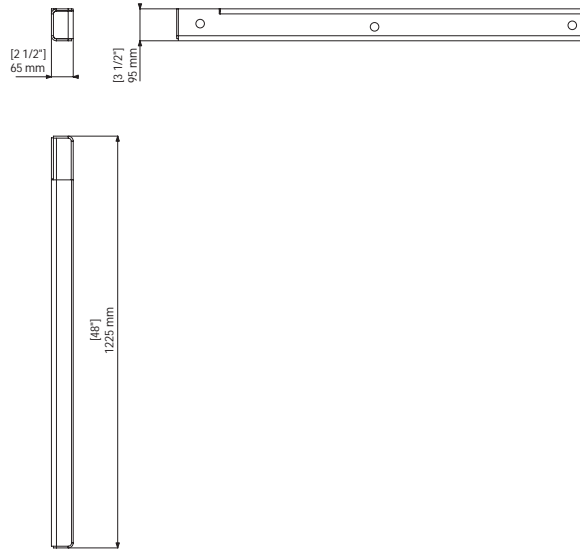

WEIGHT: 16.1 KG / 35.5 LBS

9.3.8 GEO D Front Extension Bar EX4

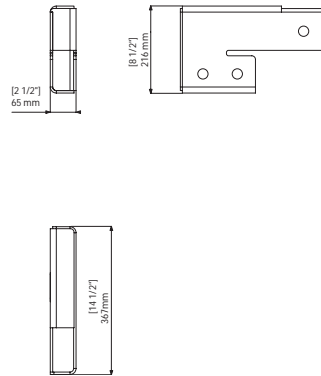

WEIGHT: 6.9 KG / 15.2 LBS

9.3.9 GEO D Bottom Bumper

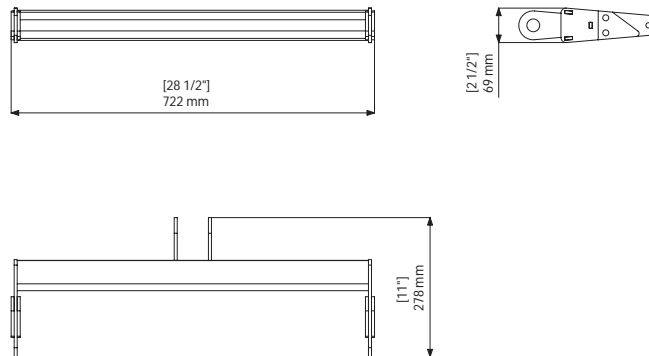

WEIGHT: 10.4 KG / 22.9 LBS

9.3.10 GEO D Chain Lever Hoists



MAX LOAD 750 KG / 1650 LBS
WEIGHT: 10.3 KG / 22.7 LBS
CHAIN LENGTH: 6 M / 16.7 FT



MAX LOAD 1500 KG / 3300 LBS
WEIGHT: 23.7 KG / 52.2 LBS
CHAIN LENGTH: 9M / 29.5 FT

9.3.11 GEO D / GEO SUB Push-Pins

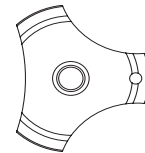
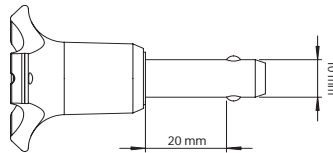
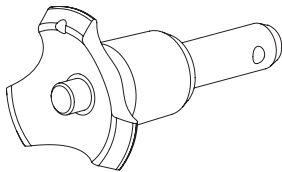

WEIGHT: 0.046 KG / 0.10 LBS

9.4 NX242 TDcontroller with NX-Tension Card

9.4.1 Specifications

SPECIFICATIONS	NX242 Digital TDcontroller
Output Level	+28 dBu Max. into 600 Ohm load
Dynamic Range	110 dBu
THD + Noise	< 0.002% flat setup (for output at 27.5dBu)
Latency time	1.7ms on a flat setup
Power Supply	90V-260V
FEATURES	
Audio Inputs	2 Audio Inputs 24 bit converters Electronically Balanced, 50k Ohm. 2 XLR-3F Connectors. 4 Digital Ethersound Inputs with NXTension ES4 Card
Sense Inputs	4 Amplifier Sense Inputs Floating 150 kΩ. 18 bit converters 8 Pole Removable Strip Terminal.
Audio Outputs	4 Audio Outputs. 24 bit converters Electronically balanced, 50 Ohm 4 XLR-3M connectors 4 Digital Ethersound Outputs with NXTension ES4 Card (enabled for compatible amplifiers only)
Processing	24 bit data with 48-bit accumulator. 200 MIPS
Front Panel	Menu A and Menu B buttons 16 characters by 2 lines display Select Wheel & Enter button (◀▶) IN Clip – DSP Clip red LED's Speaker Protection yellow LED for each channel Individual Mute/Solo buttons and red LED for each channel Amp. Sense & Peak (green & red) LED's for each channel
FLASH EPROM	Software updates/upgrades, new system setups, available on www.nexo-sa.com
Rear Panel	RS232 connector for serial com 2 x RJ45 connectors with NXTension ES4 Card 1 RJ45 + 2 RJ11 with NXTension CAI Card
Dimensions & Weight	1U 19" Rack - 230 mm (9") Depth. 4 kg

9.4.2 Front and Rear Panel view

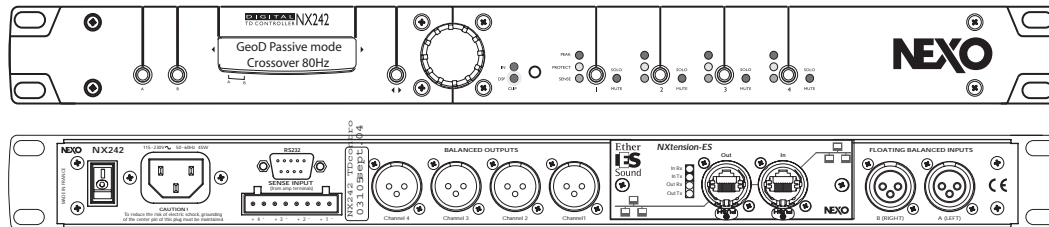

9.4.3 Block Diagram

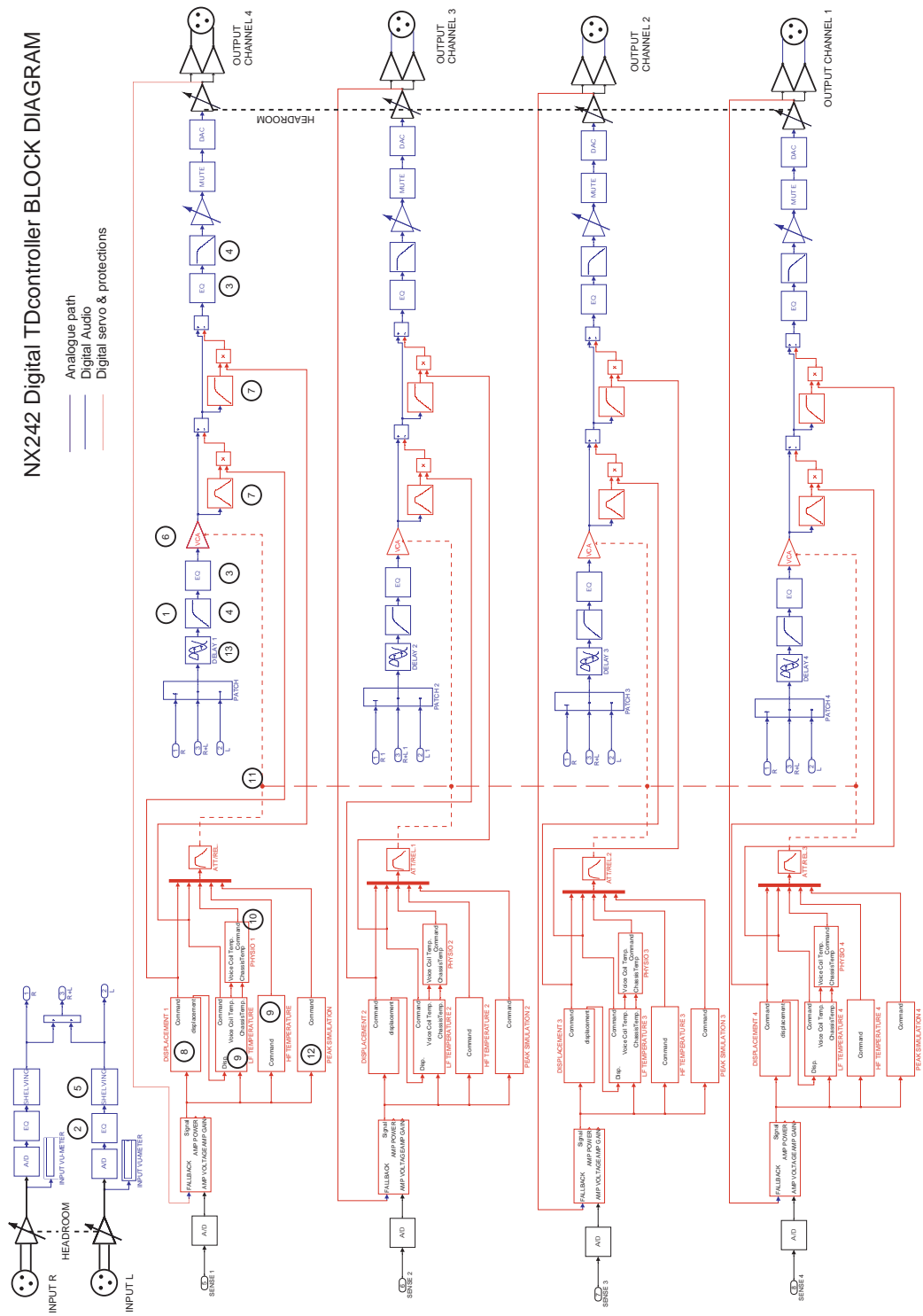

10 CONNECTION DIAGRAMS

10.1 GEO D cluster to amplifiers and NX242 (Stereo passive mode)

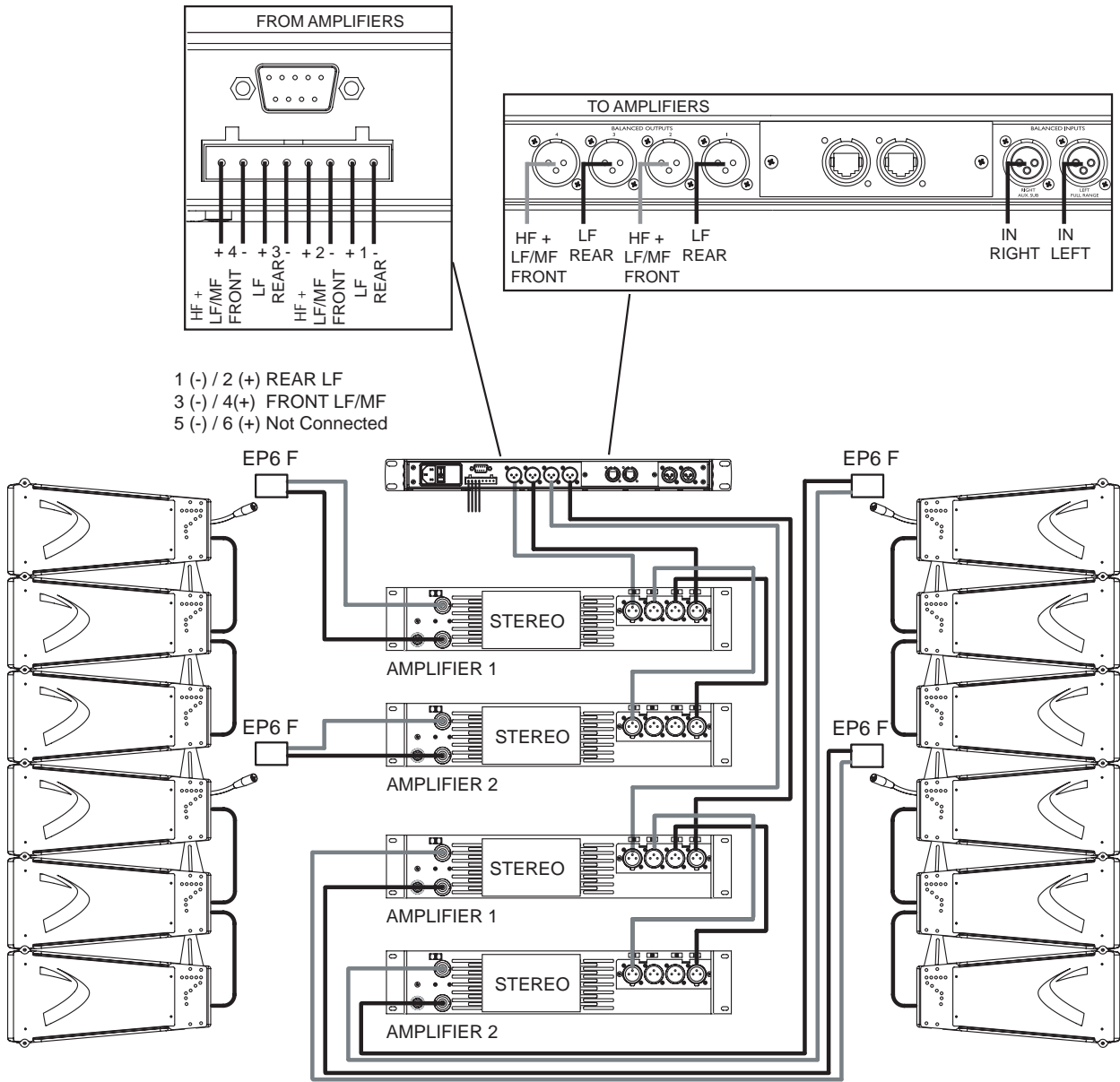

STEREO PASSIVE MODE

10.2 GEO D cluster to amplifiers and NX242 (Mono active mode)

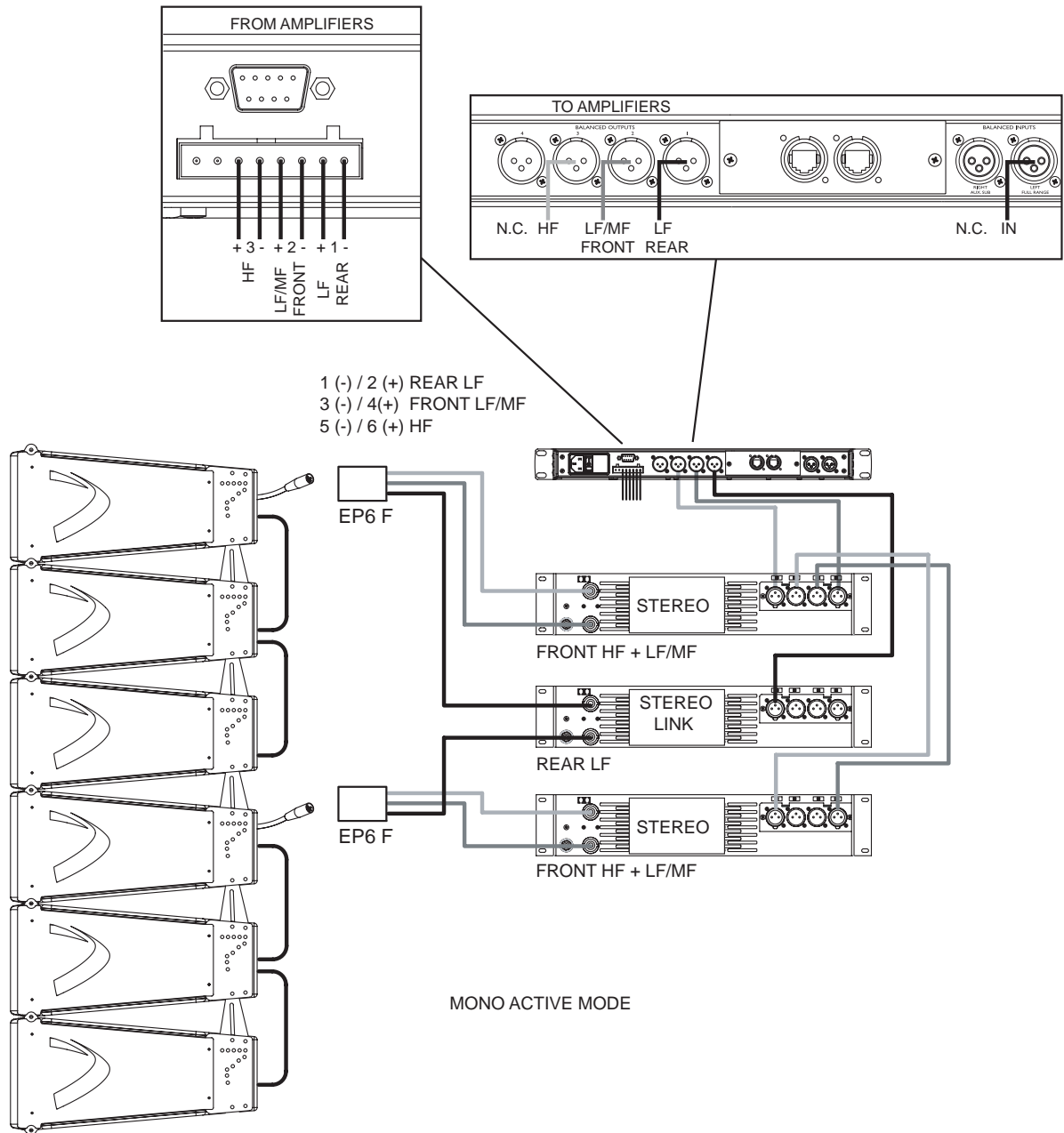

10.3 GEO SUB - GEO D cluster to amplifiers and NX242 (GeoD in Passive Mode)

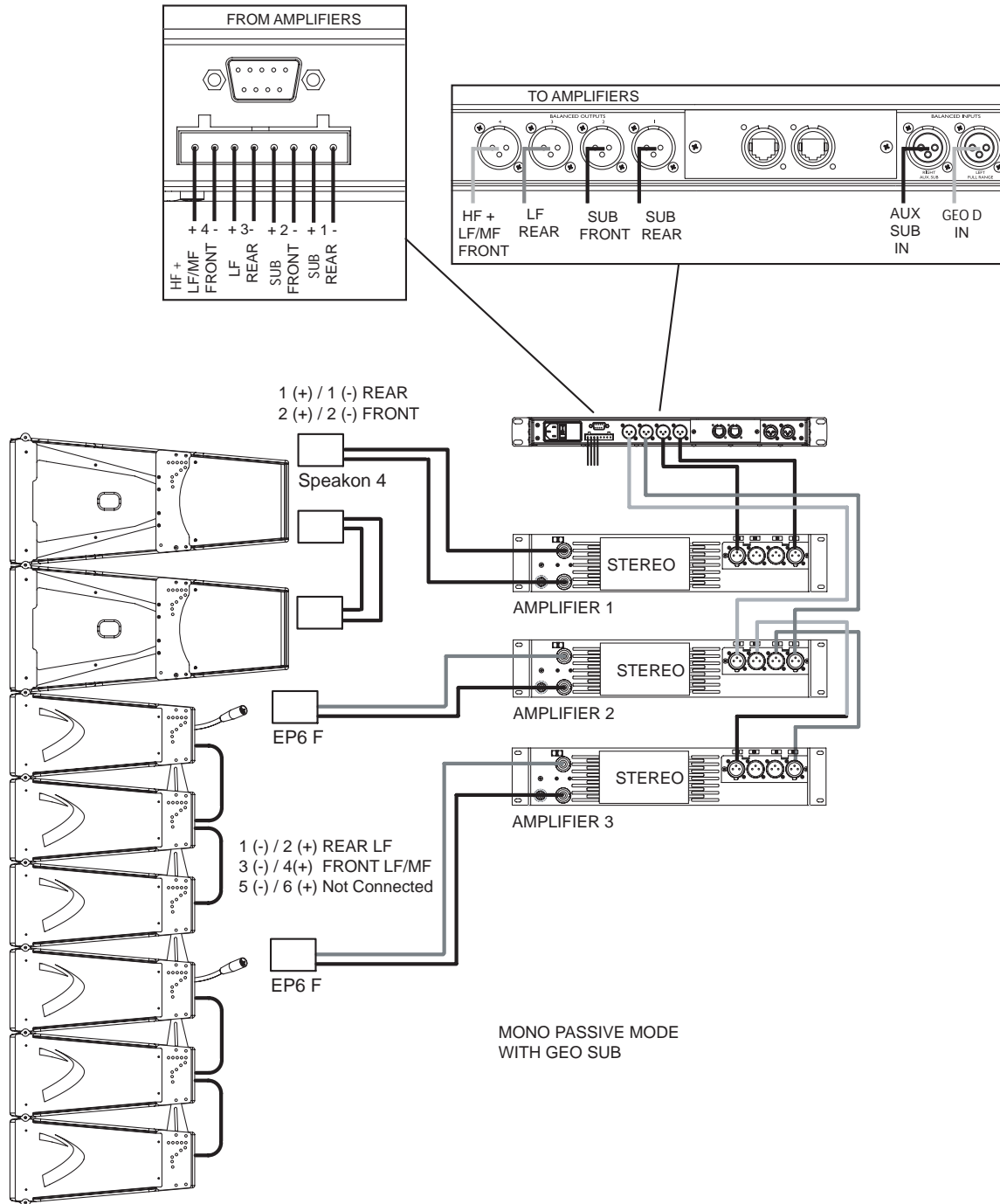





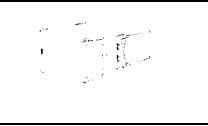
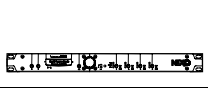



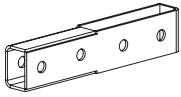

11 GEO D SERIES PARTS & ACCESSORIES LIST

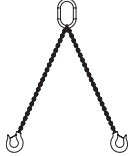

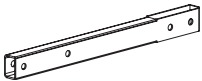
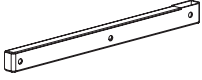

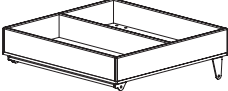

11.1 Array Modules & Control Electronics List

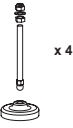
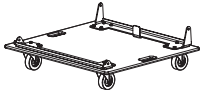
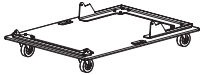
MODEL	DRAWING	DESCRIPTION
GEO D10		GEO D 10° Cardioid Main Module
GEO SUB		GEO SUB 10° Cardioid Sub-Bass Module
ANX 242		Digital TDcontroller for PS, Alpha and Geo series
NX-ES4		Ethersound Network & DSP Card for NX242

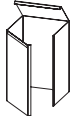
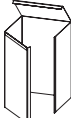
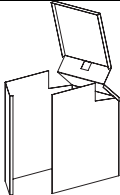
11.2 Accessories List

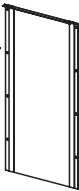
MODEL	DRAWING	DESCRIPTION
GEOD-BUMPER		Main Geo D Bumper
GEOD-BTBUMPER		Geo D Bottom Bumper
GEOD-EXBAR 1		Geo D Extension Bar for GEO D10 Cluster
GEOD-ORP		GEOD-EX1 Wheel for "One Rigging Point" Mode
GEO-BRIDLE		Two Legs Bridle for "One Rigging Point" Mode (One Adjustable Leg)

MODEL	DRAWING	DESCRIPTION
GEOD-EXBAR 2		Geo D Extension Bar for GEO D10 / GEOSUB Cluster
GEOD-EXBAR 3		Geo D Bottom Extension Bar for GEOSUB Cluster
GEOD-EXBAR4		Geo D Front Extension Bar for GEO D10 / GEO SUB Clusters
LEVA1500		Chain Lever Hoist 1.5 tonne (9 meters chain length)
LEVA750		Chain Lever Hoist 0.750 tonne (6 meters chain length)
CHBAG		Chain Bag
GEOD-BKM		GEO D10 Dolly Storage Tray
BLGEOD		GEO D 10mm x 20mm Quick Release Pin
GEOD-BNFIK		Kit for fixed installations per flown GEO D
GEOD-BUDP		GEO D Stands for Stacked GEO D Bumper
GEOD-DOLLY		3 x GEO D10 + 1 x GEOD-BUMPER Dolly
GEOSUB-DOLLY		2 x GEOSUB + 1 x GEOD-BUMPER Dolly

MODEL	DRAWING	DESCRIPTION
GEOD-DCOVER		Nylon Cover for <ul style="list-style-type: none"> • 3 GEO D10 • 1 GeoD-BKM or 1GEOD-BUMPER • 1 GEOD-DOLLY
GEOD-DCOVER4		Nylon Cover for <ul style="list-style-type: none"> • 4 GEO D10 • 1 GeoD-BKM or 1GEOD-BUMPER • 1 GEOD-DOLLY
GEOSUB-DCOVER		Nylon Cover for <ul style="list-style-type: none"> • 2 GEO SUB • 1 GeoD-BKM or 1GEOD-BUMPER • 1 GEOSUB-DOLLY
GEOD-RAINCOBP		Rain Cover for GEOD-BUMPER
GEOD-RAINCO		Rain Cover for up to 4 GEOD
BLT-RAP		T-RAP for BLGEOD
GEOT-CABLE		1m Cable For Geo D10
GEOT-613F		EP6 Female Connector
GEOT-612M		AP6 Male Connector

12 USER NOTES

France
Nexo S.A.
PA du Pré de la Dame Jeanne
BP5
F-60128 PLAILLY- FRANCE
Tel: +33 3 44 99 00 70
Fax: +33 3 44 99 00 30
E-mail: info@nexo.fr

www.nexo-sa.com