

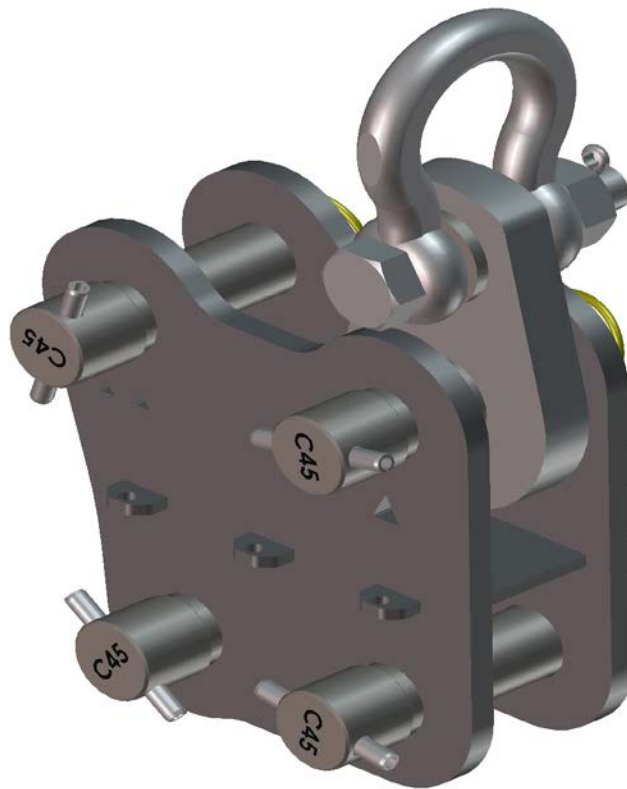



## Center Motor Rig Point



### Contents:

 <p><b>X1</b></p>	 <p><b>X4</b> <b>Pin30</b></p>	 <p><b>X1</b> <b>Centring</b></p>
--	---	--

**Weight: 8 Kg (Without Centring)**

**Dimensions:**

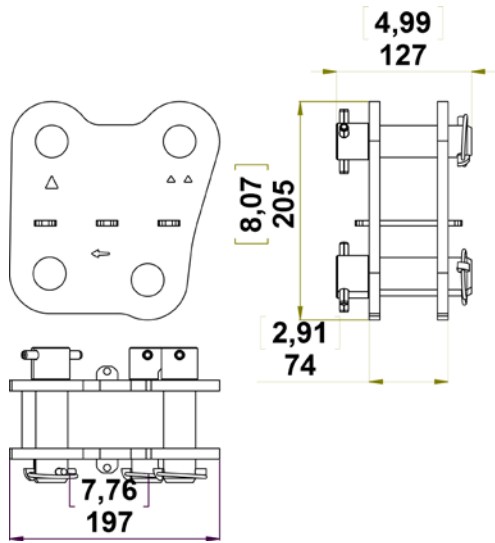

On XBOW	On MBEAM
