



DIGITAL TD CONTROLLER **nNXAMP4**

Scalable, cost-efficient
installed sound solutions



Retail



Restaurants



Bars



Houses of
Worship



Hotels



Education



Corporate

nexo-sa.com

Thinking. Inside the box.

NEXO

A
Yamaha
Group
Company



DIGITAL
TD CONTROLLER

Powerful, flexible



Multi-channel, networkable plug & play amplification and processing for NEXO installed sound systems

Available in standard and Dante-equipped versions, the 4-channel nanoNXAMP4 combined amplification and processing solution significantly reduces the cost of NEXO sound systems for retail, hospitality, houses of worship and corporate installations, without compromising the sound quality.

Ultra-low distortion and highly reliable Class D amplification delivers 4 x 250W, providing the same acclaimed sound quality and sonic signature as NEXO's larger NXAMPMK2 TD Controllers. Processing uses FIR filtering for precise system EQ and linear phase compatibility, with presets available for an edited range of speakers drawn exclusively from NEXO's popular ID and ePS Series.

With a universal mains voltage range of 100 to 240 Volts, on-board mixer and matrix functions further reduce the overall cost of smaller installations. Wall remote controls are available and can be configured to allow users to select sources and control volume.

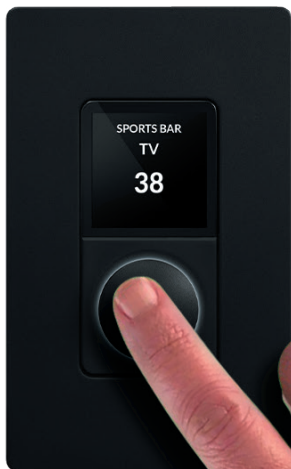

nanoNXAMP4

Small, compact, and cost-efficient



Restaurants



Bars



Retail



Houses of Worship



Hotels



Education

Comprehensive connectivity

Versatile and scalable

4x balanced/unbalanced analogue inputs essentially provide a 'double connectivity' which eases integration of the nanoNXAMP4. Balanced inputs can accommodate a dynamic microphone or professional mixer, while unbalanced inputs are perfect to connect a Bluetooth receiver, audio streamer or a computer audio output. The nanoNXAMP4 even includes a ducking and priority function to lower background music while the microphone is in use.



Also on the rear panel, an SPDIF In/Out can be used either as a digital input or to easily distribute a stereo signal across multiple nanoNXAMP4 units. For example, the first nanoNXAMP4-D (Dante version) can connect to the various sound sources in the role of an input matrix, then a fully digital stereo mix can be shared among multiple units simply by daisy chaining the SPDIF In/Out, keeping a full digital chain.

And a GPIO port adds additional facilities for an analogue volume control and a 12V trigger In / Out.

The nanoNXAMP4 is compatible with NEXO's NeMo remote control and monitoring tools for networked NEXO Powered TD Controllers, and industry-standard third party remote control protocols.



Rear panel connections

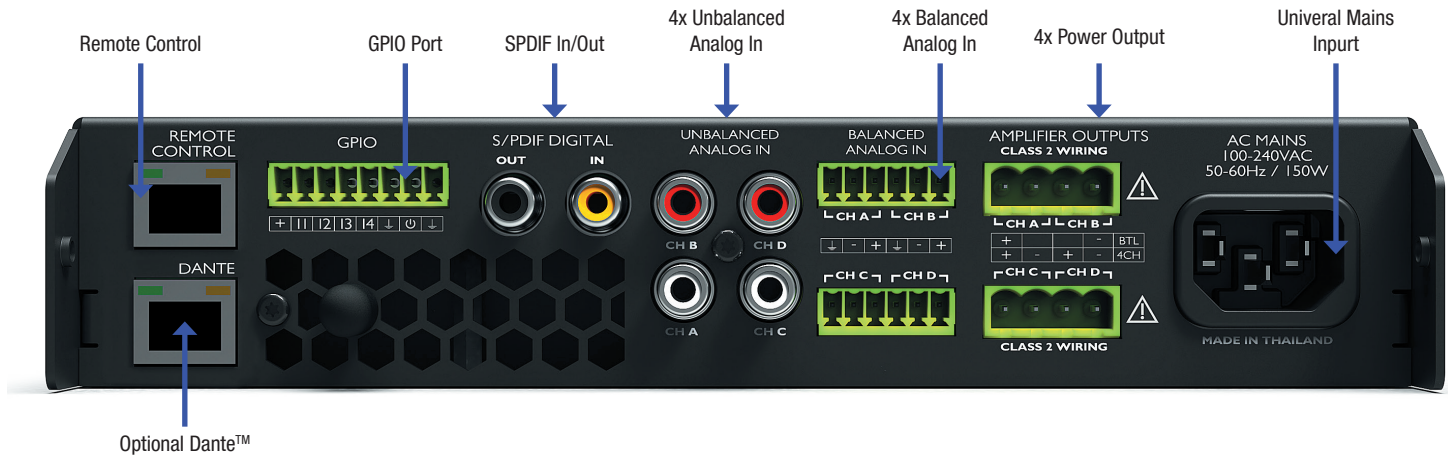

All trademarks are the property of their respective owners.

An intuitive web-based GUI for system design and set up

Configure and control systems from your laptop or smartphone without the need to install proprietary software

On-board mixer and matrix functions further reduce the overall cost of smaller installations, with set up and remote control enabled by an embedded web page that can be accessed via Ethernet or Wi-Fi.

Intuitive control is provided over a wide range of parameters including Inputs, Areas, Output Routing, NEXO Speaker Processing Presets, Delays and System Information.

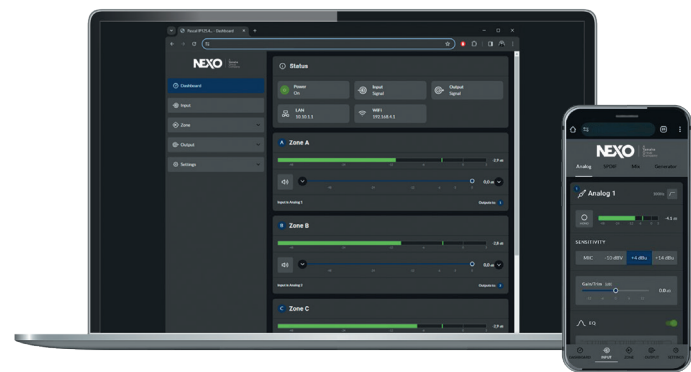

Existing NEXO amplification and processing solution

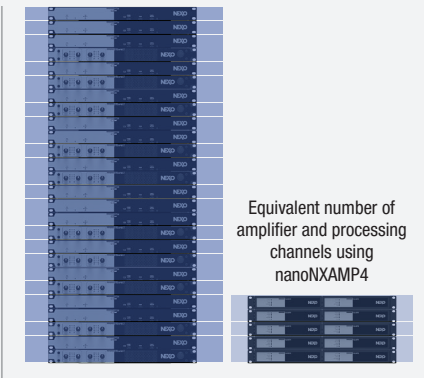

Space saving

The nanoNXAMP4 occupies just half a rack width and 1U height, increasing channel density. The integrated DSP offers a true 4x In / 4x Out architecture with optional Dante connectivity, all without the need of external processing, leading to significant space-savings over existing NEXO amplifier solutions while also saving cost and reducing cabling.



Energy saving

The nanoNXAMP4 doesn't just save money and rack space, it also saves energy, with a sophisticated series of intelligent standby modes helping to achieve a class-leading Energy Star rating.

nanoNXAMP4 Scalable, cost-efficient installed sound solutions



ID14-I



Retail

Available in black, white and custom RAL colours, NEXO's ultra-compact ID14-I blends seamlessly into prestigious retail environments, delivering dynamic, full range sound with bass extension from an equally compact 8-inch sub.

Up to 2 x ID14-I can be powered by each channel of the nanoNXAMP, with 2 channels to power the subs. Input sources connect directly to the amplifier and can be selected with the wall-mounting remote, which also controls volume.





Suggested system for retail installations

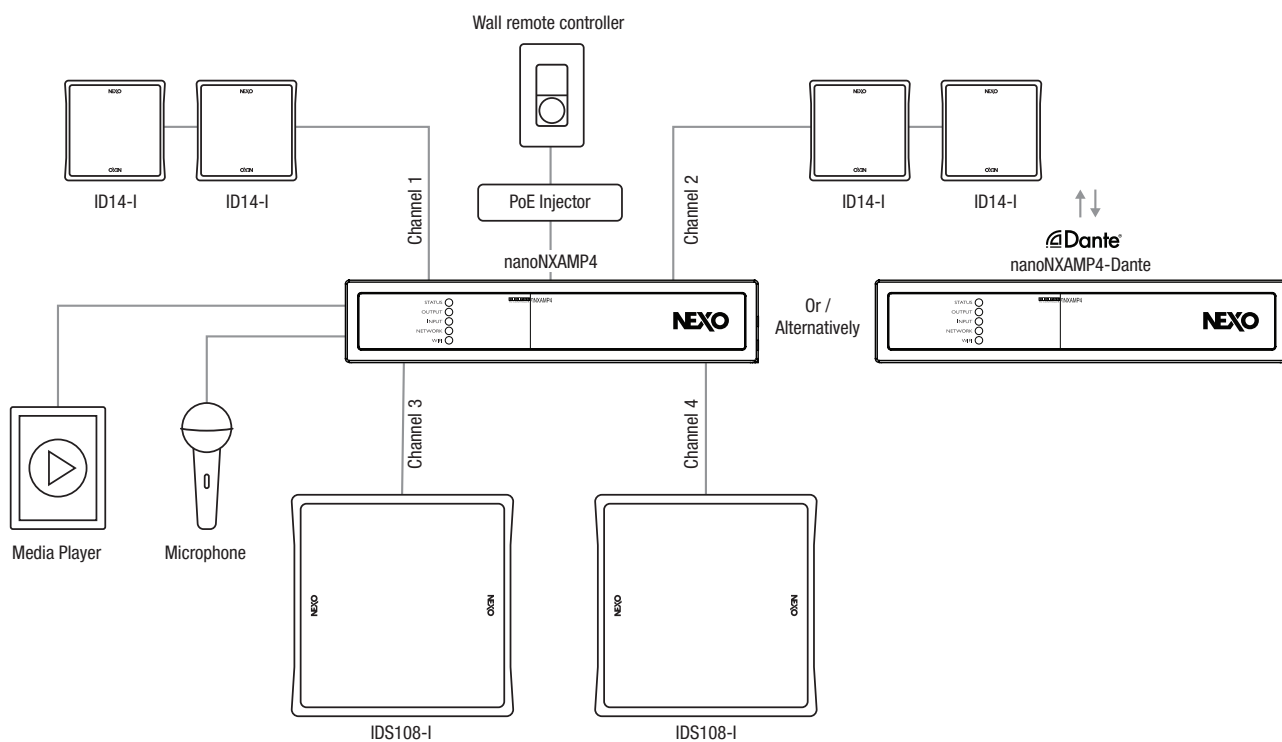

nanoNXAMP4 Scalable, cost-efficient installed sound solutions



Restaurants

Also available in black, white and custom RAL colours, and using an innovative V-formation of drivers, the ID24-I features a unique, rotatable horn which can be easily accessed by the system designer to ensure seamless coverage of dining, bar and reception spaces.

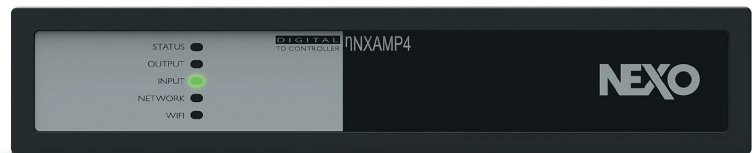

Up to 2 x ID24-I can be powered by each channel of the nanoNXAMP. Input sources connect directly to the amplifier and can be selected with wall-mounting remotes, which also control volume.



Suggested system for restaurant installations

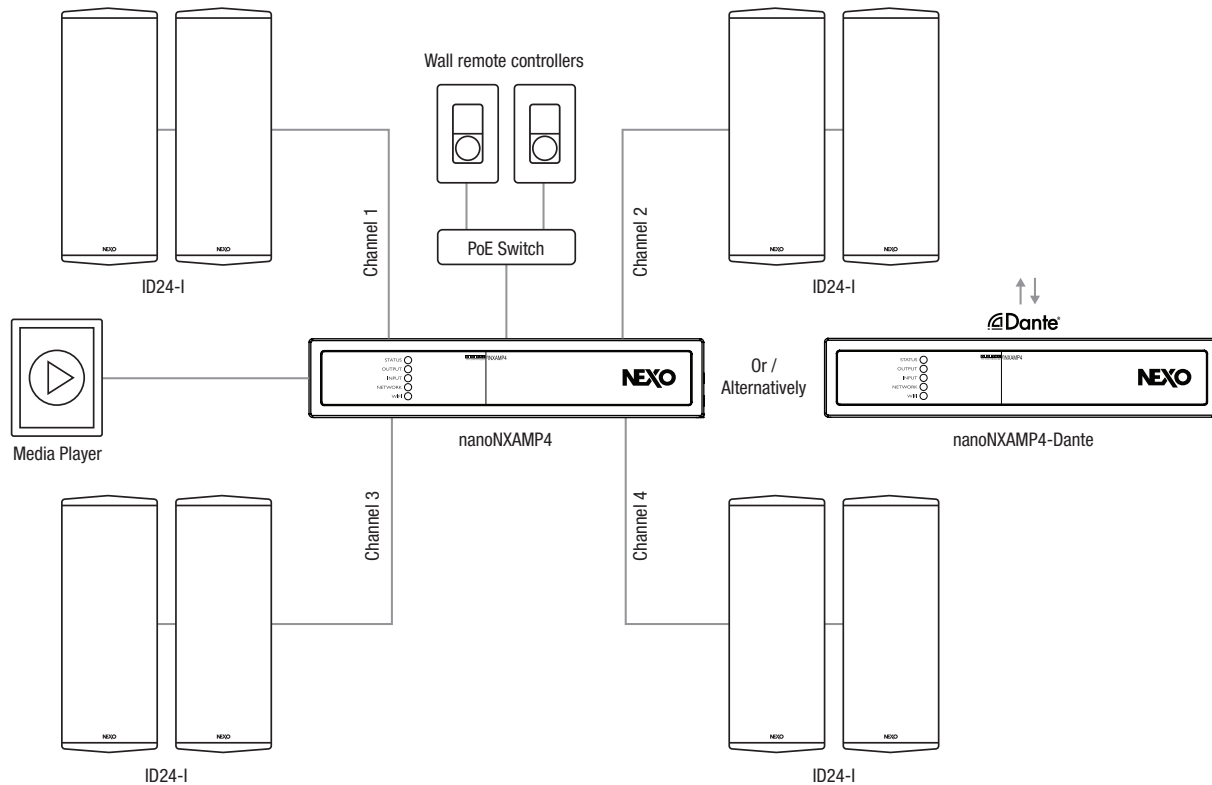



ePS8

Bars

The ePS builds on NEXO's industry-standard PS platform to create a 'no frills' range of point source installation loudspeakers, perfect for use in bars on everything from ambient music to DJ sets.

1 x ePS8 can be powered by each channel of the nanoNXAMP, with 2 channels bridged to power the eLS400 subs. Input sources connect directly to the amplifier and can be selected with the wall-mounting remote, which also controls volume.





Suggested system for bar installations

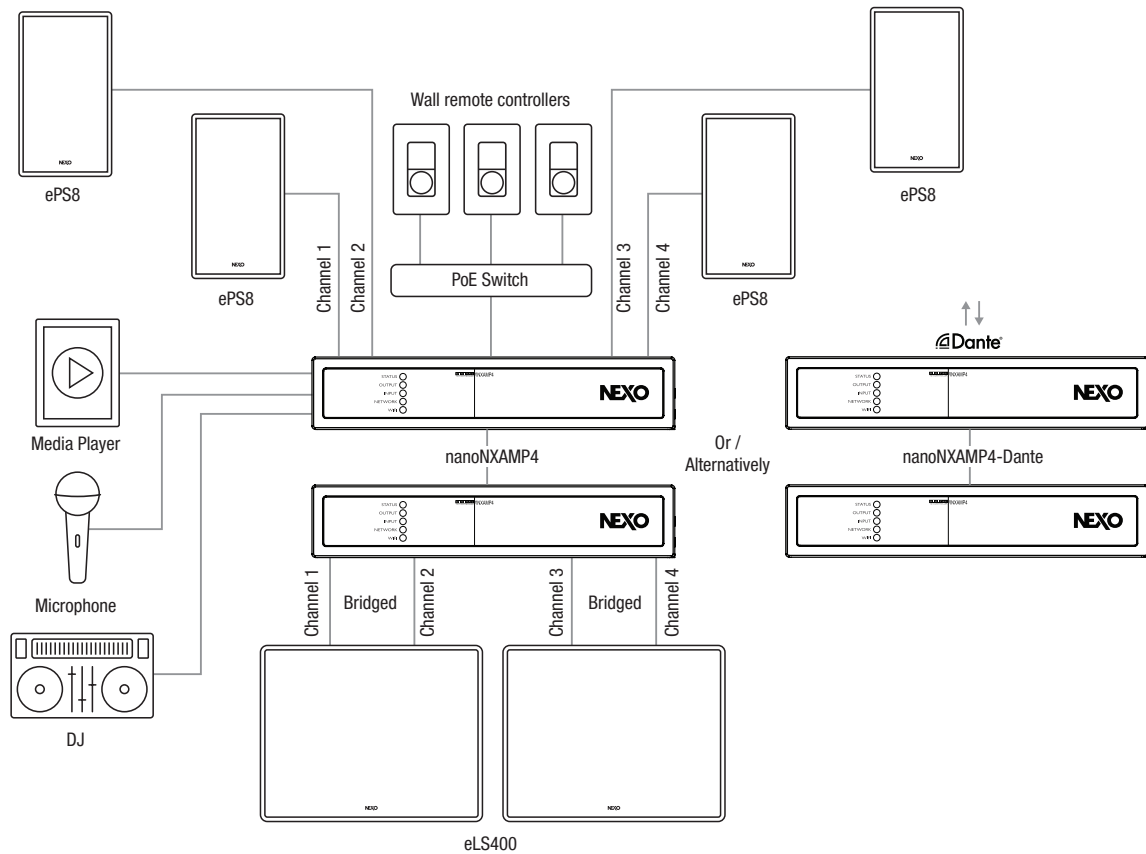



ID84-I

Houses of Worship

Available in black, white and custom RAL colours, the ID84-I uses eight 4-inch drivers and an array of dome tweeters on a curved baffle to deliver a 'hi-fi' performance that has come to redefine the column loudspeaker.

A popular choice in Houses of Worship where a line array might be impractical, one ID84-I can be powered by each channel of the nanoNXAMP, with additional channels required for the similarly proportioned ID84-L-I LF extension modules.

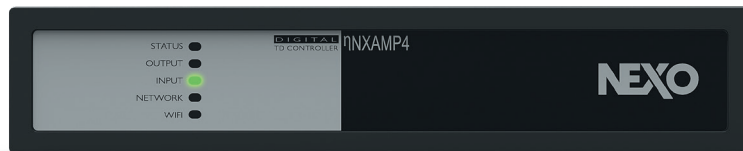



Suggested system for HOW installations

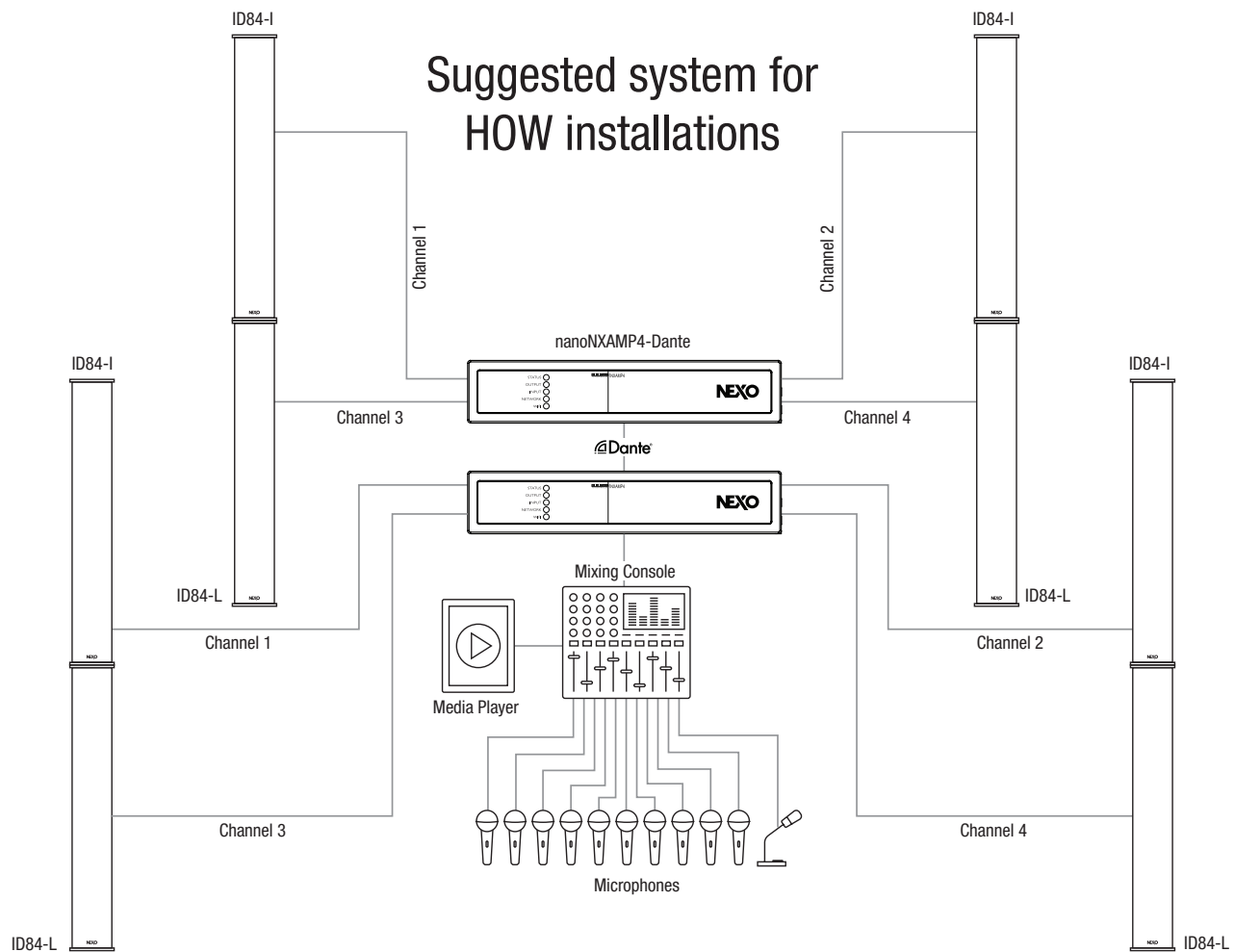

nanoNXAMP4 Scalable, cost-efficient installed sound solutions



Hotels, Education and Corporate Expanded Systems

With a shared sonic signature and linear phase compatible pre-sets, smaller nanoNXAMP4-D systems can be integrated with larger NXAMPmk2-powered configurations to create sophisticated, multi-zones, Dante-networked systems.



Suggested system for hotel installations

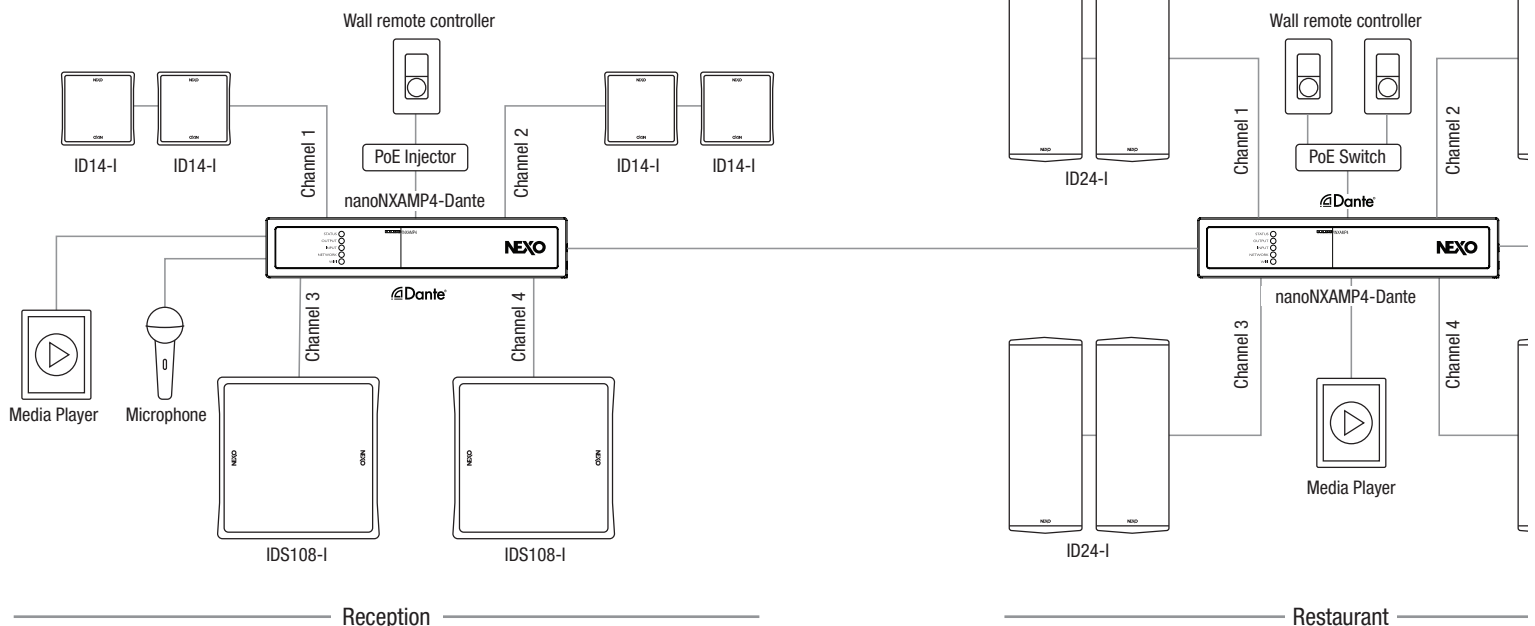

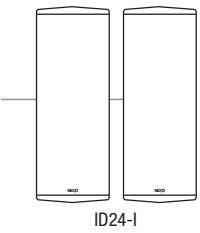

ID24-I

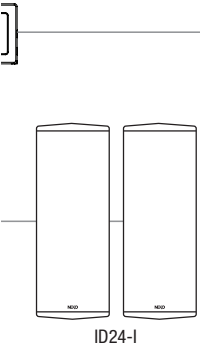

ID24-I

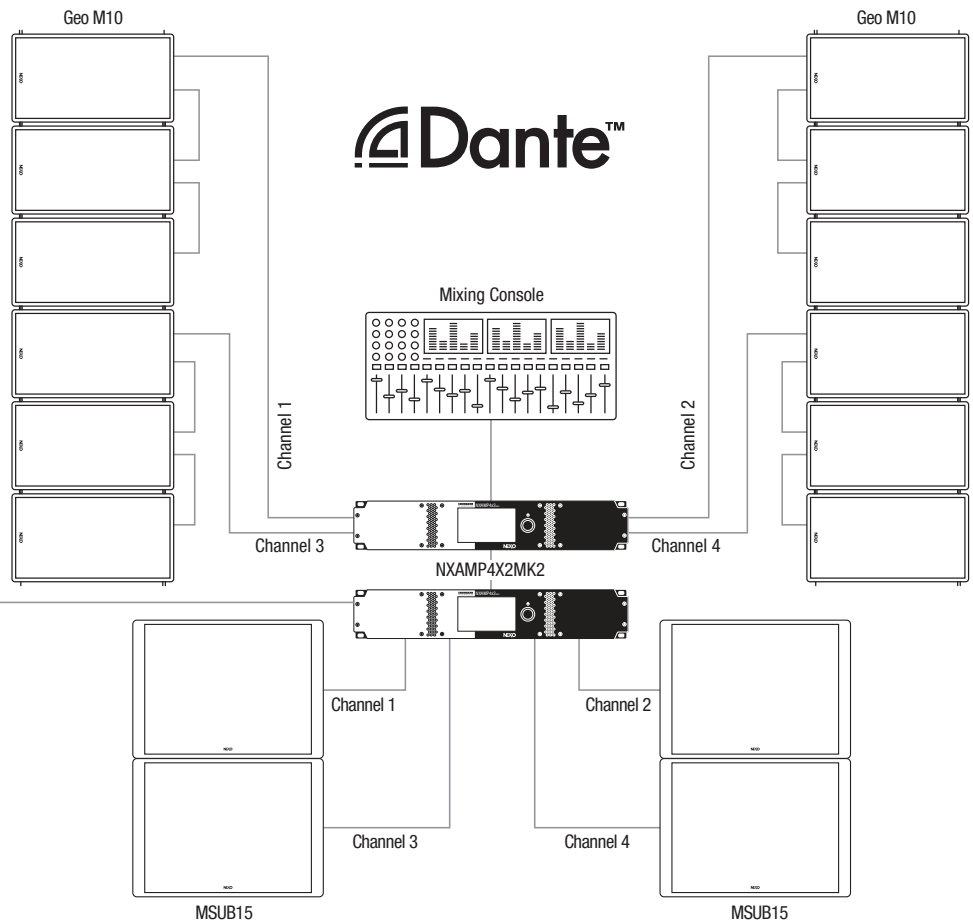

Ballroom



ID Series Accessories

ID14-I Installation Accessories

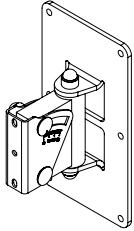

VNI-WM02
Versatile 25 kg max wall mount adapter 02 for indoor use

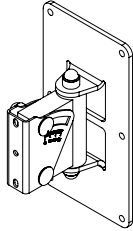

VNI-WM02-OU
Versatile 25 kg max wall mount adapter 02 for outdoor use

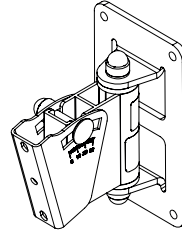

VNI-WM01
Versatile 15 kg max wall mount adapter 01 for indoor use

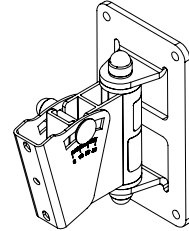

VNI-WM01-OU
Versatile 15 kg max wall mount adapter 01 for outdoor use

ID24-I Installation Accessories

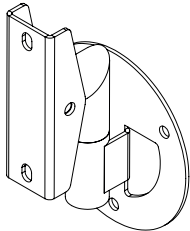

VNI-WB02
Versatile 15 kg max light wall mount adapter 02 for indoor use

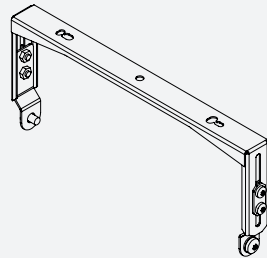

IDI-HBRK24
Bracket for ID24

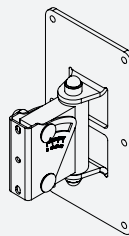

VNI-WM02
Versatile 25 kg max wall mount adapter 02 for indoor use

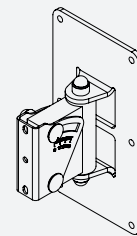

VNI-WM02-OU
Versatile 25 kg max wall mount adapter 02 for outdoor use

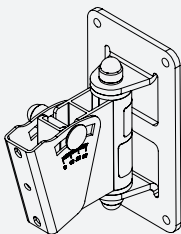

VNI-WM01
Versatile 15 kg max wall mount adapter 01 for indoor use

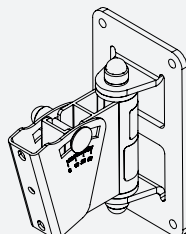

VNI-WM01-OU
Versatile 15 kg max wall mount adapter 01 for outdoor use

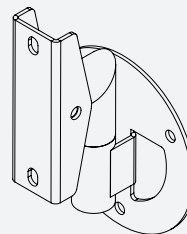

VNI-WB02
Versatile 15 kg max light wall mount adapter 02 for indoor use

ID84-I Installation Accessories

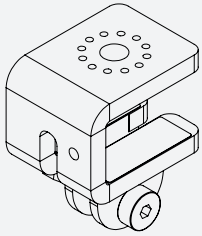

VNI-WMADAPT
Bumper to Wall Mount Adaptor

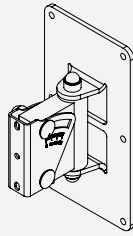

VNI-WM02
Versatile 25 kg max wall mount adapter 02 for indoor use

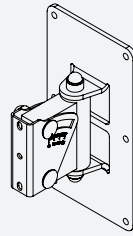

VNI-WM02-OU
Versatile 25 kg max wall mount adapter 02 for outdoor use

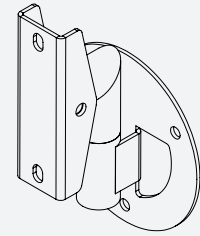

VNI-WB02
Versatile 15 kg max light wall mount adapter 02 for indoor use

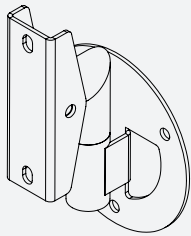

VNI-WB02-OU
Versatile 15 kg max light wall mount adapter 02 for outdoor use

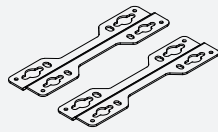

IDI-SWM01
Wall Mount Bracket for IDS110 / IDS210

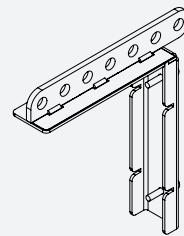

IDU-BUMP
Lifting bracket for ID84 and ID84L

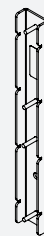

IDU-COUPPL
Coupling bracket for ID84 and ID84L

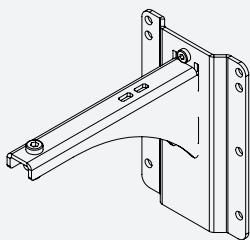

VNI-WM200
Wall mount 200 mm

IDS108-I Installation Accessories

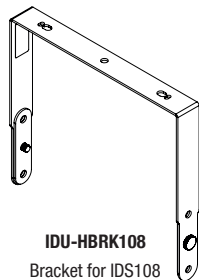

IDU-HBRK108
Bracket for IDS108

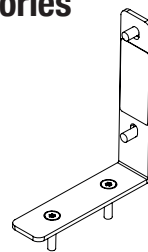

IDI-14T0108
Adapter ID14 to IDS108

ID Series Specifications

	ID14-I WITH NEXO PROCESSING		ID24-I WITH NEXO TDCO	
	ID14-I	IDS108-I	ID24-I	
Frequency Response @-6 dB	120 Hz to 20 kHz	50 Hz to 150 kHz	95Hz – 20kHz (+/- 6dB)	
Sensitivity	95 dB	95 dB	100 dB SPL Nominal	
Peak SPL@1m	116 dB	122 dB	126 dB	
Available Crossover Frequencies	120 Hz, 150 Hz	50-120 Hz, 50-150 Hz	95 Hz, 120 Hz, 150 Hz	
HF Dispersion	100° x 100° or 90° x 140°		60° x 60° 90° x 40° 120° x 40° 120° x 60°	
Nominal Impedance	16Ω	8Ω	16Ω	
Recommended Power	110 to 180 Watts / 16 Ohms (requires a 220 to 360 Watts / 8 Ohms amplifier)	350 Watts to 550 Watts / 8 Ohms	200 Watts to 500 Watts	
PRODUCT FEATURES		PRODUCT FE		
Number of ways	2 ways passive		2 ways passive	
Components	1 x Coaxial Neodymium LF 4" long excursion & HF 1.4 diaphragm	1 x 8" 8 Ohms Long excursion Neodymium driver	LF: 2 x 4" – Long excursion – Neodymium magnet HF: 1" voice coil ½" throat – Neodymium magnet	
Narrow/Wide mode selection				
Connectors	1 x Cable gland with 2 cores cable	1 x Cable gland with 2 cores cables	1 x Cable gland with 2 cores cables	
Rigging points	1 x M10 on each side for dedicated U bracket + 2 x M6 / 73 mm pitch at the back	2 x M10 Threaded inserts + 2 x M6 threaded inserts	6 x 6mm threaded inserts	
Construction	Water-resistant Polyurethane	Finnish birch plywood	Water-resistant Polyurethane	
Finish	Black: Raw sandblasted polyurethane / White: Structural paint	Black or White structural paint	White: Structural paint Black: Raw sandblasted polyurethane	
Front Finish	UV & Fire Resistant acoustic fabric fitted Magnelis® front grill	UV & Fire Resistant acoustic fabric fitted Magnelis® front grill	Stainless steel Acoustic fabric, black or white	
Operating temperature range	0°C - 40 °C (32° F - 104° F)	0°C - 40 °C (32° F - 104° F)	0°C - 40 °C (32° F - 104° F)	
Storage temperature range	-20 °C - 60 °C (-4 ° F - 140° F)	-20 °C - 60 °C (-4 ° F - 140° F)	-20 °C - 60 °C (-4 ° F - 140° F)	
Height x Width x Depth	130 mm x 130 mm x 120 mm (5.1" x 5.1" x 4.7")	305 x 307 x 305 mm (12.0" x 12.1" x 12.0")	132 x 309 x 23 3mm (5.2" x 12.2" x 9.2")	
Weight: Net	1.7 kg (3.7 lbs)	8 kg (17.6 lbs)	6 Kg (13 lbs)	
IP Rating	IP55	IP54	IP54	
SYSTEM OPERATION		SYSTEM OPE		
Recommended powering solution for maximum SPL	Up to 2x ID14 per nanoNXAMP4 channel	1x IDS108 per nanoNXAMP4 channel	Up to 2x ID24 per nanoNXAMP4 channel	

As part of a policy of continual improvement, NEXO reserves the right to change specifications without notice.

TDCONTROLLER SETUP	
IDS110-E	
43 Hz to 130 Hz (+/- 3dB)	
97 dB SPL Nominal	
125 dB	
85 Hz / 120 Hz	
4 Ω	
400 Watts to 650 Watts	

PRODUCT FEATURES	
1 x 10" Long excursion	
1x Cable gland with 2 cores cable	
4 x M6 inserts M20 flange (T version only)	
Finnish birch plywood	
Black structured paint	
0°C - 40 °C (32° F - 104° F)	
-20 °C - 60 °C (-4 ° F - 140° F)	
285 x 525 x 550 mm (11.2" x 20.7" x 21.7")	
21kg (47 lbs)	
IP2X	

SYSTEM OPERATION	
1x IDS110 per nanoNXAMP4 Bridged channels	

ID84-I WITH NEXO PROCESSING		
ID84-I	ID84-L-I	
90 Hz to 20 kHz	90 Hz to 1.5 kHz	
105 dB SPL Nominal	102 dB SPL Nominal	
135 dB	132 dB	
90 Hz, 120 Hz	90 Hz, 120 Hz	
Vertical: +0°/-10° (Narrow Mode) or +0°/-25° (Wide mode) Horizontal: 100°	Vertical: Depends on ID84-I Main module configuration and assembly Horizontal: 100°	
4 Ω	4 Ω	
650 to 1080 Watts / 4 Ohms	650 to 1080 Watts / 4 Ohms	

PRODUCT FEATURES		
2 way passive	1 way	
LF: 8 x 4" 8 Ohms long excursion Neodymium driver HF: 8 x 1" 8 Ohms HF driver on a patent-pending arrangement	LF: 8 x 4" 8 Ohms long excursion Neodymium driver	
Ruggedized, recessed, waterproof 2 position switch		
Cable gland with 2 x core cable	Cable gland with 2x core cable	
2 x pairs of M6 - 70 mm pitch rigging points + 2 x extra M6	2 x pairs of M6 - 70 mm pitch rigging points + 2 x extra M6	
Aluminum body and Magnelis® covers & grill	Aluminum body and Magnelis® covers & grill	
Black powder coating (RAL9005), White powder coating (RAL9016) or Custom RAL	Black powder coating (RAL9005), White powder coating (RAL9016) or Custom RAL	
UV & Fire resistant acoustic fabric	UV & Fire resistant acoustic fabric	
0°C - 40 °C (32° F - 104° F)	0°C - 40 °C (32° F - 104° F)	
-20 °C - 60 °C (-4 ° F - 140° F)	-20 °C - 60 °C (-4 ° F - 140° F)	
990mm x 150mm x 215 mm (39.0" x 5.9" x 8.5")	990mm x 150mm x 163 mm (39.0" x 5.9" x 6.4")	
15 kg (33 lbs)	14 kg (31 lbs)	
IP54	IP54	

SYSTEM OPERATION		
1x ID84 per nanoNXAMP4 channel	1x ID84L per nanoNXAMP4 channel	

ePS Series Specifications

	ePS6	ePS8	ePS10	eLS400
WITH NEXO PROCESSING				
Frequency Response @-6 dB	90 Hz to 20 kHz	80 Hz to 20 kHz	70 Hz to 20 kHz	45 Hz to 150 Hz
Sensitivity 1W@1m	98 dB SPL Nominal	100 dB SPL Nominal	101 dB SPL Nominal	102 dB SPL Nominal
Peak SPL@1m	125 dB	128 dB	130 dB	130 dB
Vertical Dispersion	+25°/-30°			
Horizontal Dispersion	50° to 100° Asymmetrical			
Crossover Frequency	90 Hz, 120 Hz	80 Hz, 120 Hz	70 Hz, 120 Hz	45-85 Hz, 45-120 Hz, 45-150 Hz
Nominal Impedance	8 Ω			6 Ω
Recommended Power	310 to 490 Watts / 8 Ohms	350 to 570 Watts / 8 Ohms	500 to 800 Watts / 8 Ohms	450 to 700 Watts / 6 Ohms (requires a 700 to 1000 Watts / 4 Ohms amplifier)
PRODUCT FEATURES				
Number of ways	2 ways passive			
LF Component	6" 8 Ohms long excursion driver	8" 8 Ohms long excursion neodymium driver	10" 8 Ohms long excursion neodymium driver	1 x Neodymium 12" 6 Ohms long excursion
HF Component	1.4" diaphragm 8 Ohms HF driver on an Asymmetrical Dispersion ("PS") horn			
Connectors	2 pairs (In/Out) of 7.62 mm pitch screw terminal blocks (+/- poles)			2 pairs (In/Out) of 7.62 mm pitch screw terminal blocks (+/- poles)
Compatible cables section	Cables from 0.75 mm ² to 3.3 mm ² (AWG 18 to 12) copper section			Cables from 0.75 mm ² to 3.3 mm ² (AWG 18 to 12) copper section
Compatible cables outside diameter	Cable with maximum outside diameter of 9 mm			Cable with maximum outside diameter of 9 mm
Rigging points	3x M6 - 70 mm pitch rigging points (back) + 2x extra M6 and 1x M10 (top/bot)			4 x pairs of M10 rigging points (two on each side)
Material	15 mm thick birch plywood body and galvanized grill			15 mm thick birch plywood body and Magnelis® grill
Finish	Black structural paint (RAL9005 or Custom RAL upon request)			Black structural paint (RAL9005 or Custom RAL upon request)
Front Finish	UV & Fire resistant acoustic fabric			UV & Fire resistant acoustic fabric
Height x Width x Depth	365mm x 198mm x 181mm (14.4" x 7.8" x 7.1")	423mm x 250mm x 227mm (16.7" x 9.8" x 8.9")	531mm x 316mm x 285mm (20.9" x 12.4" x 11.2")	365mm x 423mm x 450mm (14.4" x 16.7" x 17.7")
Weight: Net	7.1 kg (15.7 lbs)	8.1 kg (17.9 lbs)	14.8 kg (32.6 lbs)	14.5 kg (32 lbs)
Operating temperature range	0°C - 40 °C (32° F - 104° F)			0°C - 40 °C (32° F - 104° F)
Storage temperature range	-20 °C - 60 °C (-4 ° F - 140° F)			-20 °C - 60 °C (-4 ° F - 140° F)
IP Rating	IP55			IP55
SYSTEM OPERATION				
Recommended powering solution for maximum SPL	1x ePS6 per nanoNXAMP4 channel	1x ePS8 per nanoNXAMP4 channel	1x ePS10 per nanoNXAMP4 channel	1x eLS400 per nanoNXAMP4 Bridged channels

*Dimensions are within a tolerance of -0 +3 mm

ePS Series Accessories

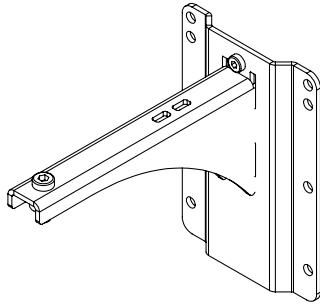

VNI-WM200
VNI-WM280
VNI-WM330
Wall mounting bracket

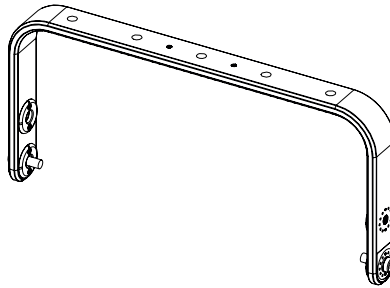

VNU-HBRK365 bracket for ePS6
VNU-HBRK425 bracket for ePS8
VNU-HBRK535 bracket for ePS10
Horizontal mounting bracket

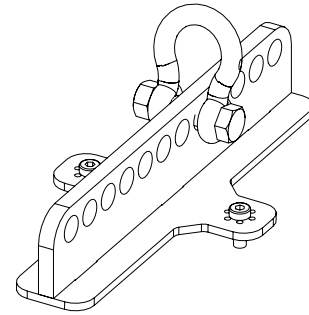

VNU-BUMP
Bumper mount

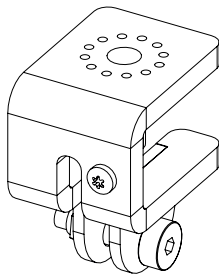

VNI-WMADAPT
Wall mount adapter

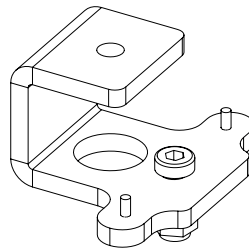

VNI-CLADAPT
Ceiling mount

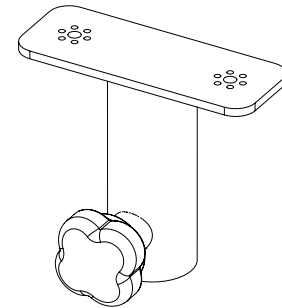

VNU-PLADAPT
Pole mount adaptor

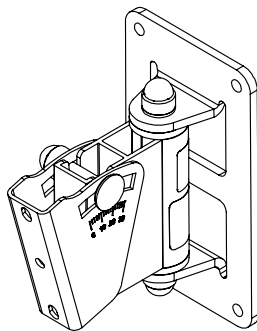

VNI-WM01
VNI-WM01-OU
VNI-WM02
VNI-WM02-OU
Variable angle wall mount

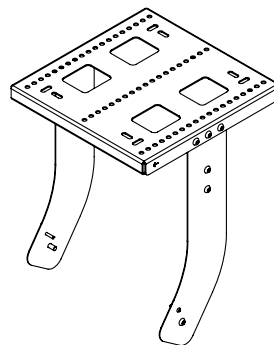

VNI-VCPL365 (ePS6 under eLS400)
VNI-HCPL425 (ePS8 under eLS400)

nanoNXAMP4 Specifications

POWER SPECIFICATIONS FOR nanoNXAMP4	
Number of channels	4 x amplifiers channels, 2 by 2 bridgeable
Max. output power (4 channels mode /4 Ohms load per channel)	4 x 250 Watts
Max. output power (4 channels mode /8 Ohms load per channel)	4 x 200 Watts
Max. output power (4 channels mode /2 Ohms load per channel)	4 x 250 Watts
Max. output power (2 channels mode /8 Ohms load per bridged channels)	2 x 200 Watts
Max. output power (2 channels mode /4 Ohms load per bridged channels)	2 x 350 Watts
Power consumption (Idle)	20 Watts
Power consumption (Standby)	<2 Watts
Power consumption (Standby without network)	<0.5 Watts
INPUT TO POWER OUT SPECIFICATIONS	
Frequency response	+0/-0.25 dB from 20 Hz to 20 kHz
Input impedance / Input Sensitivity	20 KΩ / +13 dBu
Dynamic range / TDH + N	>106 dB A-weighted / <0.05% on a flat setup
Latency	1 ms on a flat setup
Audio AD and DA Converters	24 bits @ 48 kHz
Processing	64 bits processing DSPs
BACK PANEL FEATURES	
Analog audio inputs	4 x balanced analogue inputs on Euroblock 3.5 mm pitch or unbalanced on RCA
Power outputs	4 x Euroblock 5 mm pitch outputs
Digital audio input/output	1 x SPDIF 2ch input/output on RCA + 1 x Dante™ 4ch input (nanoNXAMP4-D only)
GPIO port	1 x Euroblock 3.5 mm pitch with 4x Global purpose Inputs and 1 x Global purpose Output
Network inputs	1 x 100 Mb Ethernet port (Remote control)
Mains sockets	1 x IEC C14 socket
FRONT PANNEL AND REMOTE CONTROL	
Front panel LEDs	5 x LEDs (WiFi / Network / Output / Input / Status)
Remote control	Through 100 Mb Ethernet port or through integrated WiFi (Access Point or client)
MAINS REQUIREMENTS	
Mains voltage	Universal Power Supply with Active PFC 100 - 240 Volts (50/60 Hz)
Power consumption 1/8 max. 4 Ohms	250 Watts
DIMENSIONS AND CERTIFICATIONS	
Dimensions and weight	1U, 1/2 19" Rack, 44.5 x 220 x 296 mm (1.75 x 8.66 x 11.65"), 2.8 kg (6.2 lbs)
Electrical safety certification	IEC62368-1 2nd edition and UL62368-1
EMC certification	FCC Part 15 Class B, CAN/CSA-CISPR 22-10, EN55032/CISPR32, EN61000
Green status	Compliant with ROHS & Reach directive

NEXO loudspeaker systems supported by nanoNXAMP4 and nanoNXAMP4-D

Speaker	Maximum Per Channel
ID14	2
IDS108	1
ID24	2
ID84	1
ID84	1
ePS6	1
ePS8	1
ePS10	1
IDS110	1 per bridged channel
eLS400	1 per bridged channel

nanoNXAMP4 / 4-D Accessories



NANORK
Rack mounting accessory



NANOWM
Wall mounting accessory



NANORM-EU
Wall PoE Controller
Black (EU format)



NANORM-EUPW
Wall PoE Controller
White (EU format)

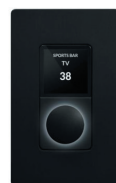

NANORM-US
Wall PoE Controller
Black (US format)



NANORM-USPW
Wall PoE Controller
White (US format)



NEXO
 Parc d'Activité
 du Pré de la Dame Jeanne
 B.P.5
 60128 Plailly
 FRANCE
 Tel: +33 (0)3 44 99 00 70
 Fax: +33 (0)3 44 99 00 30
 E-mail: info@nexo.fr



©2024 NEXO S.A. All Rights Reserved.
 All NEXO trademarks and service marks are the property of NEXO S.A., its subsidiaries and affiliated companies

nexo-sa.com

Thinking. Inside the box.

NEXO | A
 Yamaha
 Group
 Company

