



PS

NEXO S. A.
Parc D'Activité
du Pré de la Dame Jeanne
B.P.5
60128 PLAILLY
France
Tel: +33 (0)3 44 99 00 70
Fax: +33 (0)3 44 99 00 30
E-mail: info@nexo.fr

PS-R2 Series Systems

www.nexo.fr

NEXO

www.nexo.fr

NEXO

First we set the standard.
Then we raised the bar.

For more than 20 years, the NEXO PS Series has set the standard for compact, high-output loudspeakers. Now NEXO has raised the bar. The PS R2 Series builds upon the groundbreaking performance of its predecessor with even more power and bandwidth, greater versatility and better value in both installed sound and touring applications.

PS



More Power and bandwidth

More than 200,000 NEXO PS Series speakers are already hard at work around the world in applications where compact, high-output, linear response loudspeakers are required. The latest PS R2 Series delivers as much as a 5dB higher sound pressure levels from a range comprising three scalable systems, all of which can be quickly and easily configured for main PA use, for use as floor monitors, or flown vertically or horizontally in installations or for use as side/rear fills.

The PS R2 Series offers the user a totally integrated loudspeaker solution, in which innovative transducer, waveguide and enclosure designs come together under the control of strategic equalisation from a comprehensive range of Controllers and Amplifiers to ensure extended bandwidth and sound pressure levels, along with a high degree of speaker protection.

The Asymmetrical Advantage

A satisfactory audience experience often necessitates a compromise between the wide, short throw coverage required by listeners closest to the stage, and the narrow, long throw coverage required by those at the back of the venue. Similarly, coverage from monitors must be wider when the performer is closer to the speaker, and narrower when further away. The asymmetrical horns used in all PS R2 Series speakers are engineered such that the vertical coverage is narrower above horn axis

than below. A few minutes is all it takes to remove the grille, unscrew the horn and rotate it to ensure optimum directivity in every application. When used as the main PA, PS R2 systems significantly reduce the amount of ambient, reverberant energy caused when loudspeakers misdirect their output towards walls and ceilings. And in monitor mode, more of the output can be focussed on the performer.

Front-of house configuration

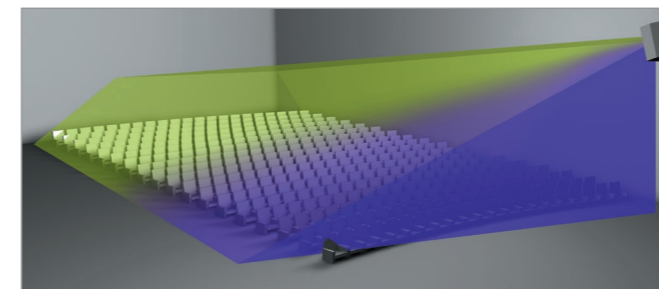
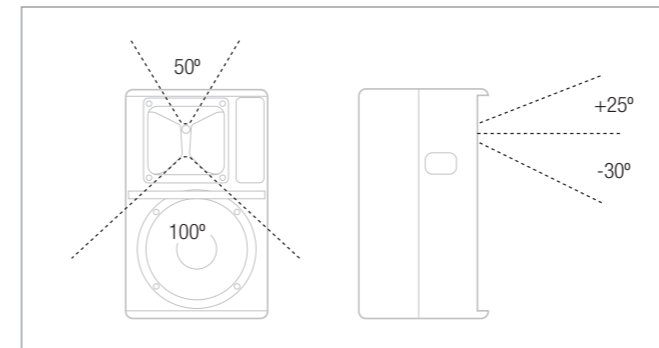

In conventional Front Of House configuration, a PS R2 Series loudspeaker yields 50° horizontal coverage at 25° above the centre line. Rotating the horn expands this to 100° at 50° below the centre line, such that coverage narrows.

Stage monitor configuration

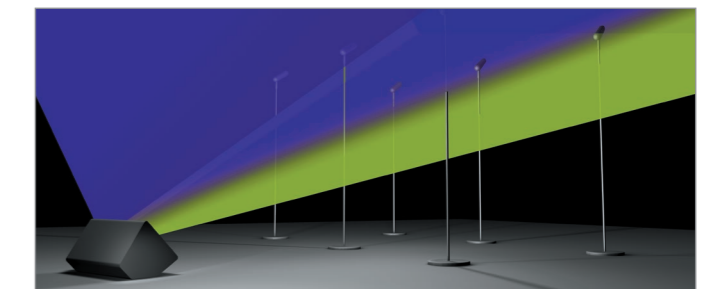
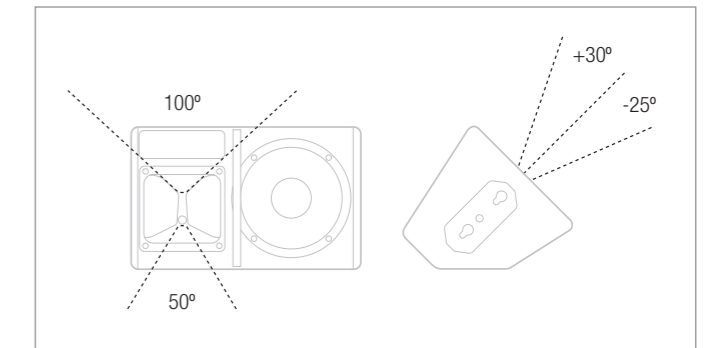

In stage monitor mode, a PS R2 Series loudspeaker yields 100° horizontal coverage at 30° above the centre line, narrowing to 50° horizontal coverage at 25° below the centre line for use when the performers are further away.

A sticker on the wide dispersion side of the horn indicates the correct orientation for FOH and wedge monitoring applications. The arrow on the sticker indicates the 'wide side' of PS horn dispersion. Users simply need to position the arrow such that it points in the direction requiring widest coverage, and away from the direction requiring narrowest coverage.

Greater Versatility

Central to the advanced performance of the PS R2 Series is NEXO's Asymmetrical Dispersion Constant Directivity horn design. Quick and easy for the user to rotate, it focusses more of the output of the loudspeaker on the audience (or performer when used as a monitor), greatly increasing the versatility of the system without compromising its performance in any given application.

FRONT OF HOUSE
wide dispersion
WEDGE MONITOR
wide dispersion

Faster Set up

The versatility of PS R2 Series loudspeakers is enhanced yet further by a full range of rigging and flying hardware (see pages 16/17) – the development of which benefits from NEXO's 30 years of experience in touring sound systems. And system installers will discover a similarly comprehensive range of mountings for permanent installation.

NEXO DTDAMP and DTD Controllers provide a powerful, compact and easy to configure power solution for PS-R2 systems in fixed and mobile applications.



DTDAMP and DTD Controller

A better Investment

PS Series loudspeakers have a hard-earned reputation for performance and reliability, with countless examples performing night-in, night-out, for more than a decade, without a single problem. Built in NEXO's new, state-of-the-art production facility in France and engineered from the outset for a long, trouble-free life, the new PS R2 Series is set to enhance this reputation yet further through a combination of even more exacting manufacturing standards and advanced driver protection technology.

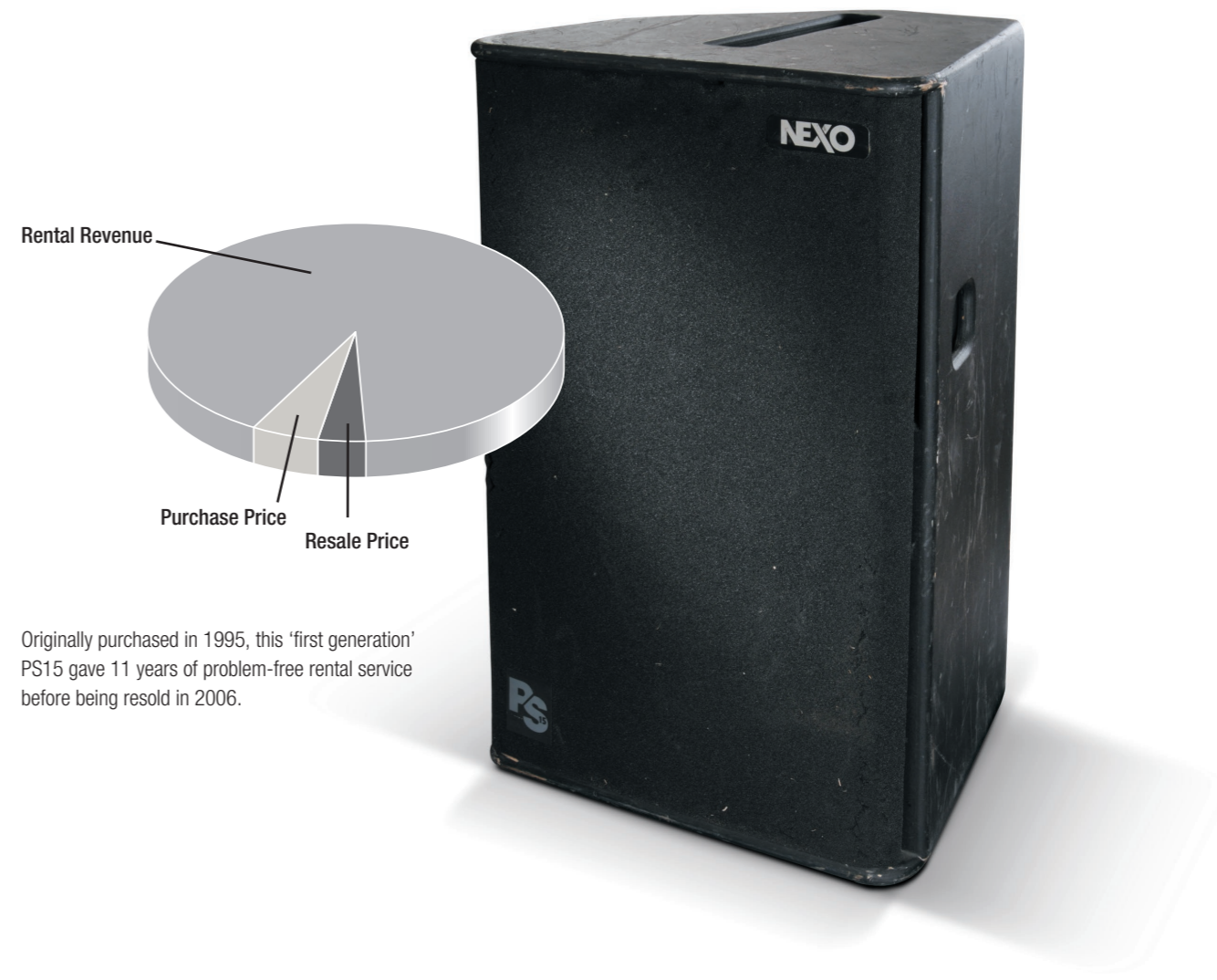

Originally purchased in 1995, this 'first generation' PS15 gave 11 years of problem-free rental service before being resold in 2006.



Key Features

- High-power system (125dB Peak SPL @ 1m) with new 8in LF and 1in HF low magnetic emission Neodymium drivers for light weight (7.5kg, 16.5lbs) and negligible magnetic leakage.
- Rotatable, asymmetrical horn and unique cabinet architecture ensure versatility; user-adaptable for both PA and stage monitoring applications.
- Two-way passive 8Ω design uses a single amplifier channel for simpler installation and lower cost.
- Sophisticated control electronics ensure reliable, linear operation. Supported with a full range of mounting and flying accessories.

Architectural and Engineering Specifications

The 2-way full range loudspeaker system shall have one 8 inch shielded neodymium cone transducer and a 1 inch shielded neodymium compression driver on a low distortion constant directivity asymmetrical dispersion horn. The system's horizontal coverage shall range from 50° to 100°, with vertical coverage of +25° and -30°. The user shall be able to rotate the horn in 4 directions as required by the application. The system shall have a Q of 10 and a Directivity Index that is 10 at frequencies above 1.8kHz. Nominal Sensitivity shall be 96dB (94dB wideband). When driven by a NEXO DTDAMP or a NXAMP powered controller the system shall be capable of 122dB to 125dB peak SPL, with a frequency response of 69Hz to 19kHz ±3dB (62Hz to 20Hz -6dB). The system shall include an internal passive crossover. Electrical connections shall be made via one of the two 4-pole NL4MP SPEAKON connectors.

The system shall have a tuned ported multi-angle enclosure constructed of 18ply Baltic birch, finished in textured black or white coating and having exterior dimensions no greater than 406mm H x 250mm W x 219mm D (16.0in H x 9.8in W x 8.6in D); the system shall weigh 7.5kg (16.5lbs). Exterior hardware shall include 3 mounting points (2 on the top, 1 on the bottom), 6 mounting points on the sides and 1-pole socket. Interior components shall be protected by a powder coated perforated steel grille. The system shall be the PS8 with a DTDAMP or a NXAMP powered controller.

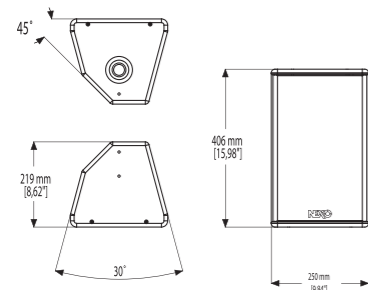

PS8 Loudspeaker



The PS8 features advanced NEXO designed low magnetic emission Neodymium drivers, making the PS8 extremely light and compact while usable next to magnetically-sensitive professional video or computer equipment. The dispersion, architecture and weight balance are designed to provide uncompromised PA and stage monitor performance from a single speaker, and background and foreground music playback applications are equally well-served.

Like the new PS10-R2 and PS15-R2, this flexibility is realized by a proprietary constant directivity asymmetrical dispersion horn, easily configurable (by users) in four positions by 90° rotations. Coupled with the horn's unique progressive horizontal (50° to 100°) and vertical (55°) dispersion, the most suitable pattern can be selected for vertical or horizontal PA usage or wedge monitoring. The PS8's 2-way passive 8Ω design employs a single amplifier channel to deliver bi-amped performance, reducing system cost, size and complexity, and a new grille design increases durability while fully accommodating use as a wedge.

System Applications

- Installed PA for clubs, A/V, theatre, broadcast, Houses of Worship, theme parks, etc.
- High-quality, low-profile stage monitoring for clubs, A/V, theatre, broadcast, etc.
- Near-field, down-fill and under-balcony systems in support of larger systems.
- Foreground and background music source for retail establishments seeking audio with impact.
- Anywhere powerful, high-quality performance is required near to magnetically-sensitive equipment.

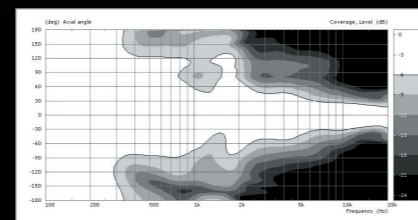

PS8 horizontal coverage, +25°

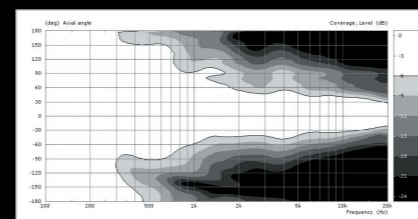

PS8 horizontal coverage, 0°

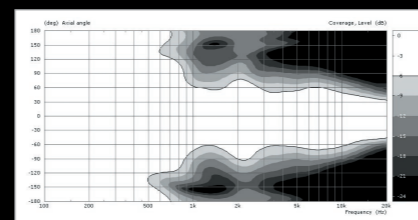

PS8 horizontal coverage, -25°



LS400 Sub-Bass

The LS400 Sub-Bass extends the usable range of the PS8 Loudspeaker to 40Hz, providing high performance and high power output (131dB Peak) in an extremely compact, light weight package. The NEXO-designed shielded 12in Neodymium driver allows the LS400 to be used in close proximity to magnetically sensitive video equipment.

Two LS400s are typically used with two PS8 loudspeakers, additional units may be used for an enhanced LF impact. PS8 and LS400 presets in the DTD Controller ensure cost-effective and simple system implementation while the NXAMP powered controller offers full network connectivity and the facility to combine PS8/LS400 configurations with any other Nexo cabinets.

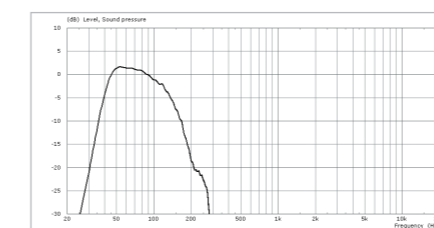

LS400 response

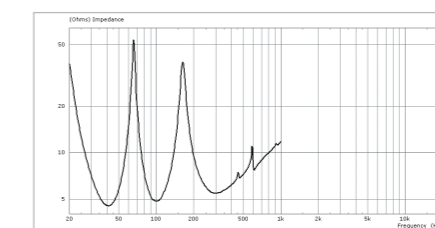

LS400 impedance

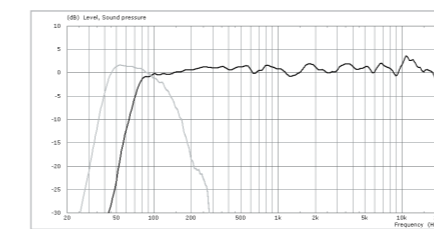

PS8 + LS400 response

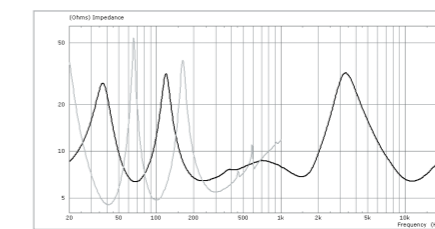

PS8 + LS400 impedance

LS400

LS400 Sub-Bass Key Features

- High-power system (131dB Peak SPL @ 1m) with 12in VLF low magnetic emission Neodymium driver for light weight (14.6kg, 32lbs) and negligible magnetic leakage.
- VLF extension (to 40Hz) of PS8 Loudspeakers. Sophisticated control electronics ensure reliable, linear operation.
- Integral pole mount that supports one or two PS8 Loudspeakers.

Architectural and Engineering Specifications

The sub-bass loudspeaker system shall have one 12in VLF shielded long excursion neodymium cone transducer. Nominal Sensitivity shall be 99dB. When driven by a NEXO DTDAMP or a NXAMP powered controller the system shall be capable of 128dB to 131dB peak SPL, with a frequency response of 43Hz to 120Hz ±3dB (40Hz to 140kHz -6dB). The system shall include an active crossover. Electrical connections shall be made via one of the two 4-pole NL4MP SPEAKON connectors.

The system shall have a tuned ported rectangular enclosure constructed of 18ply Baltic birch, finished in either black or white textured coating and having exterior dimensions no greater than 338mm H x 500mm W x 406mm D (13.3in H x 19.7in W x 16.0in D); the system shall weigh 19.3kg (43 lbs). Exterior hardware shall include 1-pole socket. The system shall be the LS400 with a DTDAMP or a NXAMP powered controller.

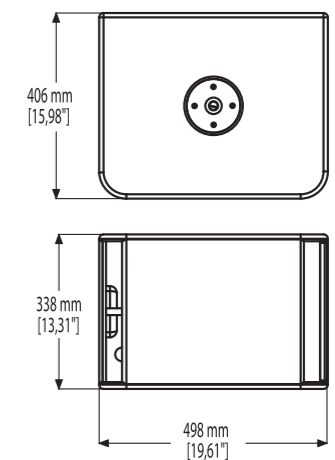



Key Features

- High-power system (132dB Peak SPL@1m) with 10in LF and 1in HF drivers.
- Rotatable asymmetrical horn and unique cabinet architecture ensure versatility.
- User-adaptable for both PA and stage monitoring applications.
- Two-way passive 8Ω design uses a single amplifier channel for simpler installation and lower cost.
- Sophisticated control electronics ensure reliable, linear operation.
- Supported with a full range of mounting and flying accessories.

Architectural and Engineering Specifications

The 2-way loudspeaker system shall have one 10 inch shielded Neodymium 8Ω cone transducer and a 1inch compression driver on a low distortion constant directivity asymmetrical dispersion horn. The system's horizontal coverage shall range from 50° to 100°, with vertical coverage of +25° and -30°. The user shall be able to rotate the horn in 4 directions as required by the application. The system shall have a Q of 16 and a Directivity Index that is 12 at frequencies above 3kHz. Nominal Sensitivity shall be 99dB (97dB wideband). When driven by a NEXO DTDAMP or a NXAMP powered controller the system shall be capable of 129dB to 132dB peak SPL, with a frequency response of 65Hz to 20kHz ±3dB (68Hz to 21Hz -6dB). The system shall include an internal passive crossover. Electrical connections shall be made via one of the two 4-pole NL4MP SPEAKON connectors.

The system shall have a tuned ported multi-angle enclosure constructed of 18ply Baltic birch, finished in either black or white textured coating and having exterior dimensions no greater than 515mm H x 316mm W x 277mm D (20.28 inches H x 12.4 inches W x 10.9 inches D); the system shall weigh 14 kg (31lbs). Exterior hardware shall include 1 metal plate, 2 attachment points and 1-pole socket. Interior components shall be protected by a powder coated perforated steel grille. The system shall be the PS10 with a DTDAMP and DTD Controller.

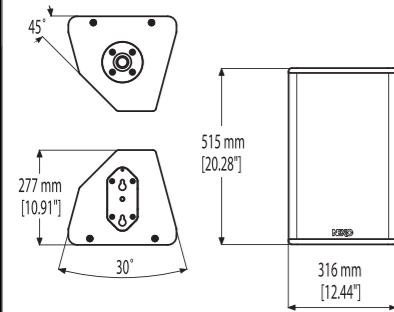

PS10-R2 Loudspeaker



A high power system capable of producing 132 dB Peak SPL, the new PS10-R2 Loudspeaker can be safely driven with up to 1250 Watts of amplifier power. Controlled by the new DTD Controller, the PS10-R2 achieves high SPLs and wide bandwidth performance, despite being only half the weight and volume of common trapezoidal loudspeaker systems.

Along with the flexible coverage patterns enabled by NEXO's proprietary constant directivity asymmetrical dispersion horn, the architecture and weight balance of the PS10-R2 are designed to provide both uncompromised PA and stage monitor performance from a single speaker. Left and Right versions of the PS10-R2 have been developed to provide a true stereo image – particularly important for wedge applications. The 2-way passive 8Ω design uses a single amplifier channel to deliver bi-amped performance, reducing system cost, size and complexity, while the new cabinet design incorporates a pole mount and a new hardware adapter compatible with a vast array of touring and fixed installation accessories.

System Applications

- Touring, installed PA for clubs, A/V, theatre, broadcast, Houses of Worship, etc. High-quality stage monitoring for cabarets A/V, theatre, broadcast, etc.
- Fill-in system for use with larger NEXO PS/Alpha systems, or any application needing exceptional side, down and near-field augmentation.

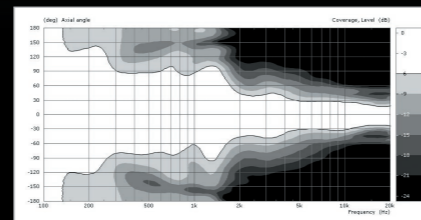

PS10-R2 horizontal coverage, +25°

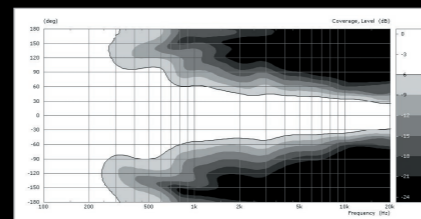

PS10-R2 horizontal coverage, 0°

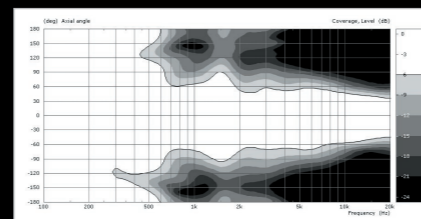

PS10-R2 horizontal coverage, -25°



LS600 Sub-Bass

A high power system capable of producing 138 dB Peak SPL, the new LS600 Sub-Bass extends the usable range of the PS10-R2 Loudspeaker to 38Hz, providing exceptional performance and high power output in an extremely compact, light weight package.

Two LS600s are typically used with two PS10-R2 loudspeakers, additional units may be used for an enhanced effect. PS10-R2 and LS600 presets in the DTD Controller ensure cost-effective and simple system implementation while the NXAMP powered controller offers full network connectivity and the facility to combine PS10-R2/LS600 configurations with any other Nexco cabinets.

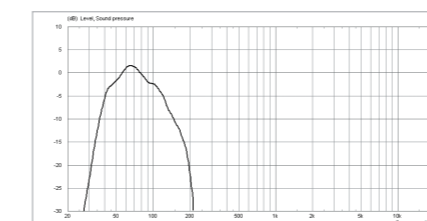

LS600 response

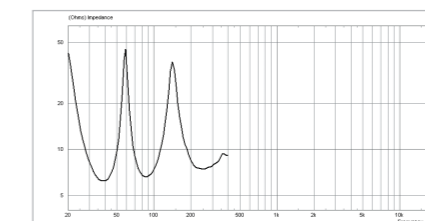

LS600 impedance

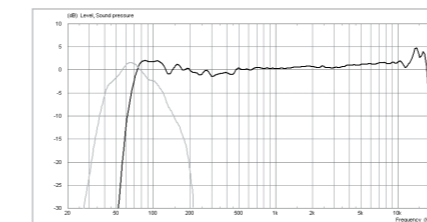

PS10-R2 + LS600 response

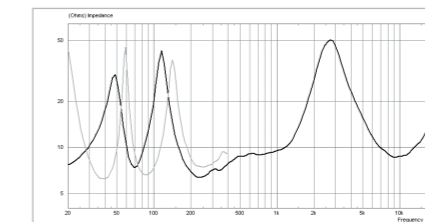

PS10-R2 + LS600 impedance

LS600

LS600 Sub-Bass

Key Features

- High-power system (138dB Peak SPL @ 1m) with 15in VLF long excursion driver.
- VLF extension (to 38Hz) of PS10-R2 Loudspeakers.
- Sophisticated control electronics ensure reliable, linear operation.
- Integral pole mount that supports one or two PS10-R2 Loudspeakers.

Architectural and Engineering Specifications

The sub-bass loudspeaker system shall have one 15 inch shielded Neodymium 8Ω long excursion cone transducer. Nominal Sensitivity shall be 101dB. When driven by a NEXO DTDAMP and DTD Controller the system shall be capable of 135dB to 138dB peak SPL, with a frequency response of 40Hz to 110Hz ±3dB (38Hz to 120kHz -6dB). The system shall include an active crossover. Electrical connections shall be made via one of two 4-pole NL4MP SPEAKON connectors.

The system shall have a tuned ported rectangular enclosure constructed of 18ply Baltic birch, finished in either black or white textured coating and having exterior dimensions no greater than 435mm H x 688mm W x 528mm D (16.9in H x 27.1in W x 20.8in D); the system shall weigh 30 kg (66lbs). Exterior hardware shall include 1 metal plate, 2 attachment points and 1-pole socket. Interior components shall be protected by a powder coated perforated steel grille. The system shall be the LS600 with a DTDAMP and DTD Controller.

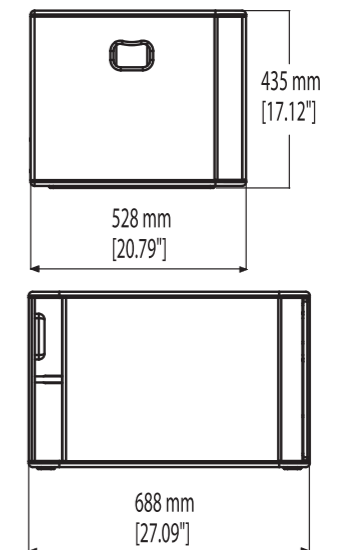

PS15

Key Features

- High-power system (136dB Peak SPL @ 1m) with 15in LF and 2in HF drivers.
- Rotatable asymmetrical horn and unique cabinet architecture ensure versatility; user-adaptable for both PA and stage monitoring applications.
- Two-way, switchable passive or active design for precise performance-matching to user requirements.
- Sophisticated control electronics ensure reliable, linear operation.
- Supported with a full range of mounting and flying accessories.

Architectural and Engineering Specifications

The 2-way loudspeaker system shall have one 15 inch shielded Neodymium 8Ω cone transducer and a 2 inch compression driver on a low distortion constant directivity asymmetrical dispersion horn. The system's horizontal coverage shall range from 50° to 100°, with vertical coverage of +25° and -30°. The user shall be able to rotate the horn in 4 directions as required by the application. The system shall have a Q of 16 and a Directivity Index that is 12 at frequencies above 1.5kHz. Nominal Sensitivity shall be 102dB (99dB wideband). When driven by a NEXO DTDAMP or a NXAMP powered controller the system shall be capable of 133dB to 136dB peak SPL, with a frequency response of 50Hz to 18kHz ±3dB (47Hz to 18Hz -6dB). The system shall include an active or passive crossover with internal switching. Electrical connections shall be made via one of the two 4-pole NL4MP SPEAKON connectors.

The system shall have a tuned ported multi-angle enclosure constructed of 18ply Baltic birch, finished in either black or white textured coating and having exterior dimensions no greater than 675mm H x 434mm W x 368mm D (26.6in H x 17.1in W x 14.5in D); the system shall weigh 29.0kg (65.0lbs). Exterior hardware shall include 1 metal plate, 2 attachment points and 1-pole socket. Interior components shall be protected by a powder coated perforated steel grille. The system shall be the PS15 with a DTDAMP or a NXAMP powered controller.

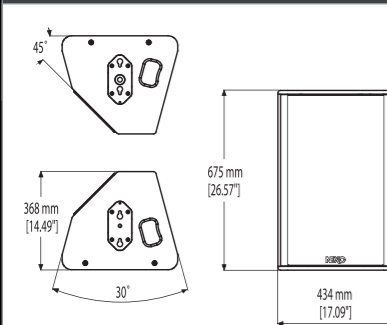

PS15-R2 Loudspeaker



A high power system capable of producing 136dB Peak SPL, the new PS15-R2 Loudspeaker can be safely driven with up to 2000 Watts of amplifier power. Controlled by the new DTD Controller, the PS15-R2 achieves high SPLs and wide bandwidth performance, despite being only half the weight and volume of common trapezoidal loudspeaker systems.

Along with the flexible coverage patterns enabled by NEXO's proprietary constant directivity asymmetrical dispersion horn, the architecture and weight balance of the PS15-R2 are designed to provide both uncompromised PA and stage monitor performance from a single speaker. Left and Right versions of the PS15-R2 have been developed to provide a true stereo image – particularly important for wedge applications. The 2-way passive 8Ω design uses a single amplifier channel to deliver bi-amped performance, reducing system cost, size and complexity, while the new cabinet design incorporates a pole mount and a new hardware adapter compatible with a vast array of touring and fixed installation accessories.

System Applications

- High-power mid-sized touring, installed PA for clubs, A/V, theatre, Houses of Worship, broadcast, etc.
- High-quality, extremely powerful stage monitoring for A/V, theatre, cabarets, broadcast, etc.
- Fill-in system for any PA requiring side, down and near-field augmentation.

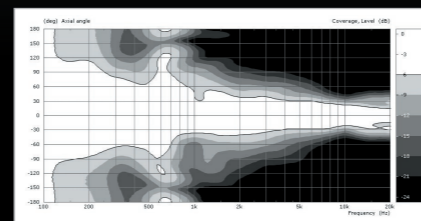

PS15-R2 horizontal coverage, +25°

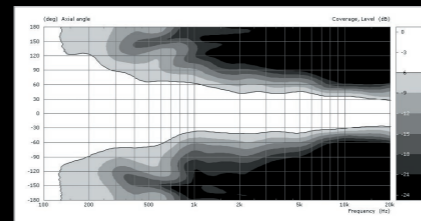

PS15-R2 horizontal coverage, 0°

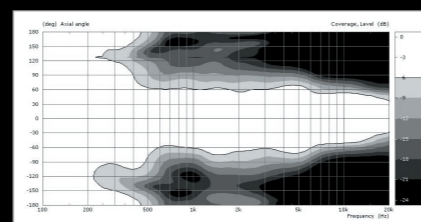

PS15-R2 horizontal coverage, -25°



LS18 Sub-Bass

Clever cabinet design empowers the LS18 sub bass module to bring new levels of versatility to NEXO PS Series systems.

The LS18 extends the useable range of the PS15-R2 loudspeaker to 35Hz, providing high performance and high power output (140dB peak).

Available in two versions, the standard LS18 features a steel pole mount on the top of the cabinet and plates on the side, compatible with PS Series rigging hardware. The LS18e is a stripped-down version, dispensing with rigging plates, handles and pole mount to deliver an exceptional price/performance ratio in fixed installations.

PS15-R2 and LS18 presets in the DTD Controller ensure cost-effective and simple system implementation while the NXAMP powered controller offers full network connectivity and the facility to combine PS15-R2/LS18 configurations with any other Nexco cabinets.

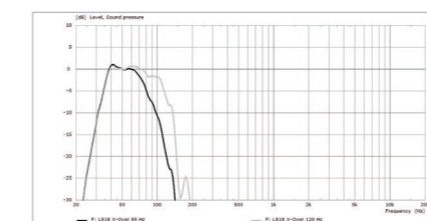

LS18 response

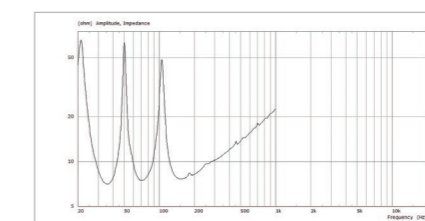

LS18 impedance

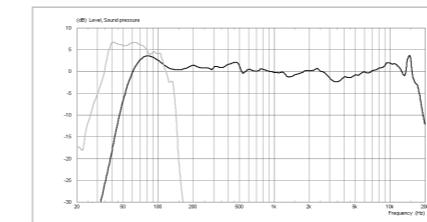

PS15-R2 + LS18 response

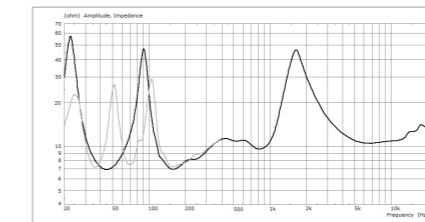

PS15-R2 + LS18 impedance

LS18

LS18 Sub-Bass Key Features

- High power system (137-140dB peak SPL @ 1m)
- VLF extension (to 30Hz) of PS15-R2 Loudspeakers
- 1 x 18", 4" voice coil long excursion 8Ω driver
- Light and easy to handle
- Integral pole mount

Architectural and Engineering Specifications

The sub-bass loudspeaker system shall have one 18in, 4" voice coil long excursion transducer. Nominal Sensitivity shall be 107dB. When driven by a NEXO DTDAMP or a NXAMP powered controller the system shall be capable of 137dB to 140dB peak SPL, with a frequency response of 35Hz to 120Hz ±3dB (32Hz to 130kHz -6dB). The system shall include an active crossover. Electrical connections shall be made via one of the two 4-pole NL4MP SPEAKON connectors.

The system shall have a tuned ported rectangular enclosure constructed of Baltic birch ply, finished in either black or white textured coating, or custom colours, and having exterior dimensions no greater than 510mm H x 675mm W x 775mm D (20.1in H x 26.1in W x 30.5in D); the system shall weigh 55.5kg (122.3 lbs). Exterior hardware shall include 1-pole socket and side mounting plates for attaching rigging hardware. The system shall be the LS18 with a DTDAMP or a NXAMP powered controller.

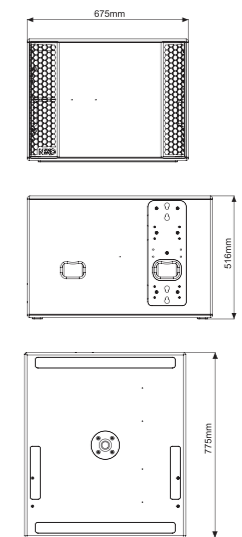

Specifications

PS8 Loudspeaker Specifications

Product Features	
Components	LF 1 x 8" (20 cm) Neodymium 8Ω driver HF 1 x 1" Neodymium throat driver + Low Distortion, Constant Directivity Asymmetrical Dispersion Horn.
Height x Width x Depth	406mm x 250mm x 219 mm (16" x 9 7/8" x 5 5/8")
Weight	7.5 kg (16.5 lbs)
Connectors	2 x NL4MP Speakon 4 pole
Construction	Baltic Birch Ply finished with textured black coating
Fittings	Moulded Dark Grey Metal Grill Flying Points & Fixed Installation Threaded inserts are fitted as standard to all cabinet surfaces for connection of mounting accessories
Stand fittings	Built-in Stand Fitting, (35mm / 1 3/8")

System Specifications PS8 with NEXO Controller

Frequency Response [a]	69 Hz - 19 kHz ±3dB
Usable Range @-6dB [a]	62 Hz - 20 kHz
Sensitivity 1W @ 1m [b]	96 dB SPL Nominal - 94 dB SPL Wideband
Nominal Peak SPL @ 1m [b]	122 to 125dB Peak
HF Dispersion [c]	50° to 100° Hor. x 55° Vert. Rotatable Horn, 4 positions Q : 10 Nominal DI : 10 dB
Directivity	Nominal (f > 1.8 kHz)
Crossover Frequencies	2.5 kHz Passive
Nominal Impedance	8Ω
Recommended Amplifiers	200 to 500 W / 8Ω

PS10-R2 Loudspeaker Specifications

Product Features	
Components	1 x 10" (25cm) Neodymium 8Ω driver HF 1 x 1" throat driver + Low Distortion Constant Directivity Asymmetrical Dispersion Horn.
Height x Width x Depth	515mm x 316mm x 277 mm (20.28" x 12.44" x 10.91")
Weight	14 kg (31 lbs)
Connectors	2 x NL4MP Speakon 4 pole
Construction	Baltic Birch Ply finished with textured black coating
Fittings	2 Metal recessed pockets
Front finish	Moulded Dark Grey Metal Grill
Flying Points	One plate connecting with external accessories
Stand fittings	Built in Steel Stand Fitting, (35mm 1 3/8")

System Specifications PS10-R2 with NEXO Controller

Frequency Response [a]	65 Hz - 20 kHz ±3dB
Usable Range @-6dB [a]	58 Hz - 21 kHz
Sensitivity 1W @ 1m [b]	99 dB SPL Nominal - 97 dB SPL Wideband
Nominal Peak SPL @ 1m [b]	129 to 132 dB Peak
HF Dispersion [c]	50° to 100° Hor. x 55° Vert. Rotatable Horn, 4 positions Q : 16 Nominal DI : 12 dB
Directivity Q & DI [c]	Nominal (f > 3 kHz)
Crossover Frequencies	2 kHz Passive
Nominal Impedance	8Ω
Recommended Amplifiers	500 to 1250 W / 8 Ω

PS15-R2 Loudspeaker Specifications

Product Features	
Components	LF 1 x 15" (38 cm) long excursion Neodymium 8Ω driver HF 1 x 2" throat, 3" Titanium diaphragm, driver + Low Distortion, Constant Directivity Asymmetrical Dispersion Horn.
Height x Width x Depth	675mm x 434mm x 368 mm (26.57" x 17.08" x 14.48")
Weight	28 kg (62 lbs.)
Connectors	2 x NL4MP Speakon 4 pole (switch passive to active inside).
Construction	Baltic Birch Ply finished with textured black coating
Fittings	Handles 4 Metal recessed pockets
Front finish	Moulded Dark Grey Metal Grill
Flying Points	Two plate connecting with external accessories
Stand fittings	Built in Steel Stand Fitting, (35mm 1 3/8")

System Specifications PS15-R2 with NEXO Controller

Frequency Response [a]	50 Hz - 18 kHz ±3 dB
Usable Range @-6dB [a]	47 Hz - 18 kHz
Sensitivity 1W @ 1m [b]	102 dB SPL Nominal. 99 dB SPL Wideband
Nominal Peak SPL @ 1m [b]	133 to 136 dB Peak
HF Dispersion [c]	50° to 100° Hor. x 55° Vert. Rotatable Horn - 4 positions Q : 16 Nominal DI : 12 dB Nominal (f > 1.5 kHz)
Directivity Q & DI [c]	Nominal
Crossover Frequencies	1.1 kHz Passive or Active (internally switchable)
Nominal Impedance	Passive : 8Ω or Active : LF : 8Ω & HF : 16Ω Important: Active Mode only available on NXAMP
Recommended Amplifiers	Passive: 1000 to 2000 W / 8Ω Active: (LF) 1000 to 2000 W / 8Ω - (HF) 250 to 500 W / 16Ω Important: Active Mode only available on NXAMP

LS400 Sub-Bass Specifications

Product Features	
Components	1 x 12" (30cm) long excursion 6Ω Neodymium driver
Height x Width x Depth	338mm x 500mm x 406mm (13 1/4" x 19 5/8" x 16")
Weight	19.5 kg (43 lbs)
Connectors	2 x NL4MP Speakon 4 pole
Construction	Baltic Birch Ply & textured black coating
Fittings	Handles 2 Metal recessed pockets
Stand fittings	Internal Stand Fitting on Top (35mm / 1 3/8") allows pole mounting

System Specifications LS400 with NEXO Controller

Frequency Response [a]	43 Hz - 120 Hz ±3dB
Usable Range @-6dB [a]	40 Hz - 140 Hz
Sensitivity 1W @ 1m [b]	99 dB SPL Nominal
Nominal Peak SPL @ 1m [b]	128 to 131 dB Peak
Crossover Frequencies	40-85, 40-120 or 60-120 Hz
Nominal Impedance	6Ω
Recommended Amplifiers	300 to 700 Watts / 4Ω

LS600 Sub-Bass Specifications

Product Features	
Components	1 x 15" (38cm) long excursion Neodymium 8Ω driver
Height x Width x Depth	435mm x 688mm x 528 mm (17.12" x 27.09" x 20.79")
Weight	30 kg (66 Lbs)
Connectors	2 x NL4MP Speakon 4 pole
Construction	Baltic Birch Ply & textured black coating
Fittings	Handles 2 Metal recessed pockets
Flying Points	One plate connecting with external accessories
Stand fittings	Internal Steel Stand Fitting on Top (35mm, 1 3/8") allows pole mounting

System Specifications LS600 with NEXO Controller

Frequency Response [a]	40 Hz - 110 Hz ±3dB
Usable Range @-6dB [a]	38Hz - 120 Hz
Sensitivity 1W @ 1m [b]	101 dB SPL Nominal
Nominal Peak SPL @ 1m [b]	135 to 138 dB Peak
Crossover Frequencies	40-85, 40-120 or 60-120 Hz
Nominal Impedance	8Ω
Recommended Amplifiers	1000 to 2000 Watts / 8Ω

LS18 Sub-Bass Specifications

Product Features	
Components	1 x 18" (46cm) 4" voice coil long excursion 8 Ω driver
Height x Width x Depth	510 x 675 x 775 mm (20.1" x 26.1" x 30.5")
Weight	55.5 kg (122.3 lbs)
Connectors	2 x NL4MP Speakon 4 pole
Construction	Baltic Birch Ply & textured black coating. Also available in white and custom paint finishes
Fittings	4 metal recessed pockets (2 per side)
Front finish	Moulded Dark Grey Metal Grill
Flying Points	Two side plates connecting with external accessories
Stand fittings	Internal Steel Stand Fitting on Top (35mm, 1 3/8") allows pole mounting

System Specifications LS18 with NEXO Controller

Frequency Response [a]	35 Hz - 120 Hz ±3dB
Usable Range @-6dB [a]	32Hz - 130 Hz
Sensitivity 1W @ 1m [b]	107 dB SPL Nominal
Nominal Peak SPL @ 1m [b]	137 to 140 dB Peak
Crossover Frequencies	35-85 or 35-120 Hz
Nominal Impedance	8Ω
Recommended Amplifiers	1000 to 2000 W / 8Ω

Sample Systems

2 x PS8 + 2 x LS400 powered by 1 x DTDAMP4x0.7 + DTD-T-U

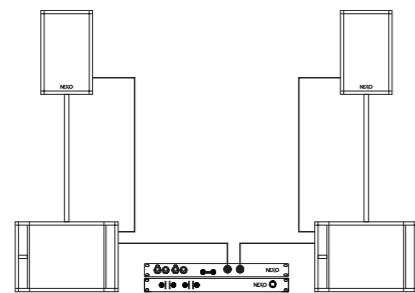

2 x PS10-R2 + 2 x LS600 powered by 1 x DTDAMP4x1.3 + DTD-T-U

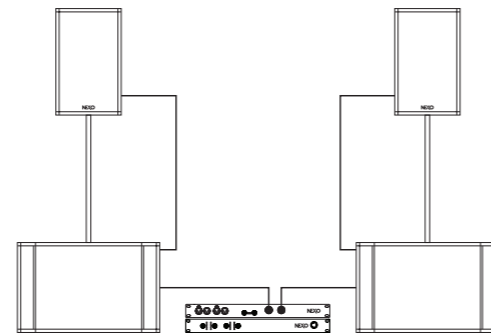

2 x PS15-R2 + 2 x LS18 powered by 2 x DTDAMP4x0.7 (Bridged) + DTD-T-U

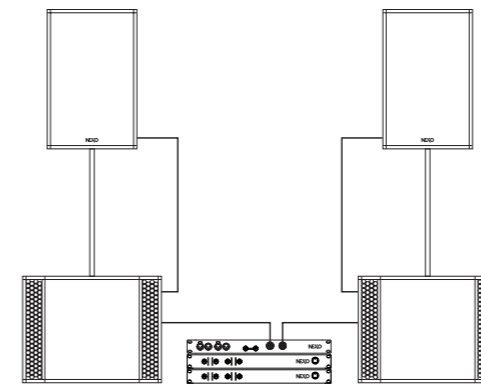

2 x PS15-R2 + 2 x LS18 powered by 1 x NXAMP4X4

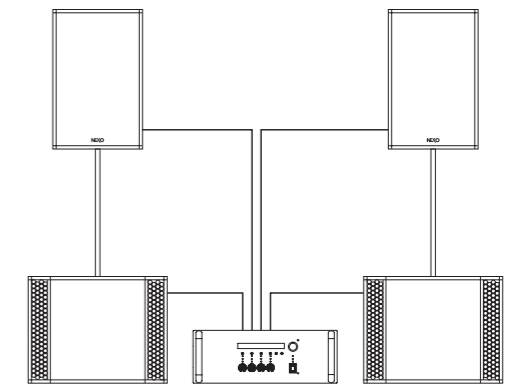

Mounting accessories



The PS R2 Series is supported by a comprehensive range of TUV certified mounting accessories designed to make it quick and easy to set up PS R2 Series systems in both mobile and fixed installations.

Sound contractors know that time is money, so PS R2 Series touring hardware draws on 30 years of NEXO experience to ensure maximum security and flexibility with minimum rigging time.

All PS R2 Series speakers ship with 35mm/1 3/8" pole mounts on the bottom of the cabinets for positioning on a general purpose speaker stand or mast inserted in top-fitted stand adapters on the sub-bass cabinets, while the PS10-R2 and PS15-R2 both feature steel anchor plates on the top for direct mounting onto a range of hanging and flying accessories (an adaptor plate is available for the PS8).

For outdoor installations, IP boxes are available giving full compliance with IP54 rating for protection from the harmful ingress of water.

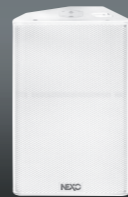

PS R2 Series Loudspeakers are also available in white.

Touring

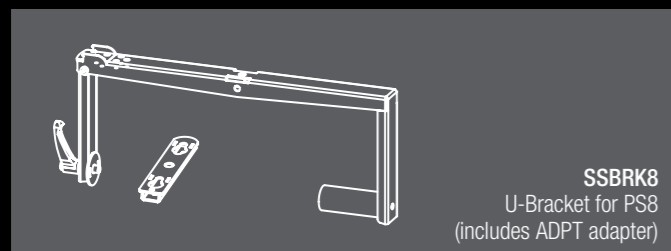

SSBRK8
U-Bracket for PS8
(includes ADPT adapter)

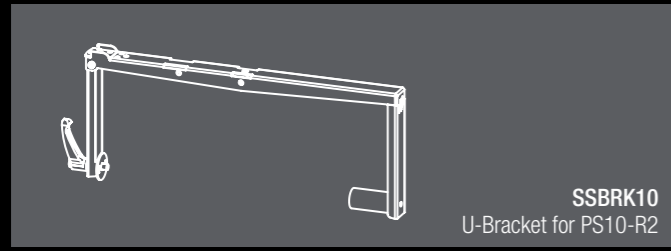

SSBRK10
U-Bracket for PS10-R2



SSBRK15 U-Bracket for PS15-R2



ADPT Hardware adapter for PS8



TTC Truss clamp bracket

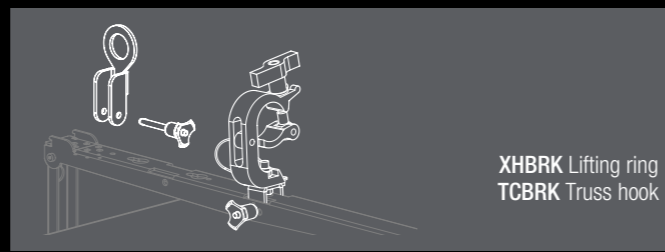

XHBRK Lifting ring
TCBRK Truss hook

Installation

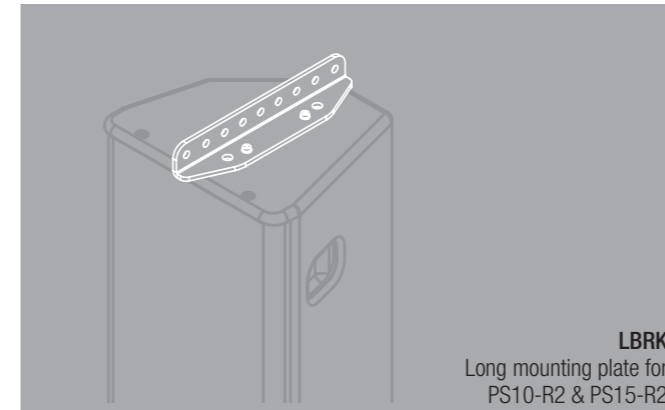

LBRK
Long mounting plate for
PS10-R2 & PS15-R2

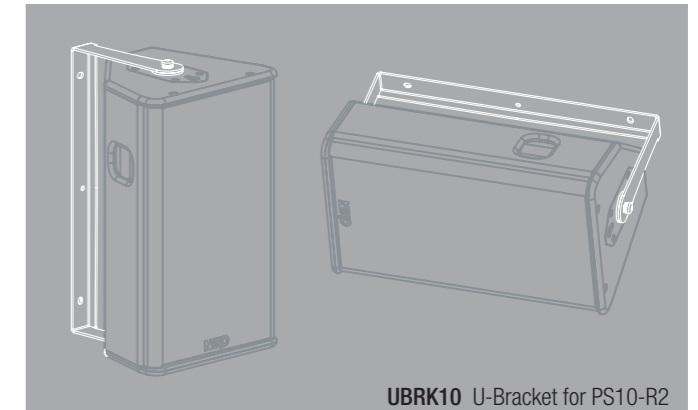

UBRK10 U-Bracket for PS10-R2

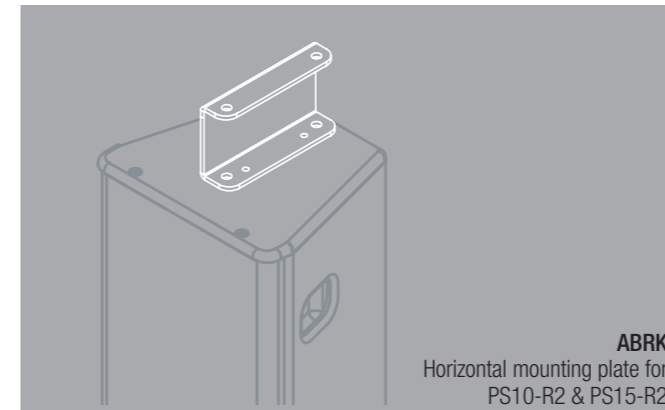

ABRK
Horizontal mounting plate for
PS10-R2 & PS15-R2

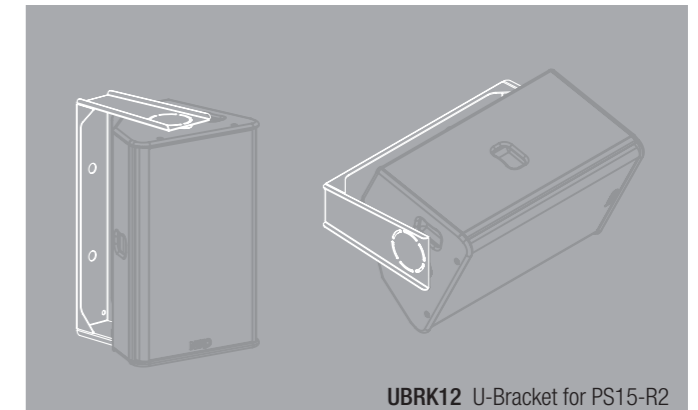

UBRK12 U-Bracket for PS15-R2

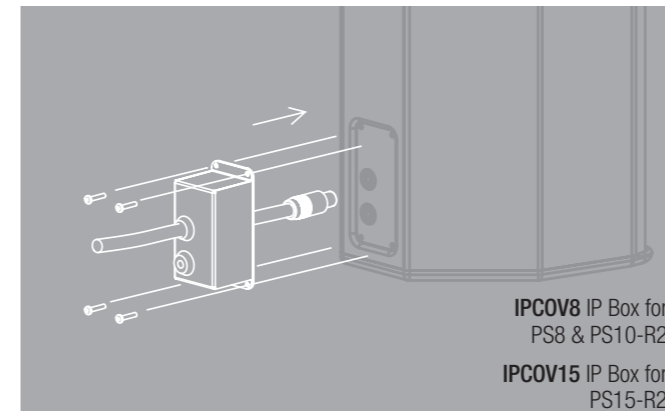

IPCOV8 IP Box for
PS8 & PS10-R2

IPCOV15 IP Box for
PS15-R2

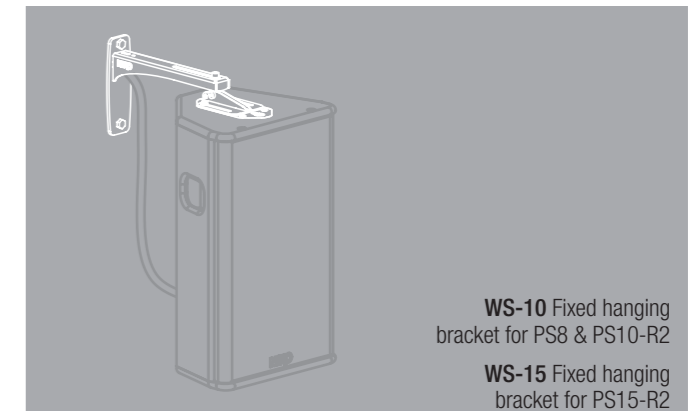

WS-10 Fixed hanging
bracket for PS8 & PS10-R2

WS-15 Fixed hanging
bracket for PS15-R2

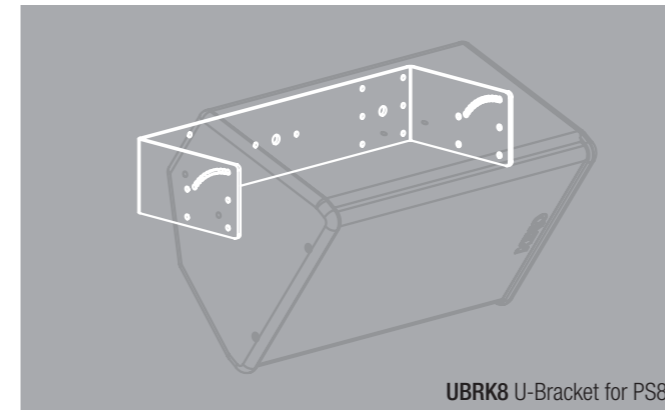

UBRK8 U-Bracket for PS8

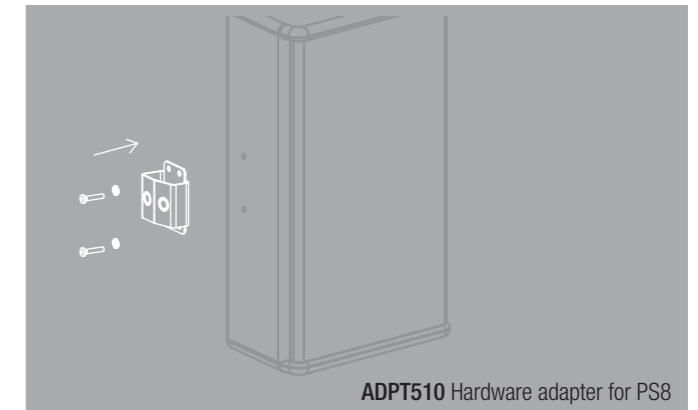

ADPT510 Hardware adapter for PS8

The perfect power solutions for PS-LS systems

DTDAMP and DTD Controller

Two ultra-lightweight, high-power and compact DTDAMP 4-channel amplifiers are perfectly matched to NEXO's DTD Controller to create the perfect power solution for PS-R2 systems.

Choose the 4 x 700 Watt or 4 x 1300 Watt (40hms) DTDAMP, then the Touring or Installation version of the DTD Controller. Then simply select the PS-R2 cabinets on the DTD Controller and no further adjustments are required – perfect for quick set-up and dry-hire.

The DTDAMP offers extensive protection including mains over / under voltage, over voltage or DC output on each channel, current and voltage peak limiters, short circuit protection and low-noise, variable-speed cooling.

Also compatible with other amplifiers, the DTD Controller is available in Touring version (with analogue input and output connectors on the front panel) and Install version (with all connectors on the back panel except USB for set-up from a Mac/PC or Android (with OTP support) device).

Full details of NEXO DTDAMP and DTD Controller are available to download from nexo-sa.com



DIGITAL DTDAMP
4 x CH AMPLIFIER

DIGITAL DTD
TD CONTROLLER

NXAMP

For the ultimate power solution, NEXO NXAMP 4x1 and 4x4 Powered TDControllers integrate loudspeaker and amplifier control into a single device to provide PS-R2 series users with a flexible, high-output amplification solution, with instant access to a large library of presets, including Monitor or Front of house, crossover frequency selection presets (PS10-R2/PS-15R2). Alongside all the control parameters necessary to optimise loudspeaker performance, the NXAMPs also enable the user to manage the voltage/current/sense lines from the output, protecting both the amplifier and its power supply in real time.

Two 4-channel models with output capacities of 4x1300W under 2Ω (4x1) and 4x4000W under 2Ω (4x4) establish the NXAMP 4x1 as one of the most versatile amplifiers in the business, and the NXAMP 4x4 as one of the most powerful amplifiers ever produced.



DIGITAL NXAMP
TD CONTROLLER

DTD Controller Specifications

Electrical Specifications	DTD-T-U	DTD-T-N	DTD-I-U	DTD-I-N
Sampling frequency and resolution	96kHz, 64-bit internal processing precision			
Signal delay	Less than 1 ms (analog in to out) on flat setup, compatible with NXAMP latency			
Frequency response	20 Hz to 20 kHz, +/-0.5 dB (mains out), 20 Hz to 20 kHz, +/-0.5 dB (sub out)			
Total harmonic distortion	Less than 0.003% (mains out), less than 0.02% (sub out)			
Dynamic range	112 dB (unweighted, mains out), 107 dB (unweighted, sub out)			
Crossover/channel separation	-100 dB (1kHz)			
Indicators	Analog in signal/peak (green/red), sense in signal (yellow), speaker protect (yellow)			
Display	White backlight graphical OLED display 96 x 16 pixels			
Switch and rotary knobs	3 position switch + 2 x rotary knobs			
Analog input characteristics				
Number of channels	2 electronically balanced analog inputs			
Connectors	2 x XLR-F with link on XLR-M		2 x terminal block (3-pin/2.54mm pitch)	
Sampling frequency and resolution	96 kHz/24-bit			
Max. input level/Input impedance	+22 dBu/20 kOhms			
Analog output characteristics				
Number of channels	3 electronically balanced analog outputs			
Connectors	3 x XLR-M		3 x terminal block (3-pin/2.54 mm pitch)	
Sampling frequency and resolution	96 kHz/24-bit			
Max. output level/Output impedance	+22 dBu/200 Ohms			
Amplifier sensing characteristics				
Number of channels	4 floating electronically balanced high voltage analog inputs			
Connectors	2 x 4 pole SP connectors		1 x terminal block (8-pin/5.08 mm pitch)	
Sampling frequency and resolution	96 kHz/24 bit			
Max. input level/Input impedance	+50 dBu (8000 Watts/8 Ohms) / 364 kOhms			
AES input characteristics				
Number of channels	1 AES/EBU stereo digital input			
Connectors	1 x XLR-F		1 x terminal block (3-pin/2.54 mm pitch)	
Sampling frequency and resolution	44.1 to 96kHz/16, 20 or 24-bit			
Dante™ input characteristics				
Number of channels	2 x Dante™ channels		2 x Dante™ channels	
Connector	1 x ruggedized RJ45		1 x RJ45	
Sampling frequency and resolution	48-96 kHz/24-bit		48-96 kHz/24-bit	
USB input characteristics				
Type	2 channels of USB audio			
Connector	DTD-I-U Female mini USB connector type B			
Sampling frequency and resolution	48kHz/16-bit			
Remote control				
Connector	Mini USB	Mini USB + RJ45	Mini USB	Mini USB + RJ45
Physical specifications				
Dimensions (W x H x D)	480 mm x 44 mm x 65 mm, 1U			
Weight	1.3Kg			
Power supply voltage	90 V - 240 V 50/60 Hz			
Power consumption	20 W max.			
Heat dissipation (per hour)	20 Kcal max.			
Operating temperature range	0°C - 40°C			
Storage temperature range	-20°C - 60°C			
Included items	Owners' manual + USB cable		Owners' manual, terminals plugs + USB cable	

NXAMP Technical Overview

Power Specifications	NXAMP4x1	NXAMP4x4
Number of amplifiers channels	4x channels, 2 by 2 bridgeable	4x channels, 2 by 2 bridgeable
Max. output voltage (no load)	4 x 105Volts	4 x 200Volts
Max. output power (8Ω)	4 x 600W	4 x 1900W
Max. output power (4Ω)	4 x 900W	4 x 3300W
Max. output power (2Ω)	4 x 1300W	4 x 4000W
Power consumption (Standby)	10W	20W
Power consumption (idle)	100W	150W
Power consumption (1/8 Power)	1100W	3000W

Common NXAMP Specifications from Analogue In to Power Out

Analogue Inputs channels	4x channels, analogue inputs on XLR 3 with a second XLR 3 for linking
Frequency response	±0.5dB from 10Hz to 20kHz
Input Impedance	20kΩ
Max Input Level	+28dBu
Dynamic Range	All Channels = 105dB unweighted
THD + Noise	Typical 0.1% flat setup
Latency time	500us on a flat setup
Power Supply	Dedicated version for 100 – 120Volts or 220 – 240Volts

DTD Amp Specifications

Power Specifications	DTDAMP4x0.7	DTDAMP4x1.3
Number of channel	4 x amplifiers channel, 2 by 2 bridgeable	
Max. output voltage (no Load)	4 x 85 Volts	4 x 135 Volts
Max. output power (4x8 Ohms)	4 x 360 Watts	4 x 750 Watts
Max. output power (4x4 Ohms)	4 x 700 Watts	4 x 1300 Watts
Max. output power (2 bridge x 8 Ohms)	2 x 1400 Watts	2 x 2600 Watts
Audio Characteristics		
Frequency response	+/-0.5dB from 20Hz to 20kHz	
Input impedance	10 kOhms	
Input sensitivity	+5 dBu	+8 dBu
Nominal Gain	32 dB	
Dynamic Range (A-weighted)	>110 dB	
THD+N	Typical 0.01%	
Back Panel Features		
Analog audio inputs	4 x balanced analog inputs on XLR	
Power outputs	4 x SP4 outputs	
Link switch	To use same XLR input for 2 adjacent channels	
Mains socket	IEC C14 Inlet with secure lock	
Front Panel Features		
Switch and knobs	Mains On/Off switch and volume control knob per channel	
View meters	4 x LEDs (signal / -18 dB / -6 dB / Peak) per channel	
Amplifier status	Amp Ready and Temperature indicator per channels pairs	
Mains Requirements		
Mains voltage	Factory set for 120 volts of 230 volts mains operation	
Power consumption (Idle)	65 Watts	
Power consumption 1/8 max. / 4 Ohms	580 Watts	900 Watts
Power consumption 1/4 max. / 4 Ohms	1100 Watts	1800 Watts
Physical Specifications		
Dimensions (W x H x D)	480 (W) x 44 (H) x 370 (D), 19 inches / 1U	
Weight	7.5kg	
Operating temperature range	0°C - 45°C	
Certifications		
CE conformity	2006/95/CE (Low voltage) 2004/108/CE (EMC) 2002/95/CE (RoHS)	
Electrical safety certification	CSA, CB, EN60065	
EMC certification	EN55103-1 / EN55103-2 / FCC	
Ordering Information		
Pre-configured for 230 volts mains	DTDAMP4x0.7C	DTDAMP4x1.3C
Pre-configured for 120 volts mains	DTDAMP4x0.7U	DTDAMP4x1.3U

AES, Dante and EtherSound network cards are available for the NXAMP. For full specifications visit nexo-sa.com