

NEXO



MSUB18

GEO M12 – MSUB18

GEO M1210 & GEO M1220 Tangent Array Modules

MSUB18 Subwoofer

 *System Manual*

GEO Technology is radically new thinking

The GEO R&D Project has, to date, resulted in the following patent applications:

The GEO Hyperboloid Reflective Wavesource™ differs radically from the megaphone-variant type horns you know and love (or hate). “Tried and true” methods will produce entirely unexpected results. HRW technology produces precise and predictable results.

The Configurable Directivity Flange. A waveguide that allows the operator to alter its behaviour. An unprecedented NEXO development that is easy to use – once you know how and when.

The Phase Directivity Device needs no operator input to function, but it is reassuring to know that the coupling of the midrange of the system is considered as important as the high frequencies...

DSP-driven Directional Sub-bass devices are a new approach to controlling LF/VLF acoustic energy.

GEO is not hard to use when you understand how...

The technology behind GEO is revolutionary, but it is grounded in years of practical experience with the problems of delivering high quality professional sound to large audiences at high SPL levels. The GEO toolbox includes NS-1 - a simple yet powerful and highly predictive design tool. The array assembly system is keyed to the design software and will easily enable you to deploy your design with great precision. NEXO Digital TDcontroller technology provide driver protection and system optimization for the GEO M and MSUB series.

GEO is a high precision system

The GEO HRW™ controls acoustic energy more precisely than other multiple element waveguides. It also makes GEO less forgiving of mistakes. Whilst conventional horns never combine into a coherent array, they may deliver acceptable results even if the design and deployment of the system is less than optimal. This is not the case with GEO where careless installation produces catastrophic results.

A GEO Tangent Array is not a “line array”

GEO Technology is equally effective in designing and deploying tangent curved vertical arrays. For best results in a specific application the user needs to know how multi-speaker arrays interact with audience geometry, along with the benefits and drawbacks of curved vertical arrays and horizontal arrays.

Curved tangent arrays require different design techniques

In the past, sound reinforcement professionals have worked with horizontal arrays that use conventional horns to deliver [more or less] ‘equal power to equal *angles*’. Curved vertical arrays are now designed to deliver [more or less] equal power to equal *areas*’. When arrays use conventional horns, the lack of precision, overlap and interference masks errors in array design and aiming. The highly precise GEO wavesource responds accurately, consistently and predictably to the design and deployment of a curved vertical tangent array. This is why the GEO rigging system is designed to control angular splay to 0.1° precision.

GEO curved tangent arrays require different operational techniques

Over the years, system designers and operators have developed a number of signal processing techniques to disguise and partly overcome the limitations of horn design. “Frequency shading,” “amplitude shading,” “High Frequency compensation”, all of these are tools of the advanced sound system operator. **NONE OF THESE TECHNIQUES ARE APPLICABLE TO GEO TANGENT ARRAYS.** Instead of enhancing the array’s performance they will severely degrade it.

Take time to learn how to get great results with GEO Technology. It is an investment that will pay off in more satisfied clients, more efficient operating procedures and more recognition for your skill as a sound system designer and operator. A comprehensive understanding of GEO theory, tangent arrays, and specific features of the GEO M Series will help you to operate your system at its full potential.

PLEASE READ CAREFULLY BEFORE PROCEEDING**BASIC PRECAUTIONS**

Do not open the speaker system or attempt to disassemble the internal parts or modify them in any way. The speaker system contains no user-serviceable parts. If it should appear to be malfunctioning or damaged, discontinue use immediately and have it inspected by qualified NEXO service personnel.

Water exposure: Do not expose the speaker system to direct rain, do not use it near water or in wet conditions. Do not place containers with liquid on speaker system as they might spill into openings. If any liquid such as water seeps into the speaker system, have it inspected by qualified NEXO personnel.

Sun exposure: Do not expose the speaker system to direct sun.

Operating temperature with temperate climate: 0°C to +40°C (-20°C to +60°C for storage).

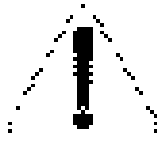
SYSTEM DEPLOYMENT SAFETY RULES

Read User Manual before deployment. Before use of enclosed speaker system, please ensure that anyone involved in system deployment understands the rigging – stacking – pole mounting safety rules as described in the speaker system User Manual. Failure to do this exposes people to potential injury or death.

Please check the web site nexo-sa.com for the latest update.

Always consult qualified NEXO personnel if the device installation requires construction work and make sure to observe the following precautions:

Mounting precautions

- choose mounting hardware and an installation location that can support 4 times the weight of the speaker system;
- do not use speaker system handles for suspended installation;
- do not expose speaker system to excessive dust or vibration, or extreme cold or heat to prevent possibility of component damage;
- do not place the speaker system in an unstable position from which it might fall accidentally;
- if speaker systems use a stand, ensure that stand specifications are adapted, and that stand height does not exceed 1.40m/55"; never move the stand while the speaker is in position.
- in case of wind greater than 8 on Beaufort scale (72km/h – 45mph), a touring system has to be landed or an additional securing has to be implemented.
- for fixed installations, wind loading has to be taken into account in accordance to the national standards.

Connection and powering precautions

- remove all connected cables before moving the speaker system;
- turn off AC power of all power amplifier units before connecting the speaker system;
- when turning on the AC power to the audio system, always turn on the power amplifier last; when turning the AC power off, always turn off the power amplifier first;
- when used in cold conditions, a gradual power ramp up should be applied to the system on an 5 mn period to allow the loudspeaker components to stabilize during the very first minutes of usage.

Inspect the speaker system periodically.

HIGH SOUND PRESSURE LEVELS



Exposure to extremely high noise levels may cause permanent hearing loss. Individuals vary considerably in susceptibility to noise-induced hearing loss but nearly everyone will lose some hearing if exposed to sufficiently intense noise for a sufficient period of time. The U.S. Government’s Occupational and Health Administration (OSHA) has specified the following permissible noise level exposures: Sound Duration Per

Day In Hours	Sound Level dBA, Slow Response
8	90
6	92
4	95
3	97
2	100
1 ½	102
1	105
½	110
¼ or less	115

According to OSHA, any exposure in excess of the above permissible limits could result in some hearing loss. Ear plugs or protectors to the ear canals or over the ears must be worn when operating this amplification system in order to prevent permanent hearing loss, if exposure is in excess of the limits as set forth above. To ensure against potentially dangerous exposure to high sound pressure levels, it is recommended that all persons exposed to equipment capable of producing high sound pressure levels such as this amplification system be protected by hearing protectors while this unit is in operation.

DISPOSAL OF OLD ELECTRICAL & ELECTRONIC EQUIPMENT



This symbol on the product or on its packaging indicates that it shall not be treated as household waste. Instead it shall be handed over to the applicable collection point for the recycling of electrical and electronic equipment. By ensuring this product is disposed of correctly, you will help prevent potential negative consequence for the environment and human health, which could otherwise be caused by inappropriate waste handling of this product. The recycling of materials will help to conserve natural resources. For more detailed information about recycling of this product, please contact your local city office, your household waste disposal service or the shop where you purchased the product.



CONTENTS

PLEASE READ CAREFULLY BEFORE PROCEEDING	3
CONTENTS	5
1 INTRODUCTION	7
2 GEO M12 GENERAL SET-UP INSTRUCTIONS	8
2.1 GEO M12 AND MSUB18 CONNECTIONS.....	8
2.1.1 <i>GEO M12 connectors</i>	8
2.1.2 <i>MSUB18 connectors</i>	8
2.2 GEO M12-I AND MSUB18-I CONNECTIONS.....	9
2.2.1 <i>GEO M12-I connectors</i>	9
2.2.2 <i>MSUB18-I connectors</i>	10
2.3 CABLING	11
2.4 GEO M12 & MSUB18 RECOMMENDED AMPLIFICATION	11
2.5 GEO M12 & MSUB18 SETUPS ON NEXO TD CONTROLLERS	11
3 CONNECTION DIAGRAMS.....	12
3.1 GEO M12 (PASSIVE MODE) / NXAMP4x1MK2 (BRIDGE STEREO)	12
3.2 MSUB18 / NXAMP4x1MK2 (BRIDGE STEREO)	12
3.3 GEO M12 (PASSIVE MODE) AND MSUB18 / NXAMP4x1MK2 (BRIDGE STEREO)	13
3.4 GEO M12 (PASSIVE MODE) / NXAMP4x2MK2	14
3.5 MSUB18 / NXAMP4x2MK2	14
3.6 GEO M12 (PASSIVE MODE) AND MSUB18 / NXAMP4x2MK2	15
3.7 GEO M12 (PASSIVE MODE) / NXAMP4x4	16
3.8 GEO M12 (ACTIVE MODE) / NXAMP4x4	17
3.9 MSUB18 OMNI MODE / NXAMP4x4	18
3.10 MSUB18 CARDIO MODE / NXAMP4x4	19
3.11 GEO M12 (PASSIVE MODE) AND MSUB18 / NXAMP4x4	20
4 NS-1 SIMULATION SOFTWARE	21
5 CONFIGURABLE DIRECTIVITY DEVICE	22
5.1 INSTALLING & REMOVING GEO'S CONFIGURABLE DIRECTIVITY DEVICES	22
5.2 WHEN & WHERE TO USE CONFIGURABLE DIRECTIVITY FLANGES.....	23
6 GEO M12 HARDWARE SETUP PROCEDURE.....	24
6.1 SAFETY FIRST.....	24
6.1.1 <i>Flown Systems Safety</i>	24
6.1.2 <i>Ground Stacking Safety</i>	25
6.1.3 <i>Contacts</i>	26
6.2 GENERAL DESCRIPTION	27
6.2.1 <i>GEO M1210 and GEO M1220</i>	27
6.2.2 <i>GEO M12 "Left" and "Right" configuration</i>	27
6.2.3 <i>GEO M12 and MSUB18 rigging systems</i>	27
6.2.4 <i>GEO M12-I and MSUB18-I rigging systems</i>	29
6.2.5 <i>Accessories</i>	29
6.2.6 <i>Warnings on GEO M12 & MSUB18 accessories</i>	30
6.3 GROUND STACK SETUPS.....	31
6.3.1 <i>Described configurations</i>	31
6.3.2 <i>GEO M12 only on Lightweight Bumper</i>	32
6.3.3 <i>GEO M12 only on Touring Bumper with stacking extensions</i>	35

6.3.4	<i>MSUB18 and GEO M12 with Ministack adaptor</i>	38
6.3.5	<i>MSUB18 and GEO M12 on Touring Bumper with stacking extensions</i>	41
6.4	FLOWN CLUSTERS SETUPS	45
6.4.1	<i>Described configurations</i>	45
6.4.2	<i>GEO M12 only flown with Lightweight Bumper</i>	46
6.4.3	<i>GEO M12 flown with Touring Bumper</i>	50
6.4.4	<i>MSUB18 flown with Touring Bumper</i>	54
6.4.5	<i>MSUB18 and GEO M12 flown with Touring Bumper</i>	57
6.5	PERMANENT INSTALLATION VARIANT	62
6.6	TESTING AND MAINTENANCE OF THE SYSTEM.....	65
7	SYSTEM CHECK ALIGNMENT GUIDELINES	66
7.1	GEO M12 VERTICAL CLUSTER DESIGN.....	66
7.2	STACKED MSUB18 AND FLOWN GEO M12	66
7.3	DRIVING THE MSUB18S FROM THE AUX SEND.....	67
7.4	RECOMMENDED INSTALLATION TOOLS AND EQUIPMENT	67
7.5	GEO M12 – MSUB18 SYSTEM CHECK LIST	68
8	TECHNICAL SPECIFICATIONS	69
8.1	MSUB18 SUBWOOFER	69
8.1.1	<i>System specifications</i>	69
8.1.2	<i>Dimensions (mm/inches)</i>	69
8.2	GEO M1210 & GEO M1220	70
8.2.1	<i>System specifications</i>	70
8.2.2	<i>Dimensions (mm/inches)</i>	70
8.3	GEO M12 ACCESSORIES	71
8.3.1	<i>VNT-BUMPM12</i>	71
8.3.2	<i>VNI-BUMPM12</i>	72
8.3.3	<i>VNT-EXBARM12</i>	73
8.3.5	<i>VNT-GSTKM10M12L</i>	74
8.3.6	<i>VNT-GSTKM10M12S</i>	75
8.3.7	<i>VNT-MNSTKM12</i>	76
8.3.8	<i>GMT-LBUMPM12</i>	77
8.3.9	<i>GMT-EXBARM12L</i>	78
8.3.10	<i>GMT-FLGM12</i>	79
8.3.11	<i>MST-WBMSUB18</i>	80
8.3.12	<i>MST-DOLLYMSUB18</i>	81
8.3.13	<i>MST-COVMSUB18</i>	82
8.3.14	<i>MST-COV2MSUB18</i>	83
8.3.15	<i>GMT-2CASEM12</i>	84
8.3.16	<i>GMT-3CASEM12</i>	85
8.3.17	<i>VNT-LSTKM1018</i>	86
9	GEO M12 & MSUB18 MODULES & ACCESSORIES LIST	87
10	USER NOTES	90

1 INTRODUCTION

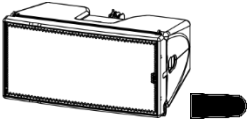
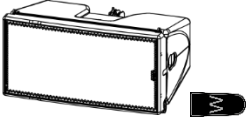
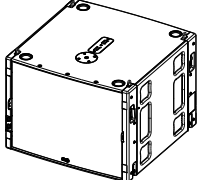
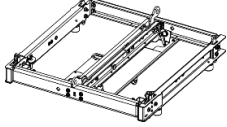
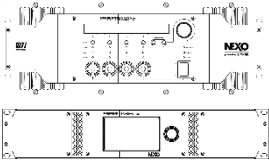
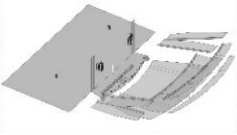
Thank you for selecting a NEXO GEO M12 Series Tangent Array System. This manual is intended to provide you with necessary and useful information about your GEO M12 & MSUB18 System, which includes the following products:

	<ul style="list-style-type: none"> GEO M1210 is a 10° Tangent Array Module. It comprises 1x12" (30cm) 8 ohms long excursion Neodymium LF/MF driver loaded by a Phase Directivity Device (PDD™) and 1x1.4" throat 16 Ohm HF Neodymium driver loaded by a 5° Hyperboloid Reflective Wavesource (HRW™). GEO M1210 is available in touring and installation versions.
	<ul style="list-style-type: none"> GEO M1220 is a 20° Tangent Array Module. It comprises 1x12" (30cm) 8 ohms long excursion Neodymium LF/MF driver loaded by a Phase Directivity Device (PDD™) and 1x1.4" throat 16 Ohm HF Neodymium driver loaded by a 15° Hyperboloid Reflective Wavesource (HRW™). GEO M1220 is available in touring and installation versions.
	<ul style="list-style-type: none"> MSUB18 is GEO M12 companion subwoofer. It comprises 1x18" (38cm) long excursion Neodymium driver and features very high efficiency as well as high acoustic output. MSUB18 has fittings for transporting, flying and stacking. MSUB18 is available in touring and installation versions.
	<ul style="list-style-type: none"> A full range of accessories provides safe, flexible and simple means of installing GEO M12 and MSUB18 in fixed installation as well as in touring applications.
	<ul style="list-style-type: none"> GEO M12 and MSUB18 are controlled, powered and monitored by NEXO TDcontrollers. For a complete description of these controllers, please refer to User Manuals. NEXO TDcontrollers DSP algorithms and parameters are fixed in software and updated regularly. Please consult the NEXO web site (nexo-sa.com) for the latest software releases.
	<ul style="list-style-type: none"> NS-1 simulation software assists in the design and implementation of vertical tangent GEO arrays. Please consult the NEXO web site (nexo-sa.com) for the latest software releases.
	<ul style="list-style-type: none"> Available for Mac, iPad and iPhone, NEXO NeMo provides full remote control over a digital audio network from anywhere in the venue, thanks to an intuitive and graphically attractive user interface. NeMo is available on Apple App Store.

Please devote your time and attention to reading this manual. A comprehensive understanding of GEO M12 and MSUB18 specific features will help you to operate your system at its full potential.

2 GEO M12 GENERAL SET-UP INSTRUCTIONS

2.1 GEO M12 and MSUB18 connections

GEO M12 and MSUB18 are connected with Speakon NL4FC plugs (not supplied). A wiring diagram is printed on the connection panel located on the back of each cabinet. The 4 pins of the Speakon sockets identified in / out are connected in parallel within the enclosure.

Either connector can be used to connect amplifier or to link to an additional GEO M12 cabinet or to link to an optional MSUB18 (if present). Therefore, a single 4-conductor cable can connect two amplifier channels to various GEO M12s and/or MSUB18 subwoofers.

2.1.1 GEO M12 connectors

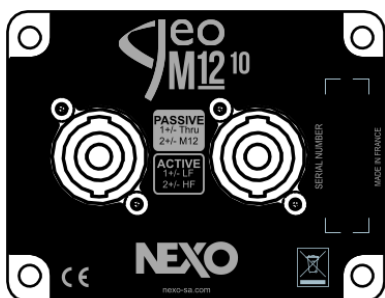

Selection of Active or Passive Mode



Speakon Connector	M1210 & M1220	
	Passive Mode	Active Mode
1(-) ⇨	Through	GEO M12 LF (-)
1(+) ⇨	Through	GEO M12 LF (+)
2(-) ⇨	GEO M12 (-)	GEO M12 HF (-)
2(+) ⇨	GEO M12 (+)	GEO M12 HF (+)

2.1.2 MSUB18 connectors

MSUB18 features 2 connector panels with 2 Speakon NL4 each so that cabling is always done at the back independently of cabinet being set frontwards or rearwards for cardioid configurations.

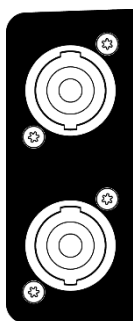

Speakon Connector	MSUB18
1(-) ⇨	MSUB18 (-)
1(+) ⇨	MSUB18 (+)
2(-) ⇨	Through
2(+) ⇨	Through

2.2 GEO M12-I and MSUB18-I connections

2.2.1 GEO M12-I connectors

GEOM12-I are connected through 2 captive cables and 2 fast connectors.

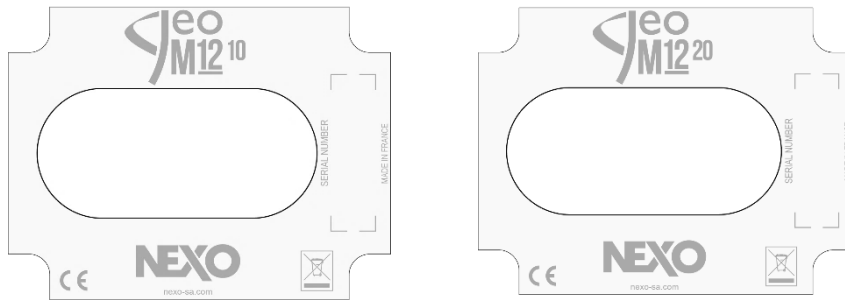

In order to connect for installation:

- Remove the connecting plate.
- Pass the cables through the cable-gland (maximum cable outside diameter is 12mm / 0.5", maximum gauge wire is 2.5 mm² / AWG13 for solid cable and 4 mm² / AWG11 for multi-stranded cable)
- Prepare cable as below

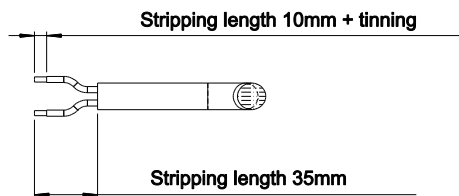

- Connect to the fast connectors (+): Brown (or Red) / (-): Blue (or Black).
- Remount the connecting plate.
- Tight the cable-gland and adjust the length.
- Seal the cabinet with the provided blind plug on the unused cable gland.

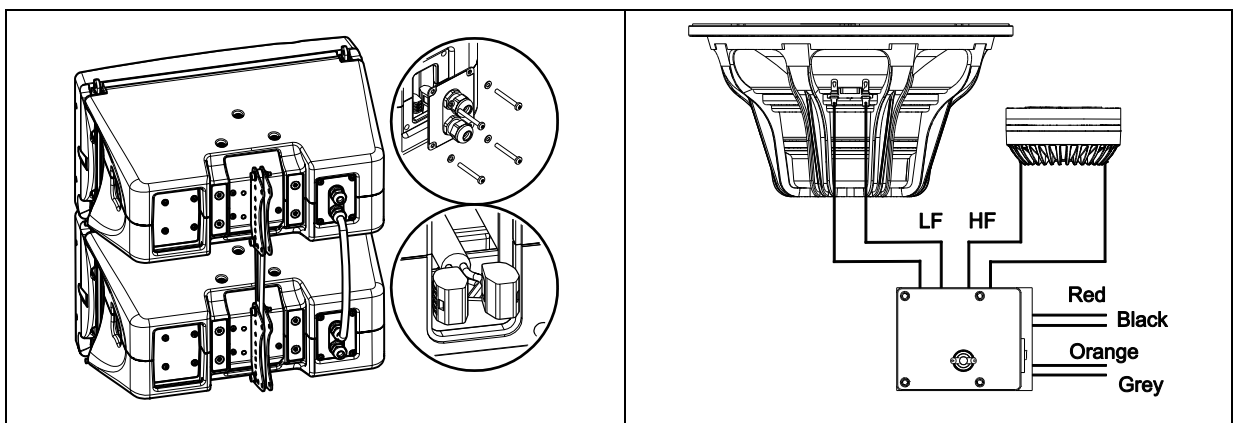

2.2.2 MSUB18-I connectors

MSUB18-I are connected through 2 fast connectors located behind the corner plates as in drawing below.

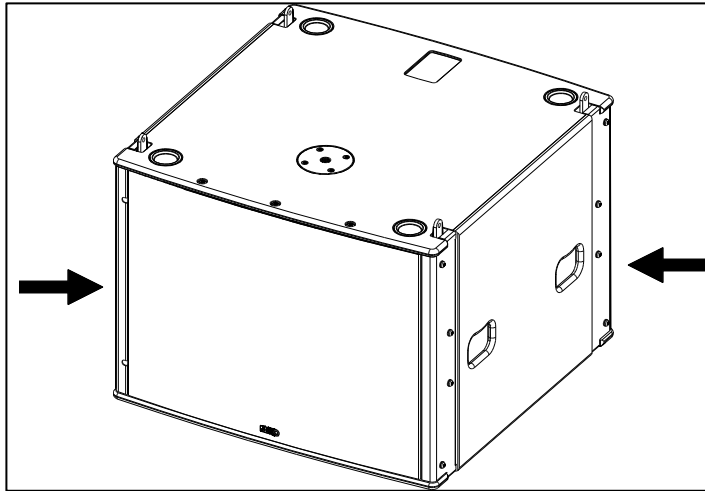

In order to connect for installation:

- Remove the corner plates.
- Pass the cables through corner plate openings (maximum cable outside diameter is 11mm / 0.4", maximum gauge wire is 2.5 mm² / AWG13 for solid cable and 4 mm² / AWG11 for multi-stranded cable)
- Prepare cable as below

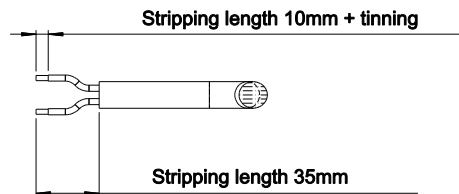

- Connect to the fast connectors (+): Brown (or Red) / (-): Blue (or Black).
- Remount the corner plate.

2.3 Cabling

NEXO recommends the exclusive use of multi-conductor cables to connect the system: the cable kit is compatible with all the cabinets, and there is no possible confusion between LF, MF and HF sections.

Cable choice consists mainly of selecting cables of the correct sectional dimension (size) in relation to the load resistance and the cable length. Too small a cable section will increase both its serial resistance and its capacitance; this reduces the electrical power delivered to the loudspeaker and can also induce response (damping factor) variations.

For a serial resistance less or equal to 4% of the load impedance (damping factor = 25), the recommended cable length is given by:

$$L_{\max} = Z \times S \quad S \text{ in mm}^2, Z \text{ in Ohm, } L_{\max} \text{ in meters}$$

The table below indicates these values, for 3 common sizes.

Load Impedance (Ω)	2	3	4	6	8
Cable section	Recommended Cable Length				
1,5 mm ² (AWG #14)	3m/10ft	4.5m/13ft	6m/20ft	9m/30ft	12m/39ft
2,5 mm ² (AWG #12)	5m/16ft	7.5m/23ft	10m/33ft	15m/49ft	20m/66ft
4 mm ² (AWG #10)	8m/26ft	12m/39ft	16m/52ft	24m/79ft	32m/105ft

Maximum allowed length is 4 times recommended length.

Example:

GEO M12 module has a 8 Ω nominal impedance in passive mode. When connecting 4 modules in parallel, total load impedance become 2 Ω .

Recommended length for 4mm² / (AWG#10) is 8m / 26ft, maximum allowed length is 32m / 105ft.

IMPORTANT

Long speaker cables induce capacitive effects – up to hundreds of pF depending on the quality of the cable - with a low-pass effect on high frequencies. If long speaker cables must be used, ensure that they do not remain coiled while in use.

2.4 GEO M12 & MSUB18 recommended amplification

NEXO TD Controllers	Recommended amplification
NXAMP4x1mk2 Powered Controller Bridged Stereo mode (2x2.6kW/4 Ω)	2 x GEO M12 in passive mode per bridged channel 1 x MSUB18 per bridged channel
NXAMP4x2mk2 Powered Controller 4 channels mode (4x2.5kW/2 Ω)	1 x GEO M12 in passive mode per channel 1 x MSUB18 per channel
NXAMP4x4 Powered Controller 4 channels mode (4x4kW/2 Ω)	3 x GEO M12 in passive mode per channel 3 x GEO M12 in active mode: 2 channels 2 x MSUB18 per channel

2.5 GEO M12 & MSUB18 setups on NEXO TD Controllers

Please consult nexo-sa.com for NEXO TD Controllers firmware information.

3 CONNECTION DIAGRAMS

3.1 GEO M12 (passive mode) / NXAMP4x1mk2 (Bridge Stereo)

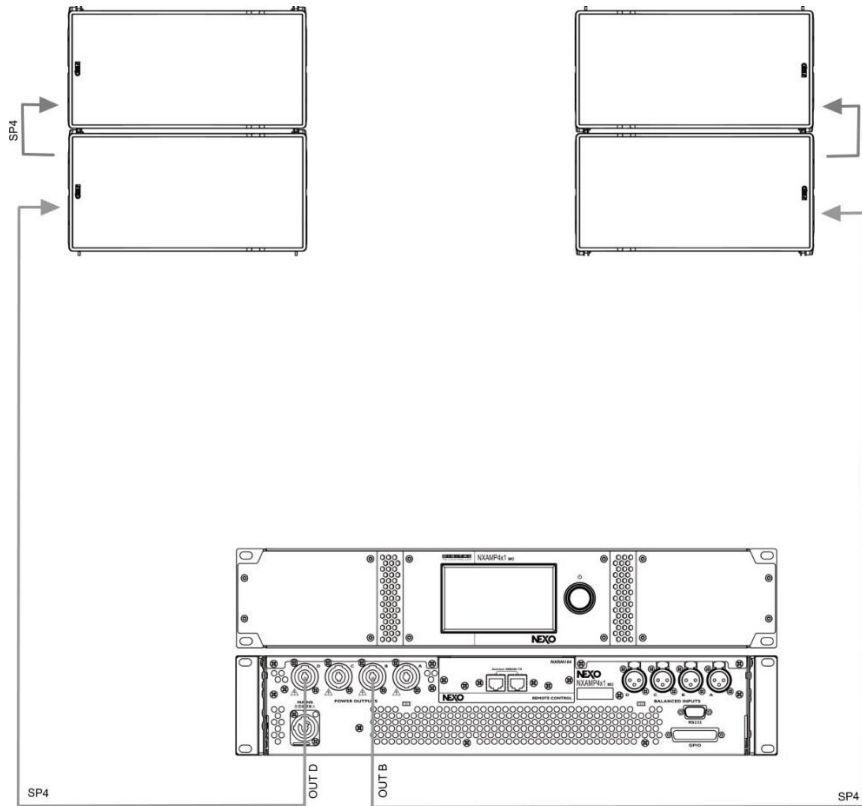

3.2 MSUB18 / NXAMP4x1mk2 (Bridge Stereo)

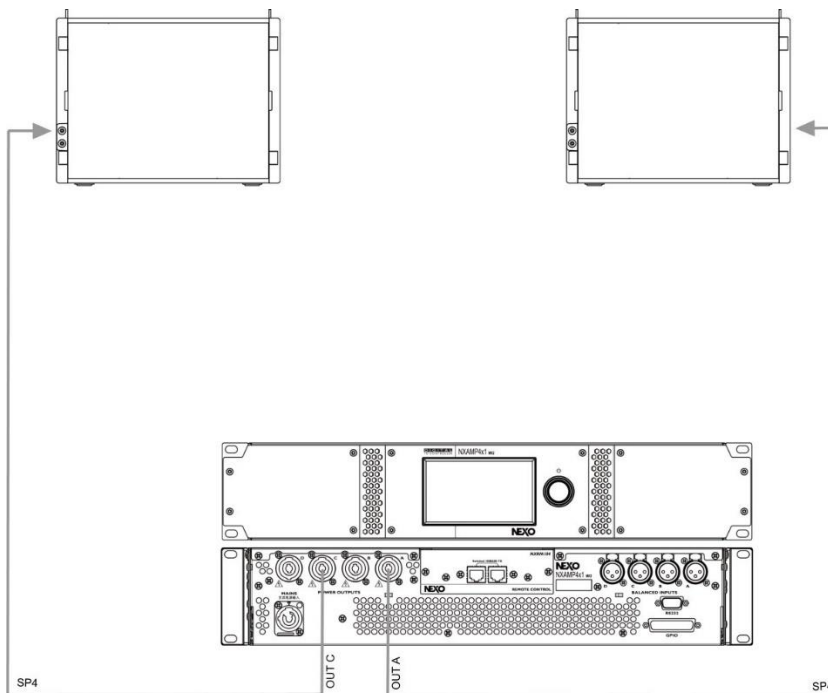

3.3 GEO M12 (passive mode) and MSUB18 / NXAMP4x1mk2 (Bridge Stereo)

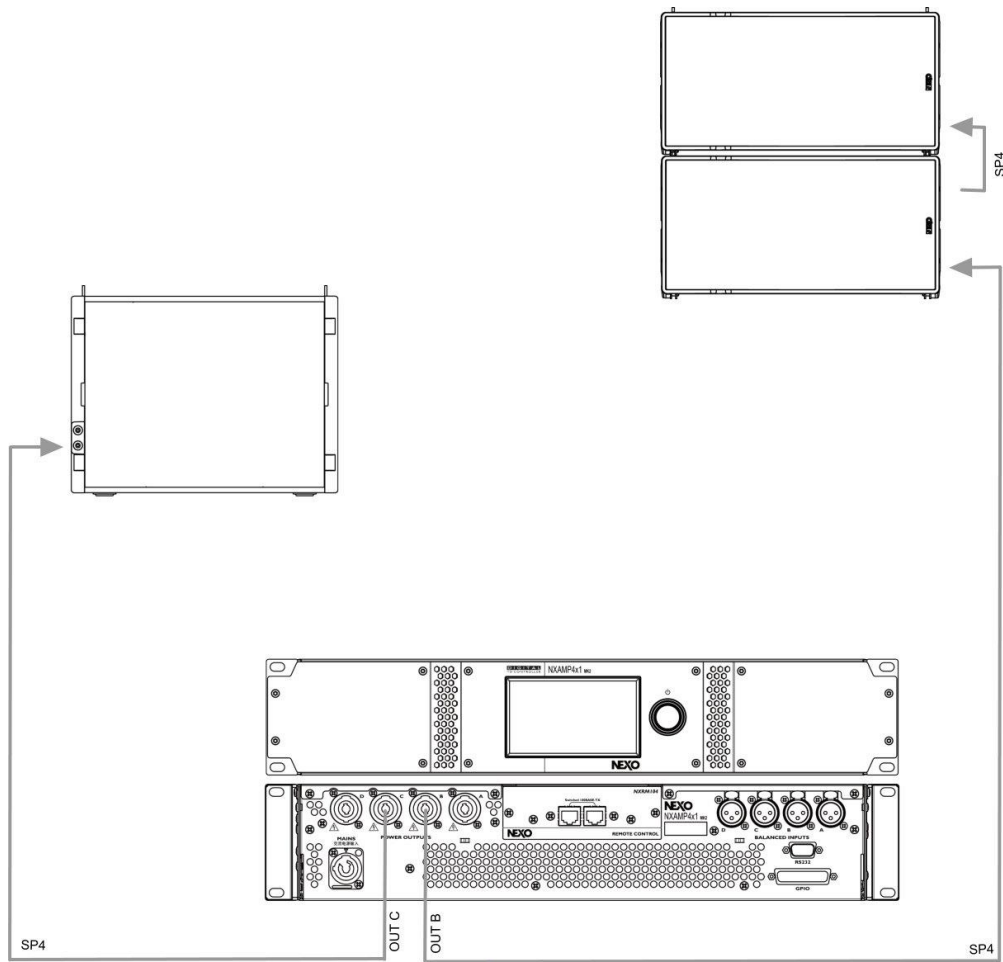

3.4 GEO M12 (passive mode) / NXAMP4x2mk2

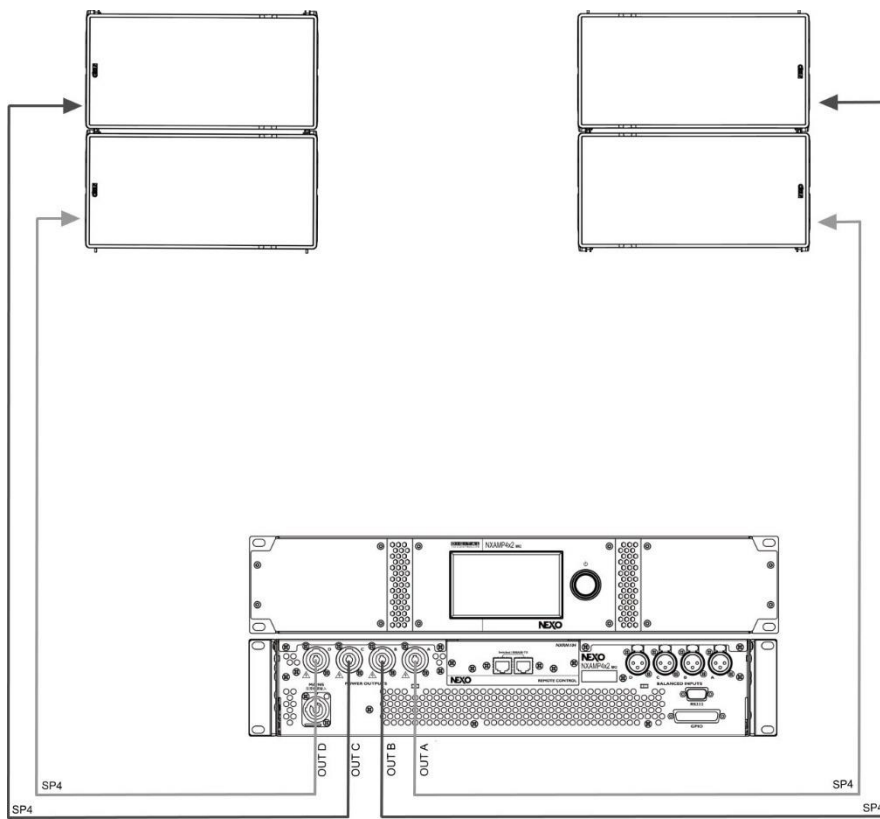

3.5 MSUB18 / NXAMP4x2mk2

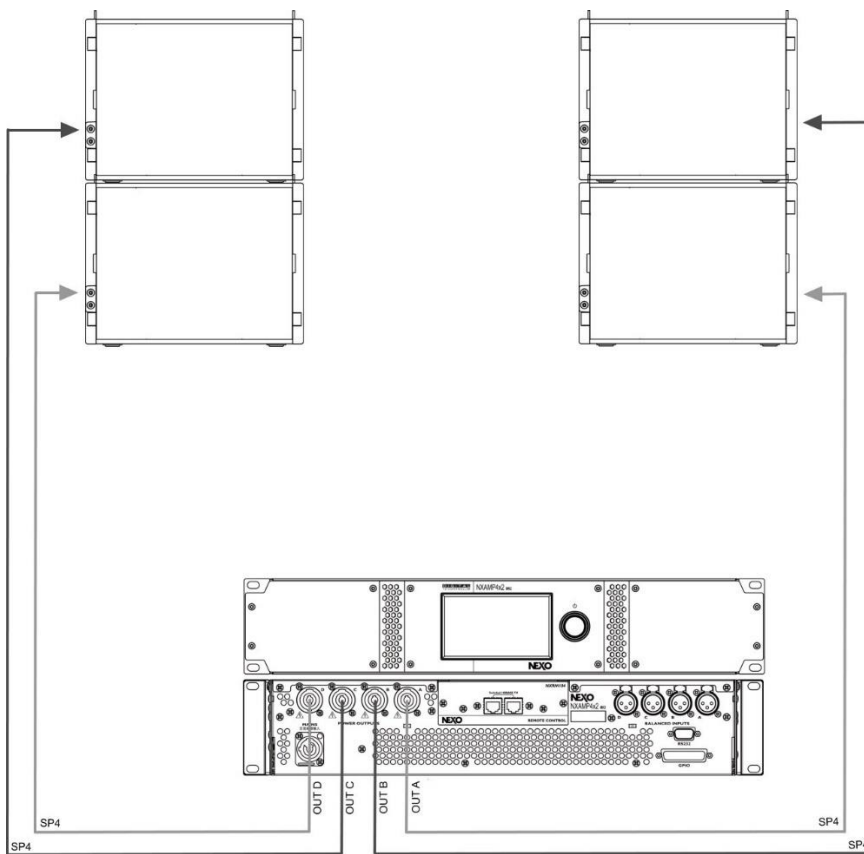

3.6 GEO M12 (passive mode) and MSUB18 / NXAMP4x2mk2

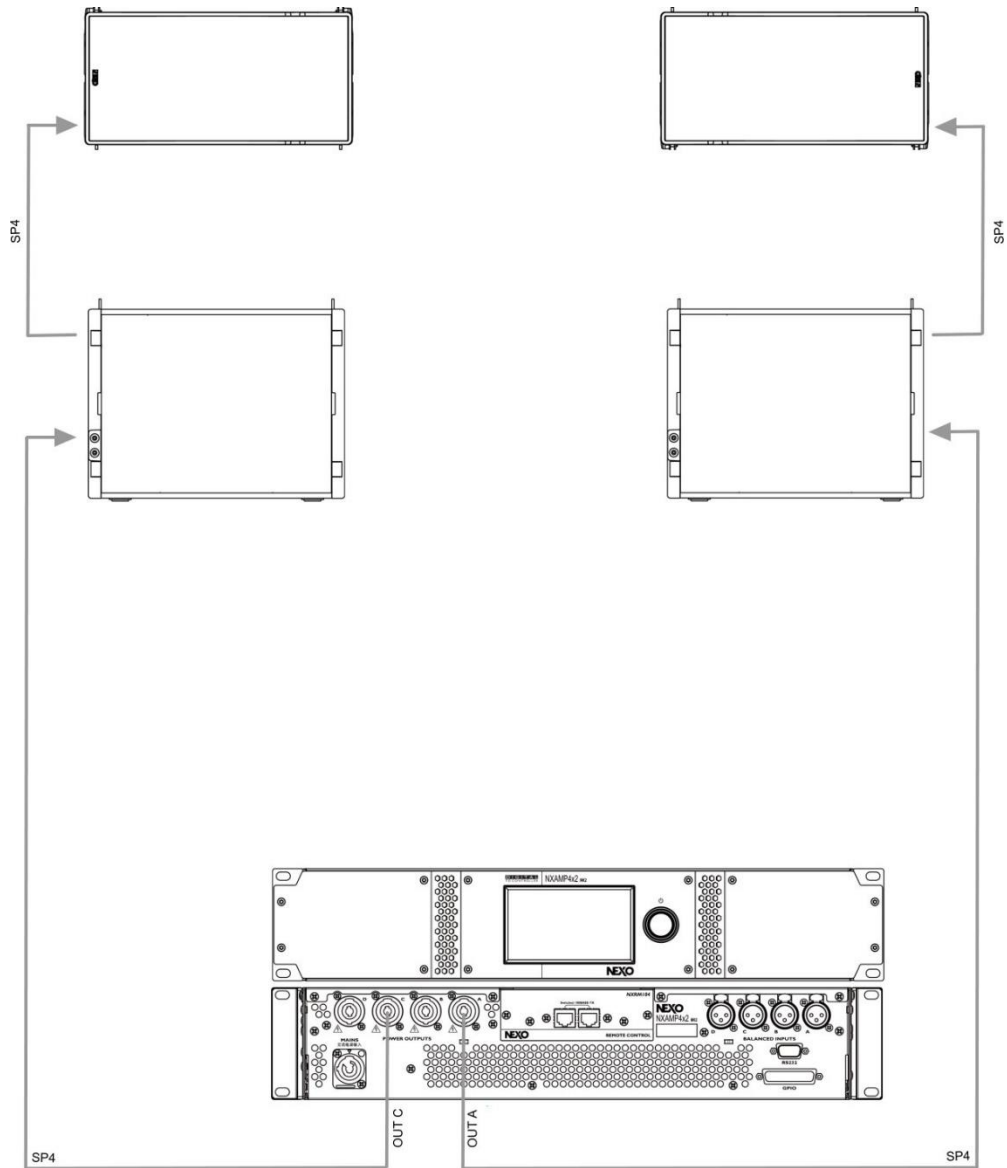

3.7 GEO M12 (passive mode) / NXAMP4x4

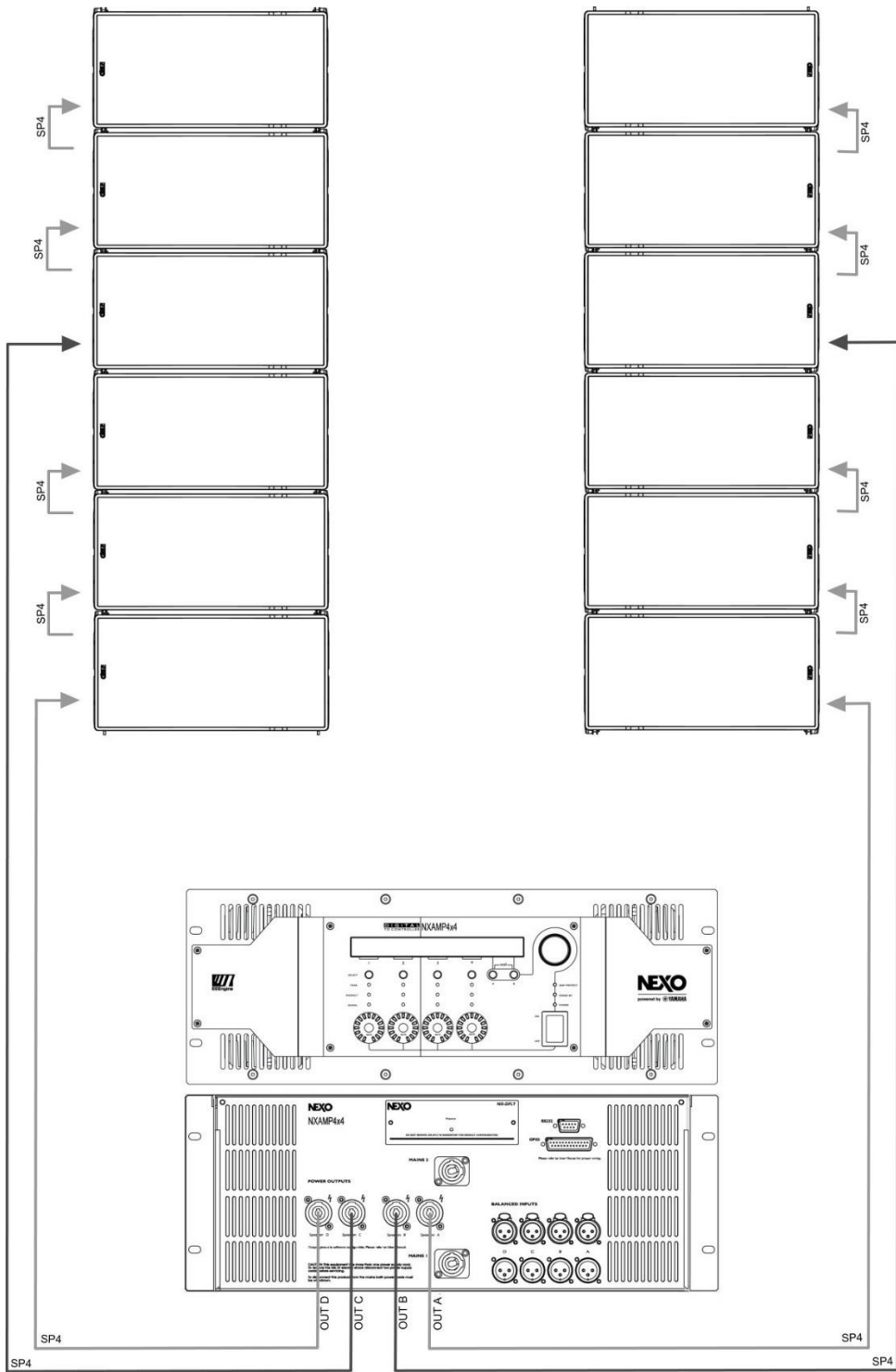

3.8 GEO M12 (active mode) / NXAMP4x4

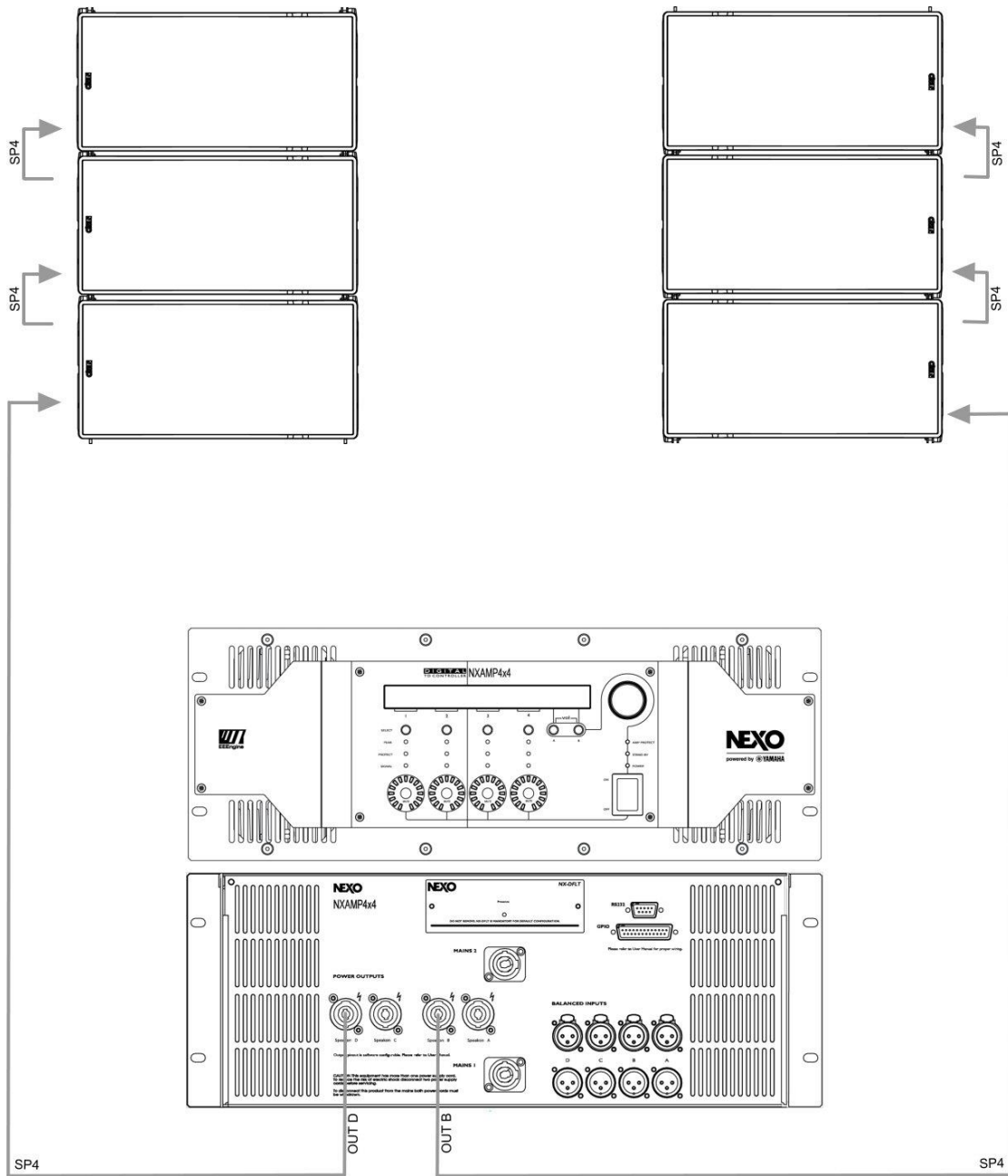

3.9 MSUB18 Omni Mode / NXAMP4x4

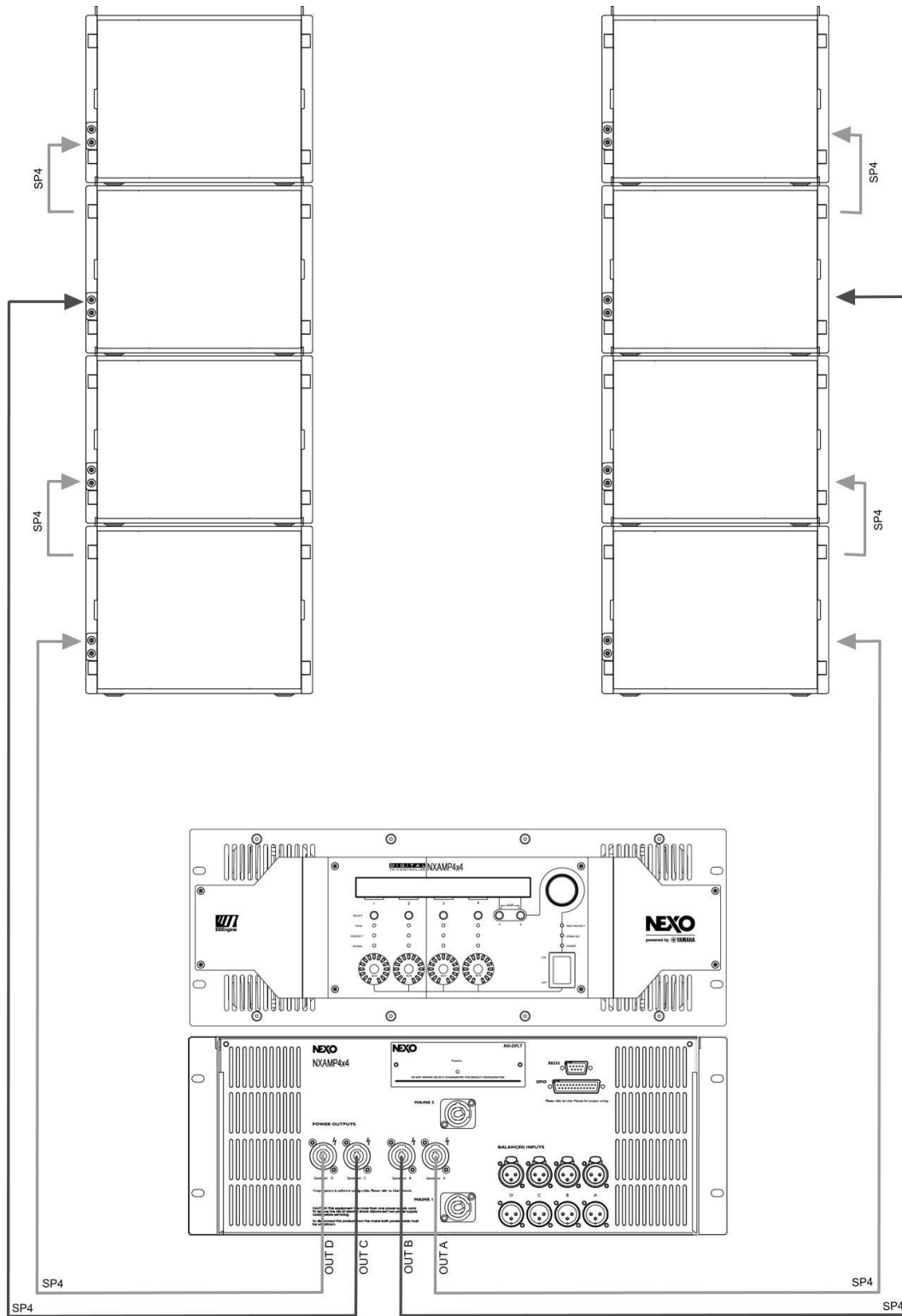

3.10 MSUB18 Cardio Mode / NXAMP4x4

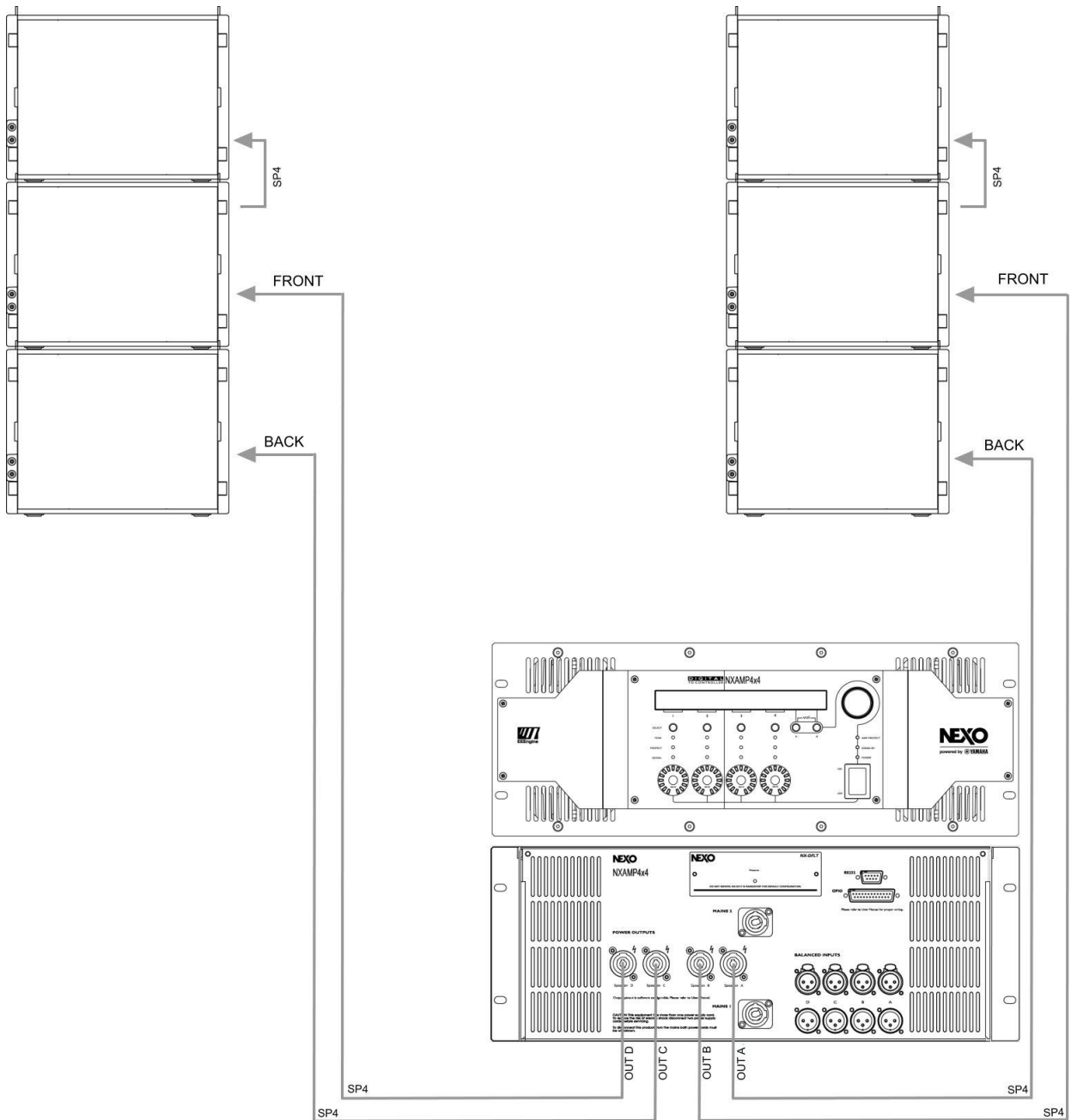

3.11 GEO M12 (passive mode) and MSUB18 / NXAMP4x4

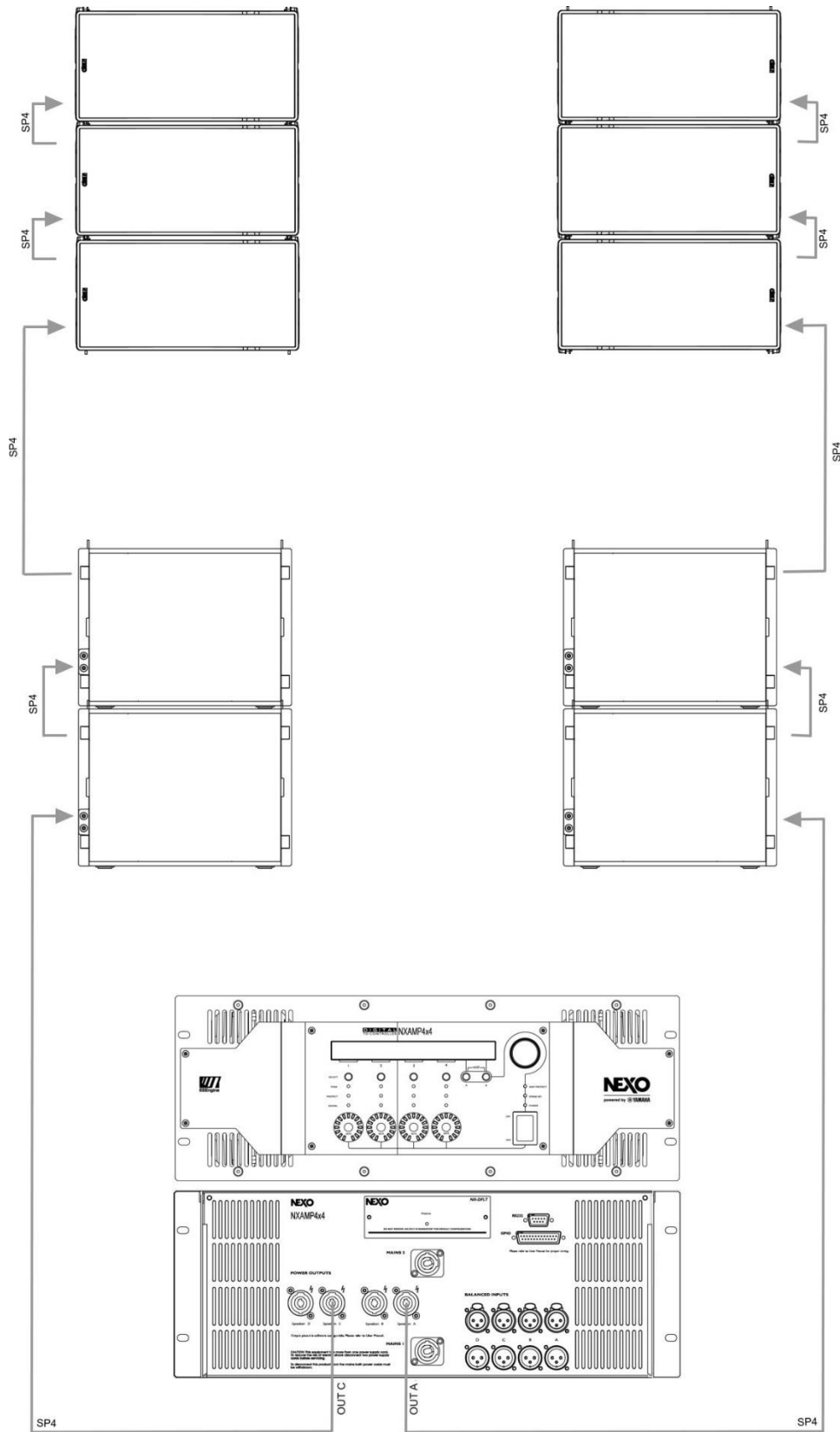

4 NS-1 SIMULATION SOFTWARE

NS-1 software is a R&D simulation tool derived application. It processes measured speaker data with complex mathematical algorithms to assist the user in optimizing system design. Due to the complexity of the interaction of multiple cabinets, it is simply not possible to reliably design curved vertical arrays without using the processing power of a computer to predict the optimum array structure for a given audience geometry. The design logic is far more complex than looking at a section drawing of the venue, measuring the overall angle needed to cover the audience from the cluster location, and dividing by 10 degrees to determine the required amount number of GEO M1210 cabinets.

NS-1 is an easy to use tool that allows to shape the energy leaving the cluster to fit the audience. It predicts pressure levels radiated from the system to ensure enough cabinets are provided for the application, as well as mechanical constraints for safe flown systems.

In addition, it provides mechanical information for all clusters in agreement with Structural Analysis Reports (available in the Help section): dimensions, weight, gravity centre position, forces, moments, working load and safety factor.

GEO M12 and MSUB18 Structural Analysis Report is currently being certified by German Certification Organization RWTUV systems GmbH.

NS-1 installation package includes all NEXO User Manuals, Structural Analysis Reports and Certificates PDF files (which can be found in the last section of User Manuals).

NS-1 is a freeware available on nexo-sa.com

IMPORTANT

Never install a GEO M12 and/or MSUB18 cluster without checking its acoustical performances and mechanical safety in NS-1 prior to installation.

Any question or bug report please contact technical@nexo.fr

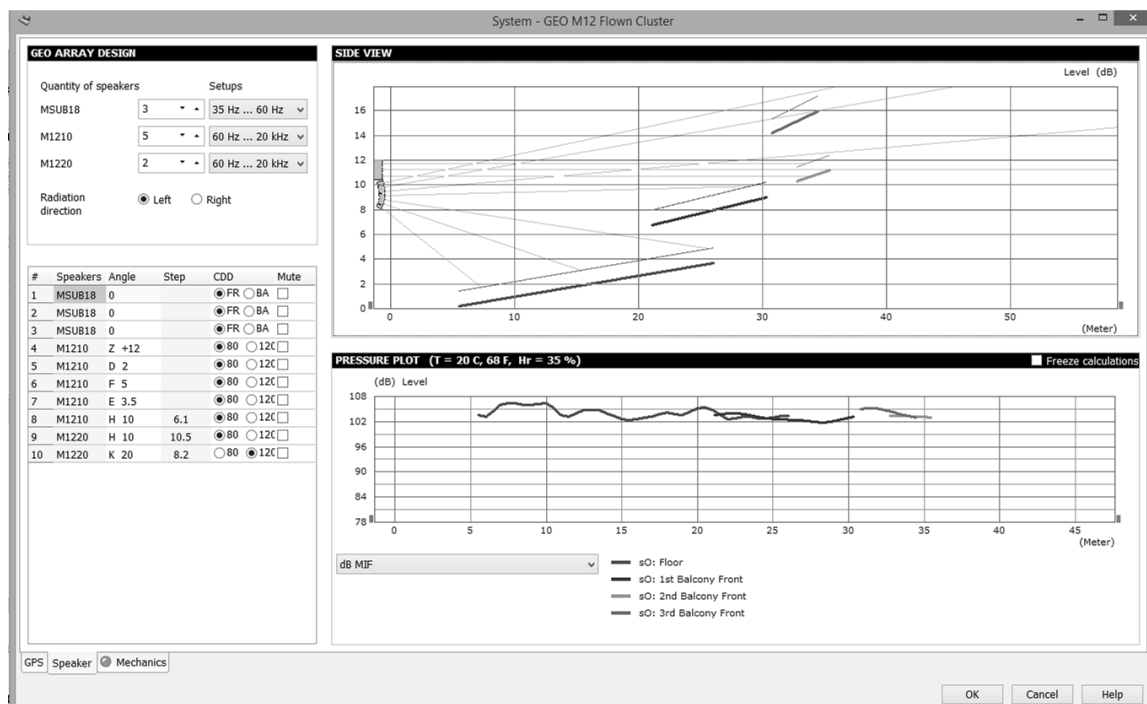

5 CONFIGURABLE DIRECTIVITY DEVICE

The GEO Wavesource controls dispersion of acoustic energy using a hyperboloid acoustical reflector in the “coupling plane” (the vertical plane of a curved vertical tangent array) and a diffraction slot in the “non-coupling plane” (the horizontal plane of a curved vertical tangent array). The patented Configurable Directivity Device consists of flanges that alter the diffraction slot’s exit flare rate.

5.1 Installing & removing GEO’s Configurable Directivity Devices

GEO M12 are shipped in the 80° dispersion configuration, 120° CDD™ flanges are an optional accessory (GMT-FLGM12).

To change horizontal dispersion from 80° to 120° and vice-versa:

- Pull the lever to remove the grille on the side on touring version
- Or unscrew the 4 Tx25 to remove the grille on installation version
- Position the CDD™ flanges on (or remove them from) the waveguide output magnetic clips;
- Reinstall the grille and lock it with the lever (touring version) or the screws (installation version)

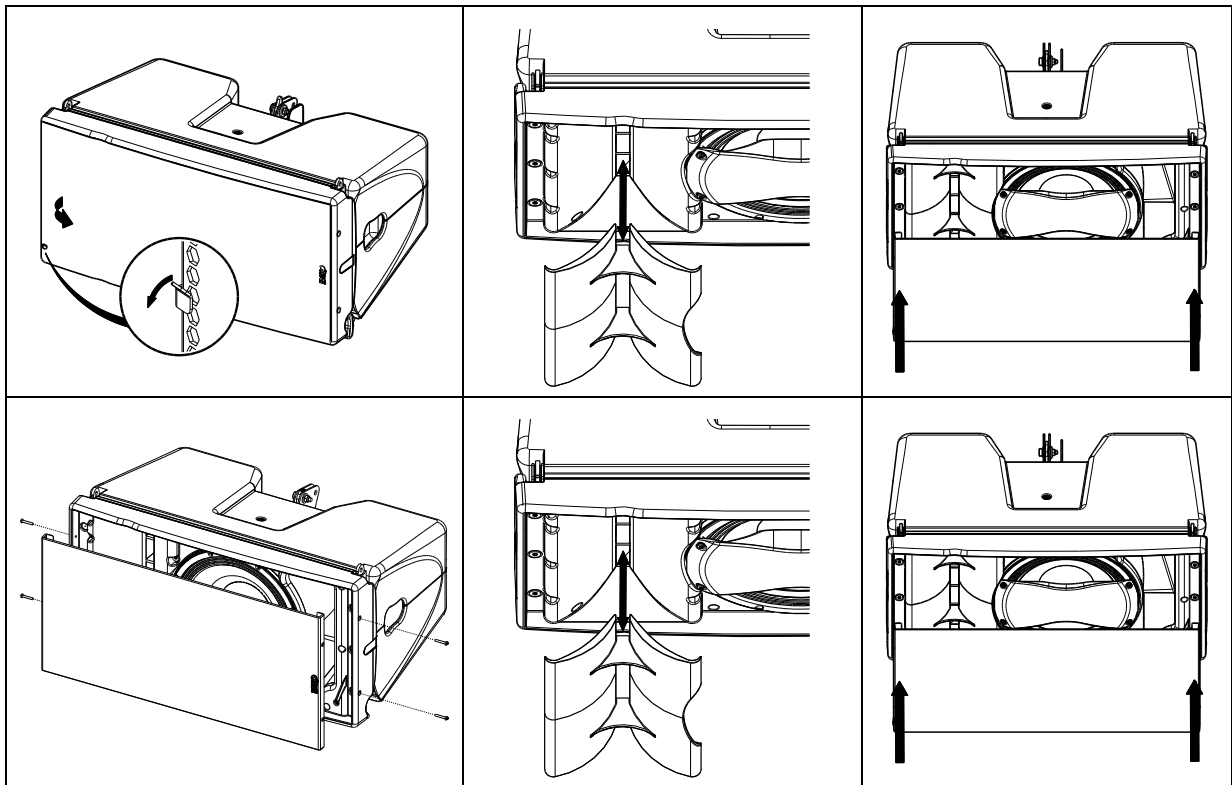

5.2 When & where to use Configurable Directivity flanges

The diagrams show audience area coverage for a stereo system. While the GEO cluster will deliver even SPL from the front to the rear of this audience area, there are “holes” near the front in the centre and at the outside edges. We cannot fill the outside coverage gaps without enlarging the centre gap, and vice versa (left figure below).

If 120° Configurable Directivity Devices are installed at the bottom cabinet of the clusters, coverage will look more like the pattern in right figure below.

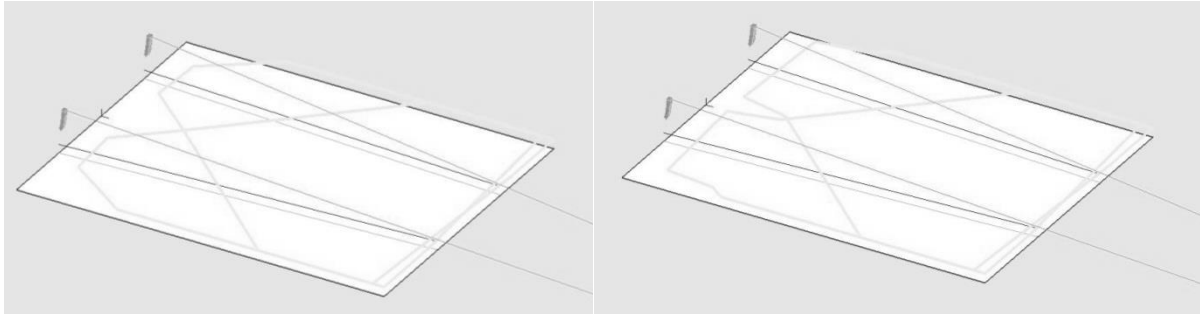

-6dB coverage, all GEO M12 in 80° configuration

-6dB coverage, bottom GEO M12 in 120° configuration

In curved vertical arrays, the 120° Configurable Directivity Device can be used:

- On the bottom row of curved vertical arrays, to fill in coverage gaps in the front rows.
- On all rows of curved vertical arrays, in cases where 120° of horizontal coverage is preferred to 80°.

IMPORTANT

Installing or removing one of the two flanges anticipating asymmetrical coverage will degrade both coverage and frequency response.

6 GEO M12 HARDWARE SETUP PROCEDURE

Before proceeding with assembly of GEO M12 & MSUB18 arrays, please ensure that the components are present and undamaged. A component list is appended to this manual. In the event of any shortage, please contact your supplier.

For maximum efficiency the GEO M12 & MSUB18 rigging system requires three experienced persons for set-up: typically, one motor hoist operator, and one operator per side of the array. Good synchronisation and crosscheck between the operators are key elements for a reliable and safe set-up.

6.1 SAFETY FIRST

GEO M12 & MSUB18 Rigging System structural computations and related documents are available in NS-1 or at NEXO (info@nexo.fr) upon request.

We include this section to remind you of safe practice when flying the GEO M12 & MSUB18 system. Please read it carefully. However, user must always apply his or her knowledge, experience and common sense. If in any doubt, seek advice from your supplier or NEXO agent.

This manual offers guidance only for GEO M12 & MSUB18 loudspeaker systems. References in this manual to other rigging equipment such as motor hoists, steels, shackles etc. are made to clarify the description of rigging procedures. The user must ensure that operators are properly trained by other agencies in the use of these items.

The GEO M12 & MSUB18 Rigging System has been optimised for the deployment of curved vertical tangent arrays of GEO M12 & MSUB18 loudspeakers. Angle adjustment between cabinets has been limited to specific settings to ensure correct acoustic coupling.

The GEO M12 & MSUB18 Rigging System is a professional precision tool set, and should be handled with extreme care. Only persons who are fully conversant with the operation of the GEO M12 & MSUB18 Rigging System and provided with suitable safety equipment should deploy GEO Arrays. Misuse of the GEO M12 & MSUB18 Rigging System could lead to dangerous consequences.

Used and maintained correctly, the GEO M12 & MSUB18 Rigging System will give many years of reliable service in portable systems. Please take the time to read and understand this manual. Always use NS-1 to determine the optimum angle settings for a particular venue, hang point and curved vertical GEO M12 & MSUB18. Applied forces and moments are strongly cabinet quantity and angle configuration dependent. Cluster configuration must be implemented and validated in NS-1 prior to installation.

6.1.1 Flown Systems Safety

Always inspect all the rigging components and cabinets for damage before assembly. Pay special attention to the lifting points, and safety clips. If you suspect that any of the components are damaged or defective, DO NOT USE THE AFFECTED PARTS. Contact your supplier for replacements.

Read this manual carefully. Also, be familiar with the manuals and safe working procedures for any ancillary equipment that will be used with the GEO M12 & MSUB18 Rigging System.

Applied forces and moments are strongly cabinet quantity and angle configuration dependent. Cluster configuration must be implemented and validated in NS-1 prior to installation.

Ensure that all local and National regulations regarding the safety and operation of flying equipment are understood and adhered to. Information on these regulations can usually be obtained from Local Government Offices.

When deploying a GEO M12 & MSUB18 system always wear protective headwear, footwear and eye protection.

Do not allow inexperienced persons to handle a GEO M12 & MSUB18 system. Installation personnel should be trained in loudspeaker flying techniques and should be fully conversant with this manual.

Ensure that motor hoists, hoist control systems and ancillary rigging components are currently certified as safe and that they pass a visual inspection prior to use.

Ensure that public and personnel are not allowed to pass beneath the system during the installation process. The work area should be isolated from public access.

Never leave the system unattended during the installation process.

Do not place any object, no matter how small or light, on top of the system during the installation procedure. The object may fall when the system is flown and is likely to cause injury.

Secondary safety steels must be installed once the system has been flown to the operating height. Secondary steels must be fitted irrespective of requirements of the local safety standards applicable to the territory.

Ensure that the system is secure and prevented from pivoting around the motor hoist.

Avoid any form of excessive dynamic loading to the assembly (structural computations on GEO M12 & MSUB18 Rigging System are based on a 1/1.2 factor for hoist or motor acceleration).

NEVER attach any item to the GEO M12 & MSUB18 system other than the GEO M12 & MSUB18 accessories.

When flying outdoor systems ensure that the system is not exposed to excessive wind or snow loads and is protected from rainfall.

In case of wind greater than 8 on Beaufort scale (72km/h – 45mph), a touring system has to be landed or an additional securing has to be implanted.

For fixed installations, wind loading has to be taken into account in accordance to the national standards.

The GEO M12 & MSUB18 Rigging System requires regular inspection and testing by a competent test centre. NEXO recommend that the system is load tested and certified annually or more frequently if local regulations require.

When de-rigging the system ensure that the same duty of care is given to the procedure as for the installation. Pack GEO M12 & MSUB18 components carefully to prevent damage in transit.

6.1.2 Ground Stacking Safety

Statistically, many more injuries occur due to unstable ground stacked PA systems than those associated with flown systems. There are several reasons for this fact, however the message is clear:

Always survey the supporting structure upon which a ground stack is to be built. Always look beneath PA wings to inspect the deck support and if necessary ask for the stage scrims and dressings be removed to allow access.

If the stage surface slopes, as it does in some theatres, ensure that the system is prevented from sliding forwards due to vibration. This may require the fitting of timber battens to the stage floor.

For outdoor systems ensure that that the system is protected from wind forces which might cause the ground stack to become unstable. Wind forces can be huge, especially upon large systems, and should never be underestimated. Observe meteorological forecasts, calculate the “worst case” effect upon the system prior to erection and ensure that the system is secured appropriately.

Take care when stacking cabinets. Always employ safe lifting procedures and never attempt to build stacks without sufficient personnel and equipment.

Never allow anyone, whether operators, artists or members of the public to climb onto a ground stacked PA system. Anyone who needs to climb over 2m (6 ft) high should be fitted with suitable safety equipment including a clip-on harness. Please refer to local Health and Safety legislation in your territory. Your dealer can help with advice on access to this information.

Apply the same attention to all safety matters when de-stacking systems.

Be aware that safety procedures are as important in the truck and in the warehouse as they are at the venue.

6.1.3 Contacts

Correct training is fundamental to safe practise when working with loudspeakers flying systems. NEXO recommend that users contact local industry associations for information on specialist course.

Information for International training agencies can be obtained by contacting either:

The Production Services Association
(PSA),
School Passage,
Kingston-upon-Thames,
KT1 SDU Surrey,
ENGLAND
Telephone: +44 (0) 181 392 0180
www.psa.org.uk/

Rigstar Training and Testing Center
82 Industrial Dr. Unit 4
Northampton, Massachusetts
01060 U.S.A.
Phone: 413-585-9869
www.rigstar.com/

ESTA
Entertainment Services & Technology
Association
875 Sixth Avenue, Suite 1005
NEW YORK, NY 10001 USA
Phone: 212-244-1505
www.esta.org

6.2 General Description

6.2.1 GEO M1210 and GEO M1220

IMPORTANT

GEO M1210 & GEO M1220 share the same geometry and fittings, but different wavefront curvatures. In order to distinguish one from the other,

GEO M1210 is marked with the following sign on its sides:

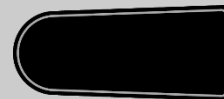

GEO M1220 is marked with the following sign on its sides:



6.2.2 GEO M12 “Left” and “Right” configuration

GEO M12 can be installed “Left” or “Right”:

- “Left” means HF waveguide is left as seen from front
- “Right” means HF waveguide is right as seen from front

GEO M12 can be connected to bumpers “Left” or “Right” by simply flipping the cabinets. Whenever possible, NEXO recommends symmetrical designs (preferably HF waveguide inwards in stereo configurations)

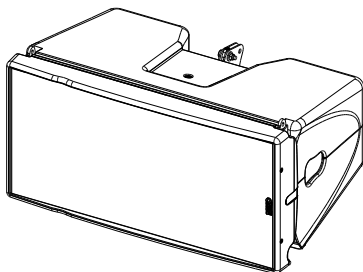

GEO M12 “Left”

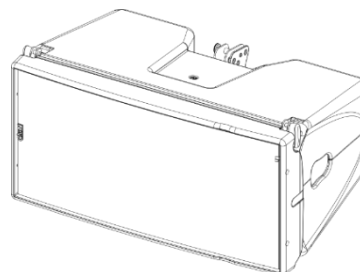

GEO M12 “Right”

6.2.3 GEO M12 and MSUB18 rigging systems

GEO M12 features a 3-points rigging system, 2 for front connection, and 1 for rear connection and angle splay settings.

- Front connection of two subsequent modules is ensured by an AutoRig™ system, with 3 positions: open / ready to lock / locked (only on touring version).

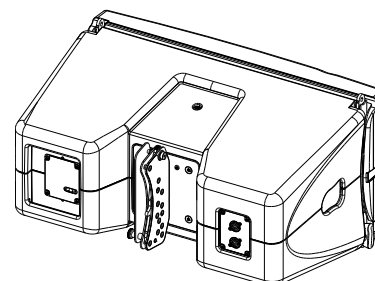

- Rear connection of two subsequent modules is ensured by a link bar, with one safety point on a latch and one quick release pin to adjust angle settings.

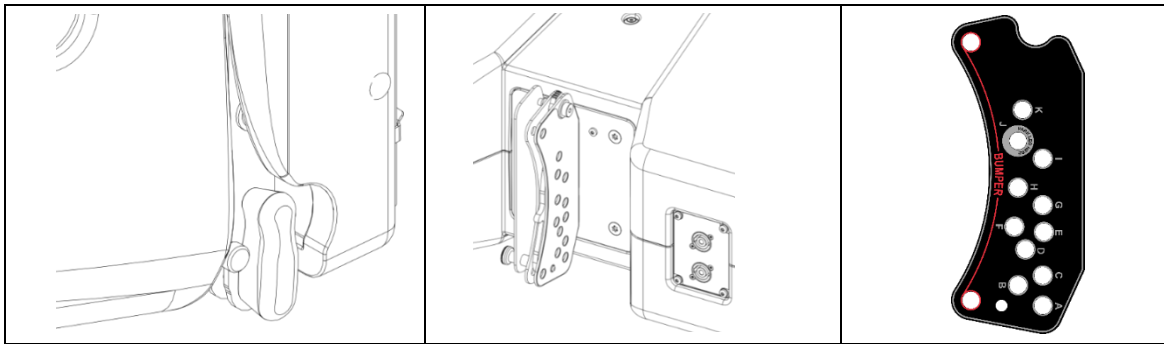

GEO M12 front rigging points

GEO M12 rear rigging points

GEO M12 angle settings

Angle splay setting sequences are as follow:

- GEO M1210 to GEO M1210: 0.25° (A) / 0.5° (B) / 1° (C) / 2° (D) / 3.5° (E) / 5° (F) / 7° (G) / 10° (H)
- GEO M1210 to GEO M1220: 10° (H) / 13° (I)
- GEO M1220 to GEO M1220: 13° (I) / 16° (J) / 20° (K)

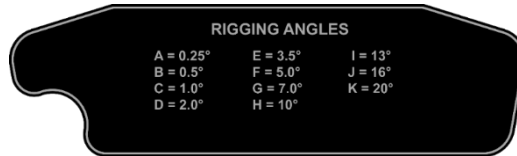

MSUB18 features a 4-points rigging system:

- Upper connection features retractable rigging links that can be unlocked from the sides
- Lower connection features semi-auto lock rigging points that lock with latches on the sides

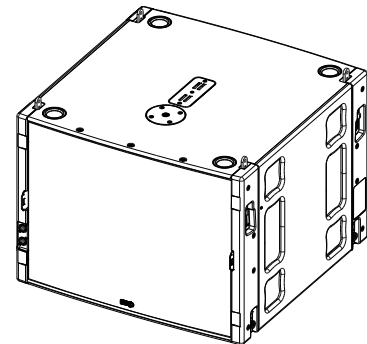

Front and rear rigging points are identical so that MSUB15 count be mounted reverse for cardioid setups

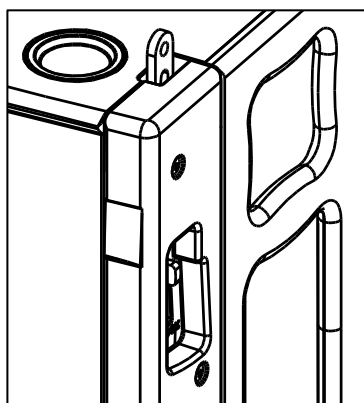

MSUB18 upper rigging points

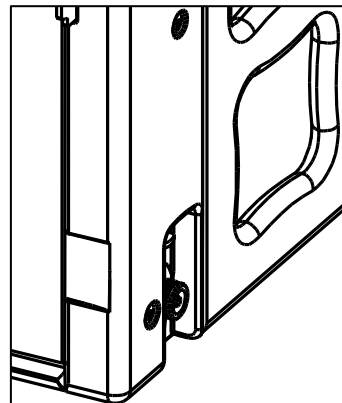

MSUB18 lower rigging points

Angle splay setting sequences are as follow:

- MSUB18 to MSUB18: 0°
- MSUB18 to GEO M1210 (or M1220): -12° / -9° / -6° / -3° / 0° / +3° / +6° / +9° / +12°

6.2.4 GEO M12-I and MSUB18-I rigging systems

For permanent installations where systems won't have to be frequently assembled and disassembled

- GEO M12 AutoRig™ is replaced by an axis with break nuts
- GEO M12 rear pin is replaced by a shoulder screw with a break nut
- MUB18 semi auto-lock system is replaced with pins and safety clips

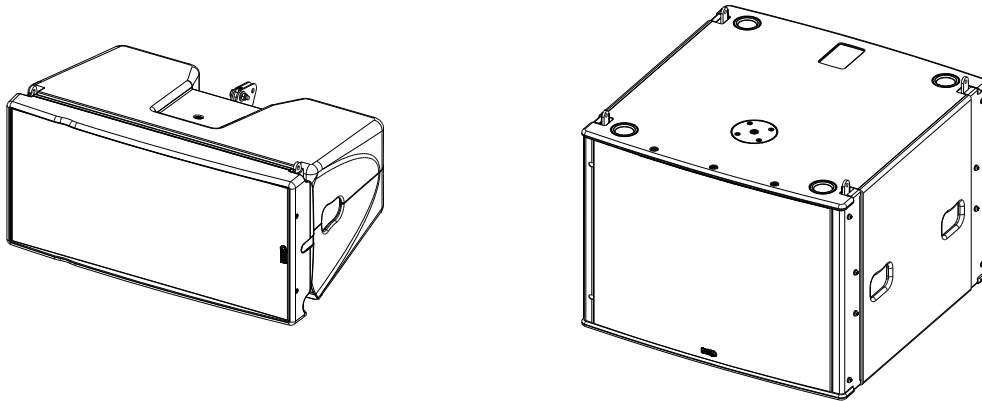

Please note that these are shipped together with GEO M12-I and MSUB18-I



6.2.5 Accessories

GEO M12 & MSUB18 accessories are:

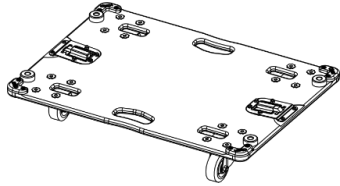
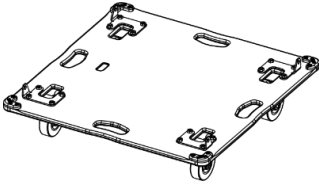
<p>VNT-BUMPM12</p>	<p>VNT-EXBARM12</p>	<p>VNI-BUMPM12</p>
<p>VNT-GSTKM10M12L</p>	<p>VNT-GSTKM10M12S</p>	<p>VNT-MNSTKM12</p>
<p>GMT-LBUMPM12</p>	<p>GMT-EXBARM12L</p>	<p>GMT-FLGM12</p>

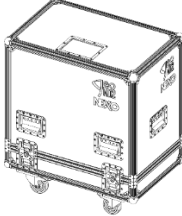
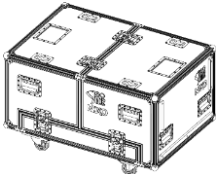
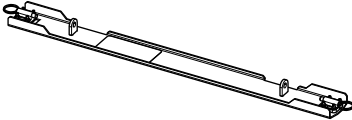
<p>MST-WBMSUB18</p> 	<p>MST-DOLLYMSUB18</p> 	<p>MST-COVMSUB18</p> 
<p>MST-COV2MSUB18</p> 	<p>GMT-2CASEM12</p> 	<p>GMT-3CASEM12</p> 
<p>VNT-LSTKM1018</p> 		

6.2.6 Warnings on GEO M12 & MSUB18 accessories

WARNING

All GEO M12 Accessories are specifically rated in agreement with structural computations. Never use other accessories – including push-pins - when assembling GEO M12 cabinets than the ones provided by NEXO: NEXO will decline responsibility over the entire GEO M12 accessory range if any component is purchased from different supplier.

WARNING

All GEO M12 accessories have been designed so that cabinets are arrayed vertically. GEO M12 horizontal assemblies as shown in figure below are UNSAFE and STRICTLY PROHIBITED.

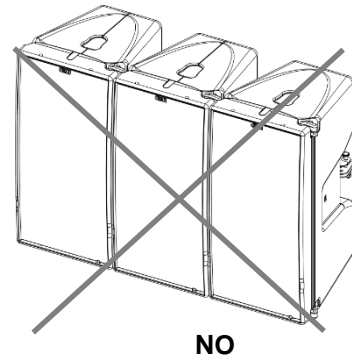
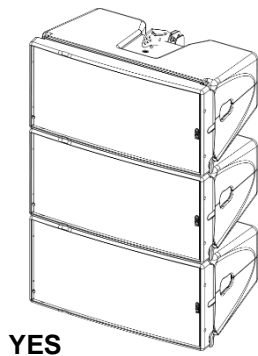

6.3 Ground Stack setups

6.3.1 Described configurations

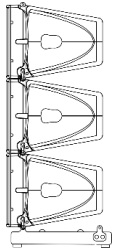
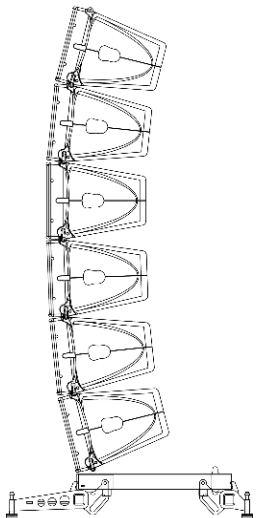
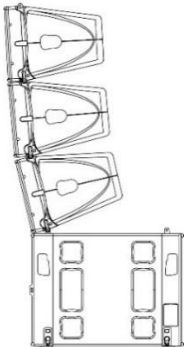
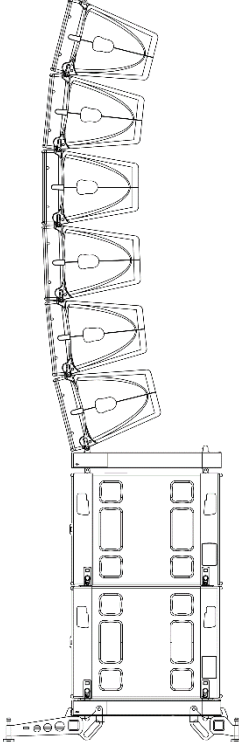
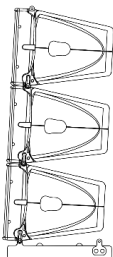
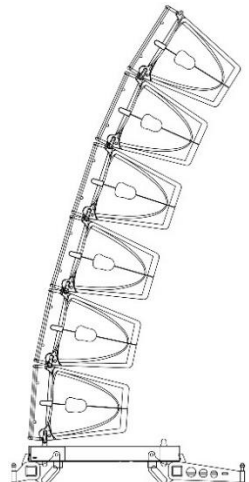
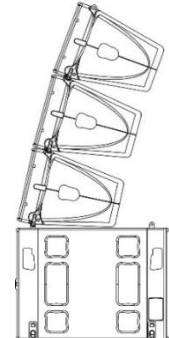
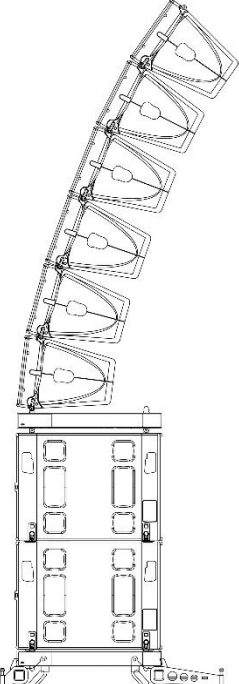
GEO M12 only Light Bumper	GEO M12 only Touring Bumper + Extensions	MSUB18 + GEO M12 Ministack	MSUB18 + GEO M12 Touring Bumper + Extensions
			
			

6.3.2 GEO M12 only on Lightweight Bumper

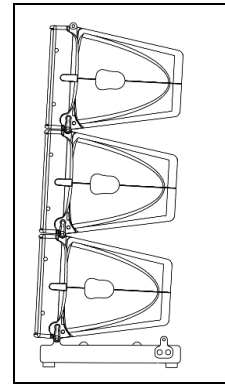
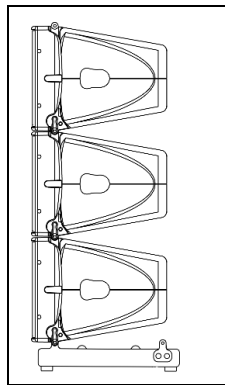

Required item

- 1 x GMT-LBUMPM12

IMPORTANT

GMT-LBUMPM12 is rated for a maximum of 3 stacked GEO M12 in any inter cabinet angle configuration with 0/+3° initial angle, provided the stack is assembled according to below rules:

- GMT-LBUMPM12 must always be installed on a horizontal surface
- Public is not allowed within a safety area which radius is equal or higher than assembly height.

Procedure

GMT-LBUMPM12 can be flipped front and back depending if it connects to GEO M12 Right or Left.

- When connecting GEO M12 Left, bumper front is on the “G” hole index side
- When connection GEO M12 Right, bumper front is on the “A” hole index side

GEO M12 Left

- Set the bumper on the ground so that front is on the “G” hole side
- Remove the BL825 quick release pin of rear GMT-LBUMPM12 link bar, and rotate it upwards
- Release first GEO M12 link bar, and set AutoRig in automatic lock position
- Position first GEO M12 on top of the bumper, front points will lock automatically
- Connect the bumper link bar (selection of 0° / +3°) to GEO M12 rear rigging plate (hole marked “bumper”) Lock with the quick release pin BL0825.

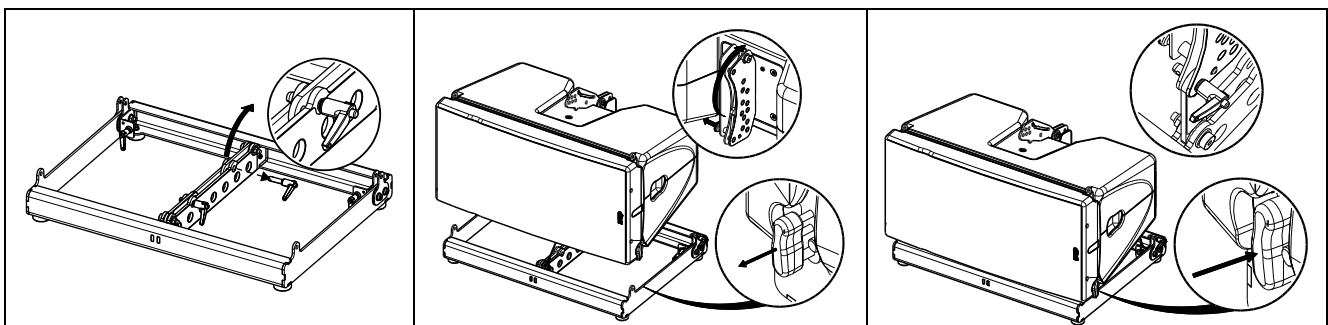

IMPORTANT

Ensure that all AutoRig™ systems are locked

GEO M12 Right

- Set the bumper on the ground so that front is on the “A” hole side
- Remove the two BL820 quick release pins from their side storage position, and the BL825 quick release pin of rear GMT-LBUMPM12 link bar.
- Release GEO M12 link bar.
- Position first GEO M12 on top of the bumper and lock it to the bumper with the 2 BL820 quick release pins.
- Connect the bumper link bar (selection of 0° / +3°) to GEO M12 rear rigging plate (hole marked “bumper”) Lock with the quick release pin BL0825.

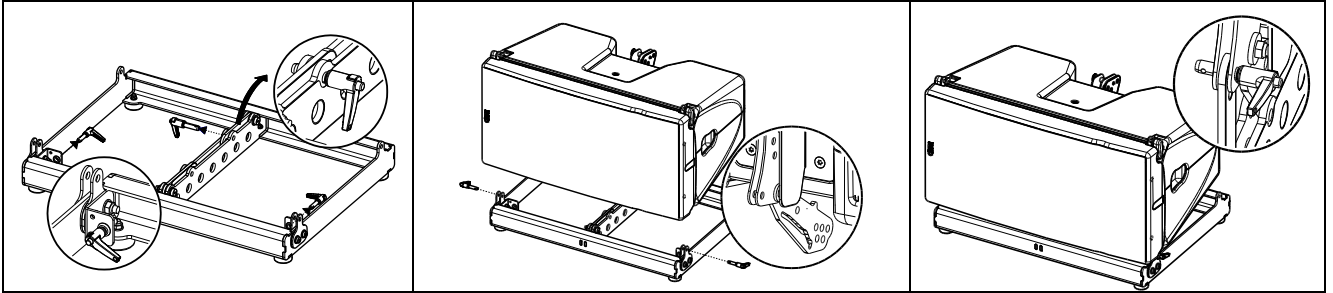
Subsequent GEO M12s

- Position second GEO M12 cabinet with AutoRig™ in automatic lock position, and lock front points to first GEO M12
- Unlock GEO M12 link bar
- Pull the latch to engage the guide in GEO M12 rear slot.
- Adjust the angle by inserting quick release pin BL820 in proper hole.
- Connect subsequent GEO M12 cabinets as with second.

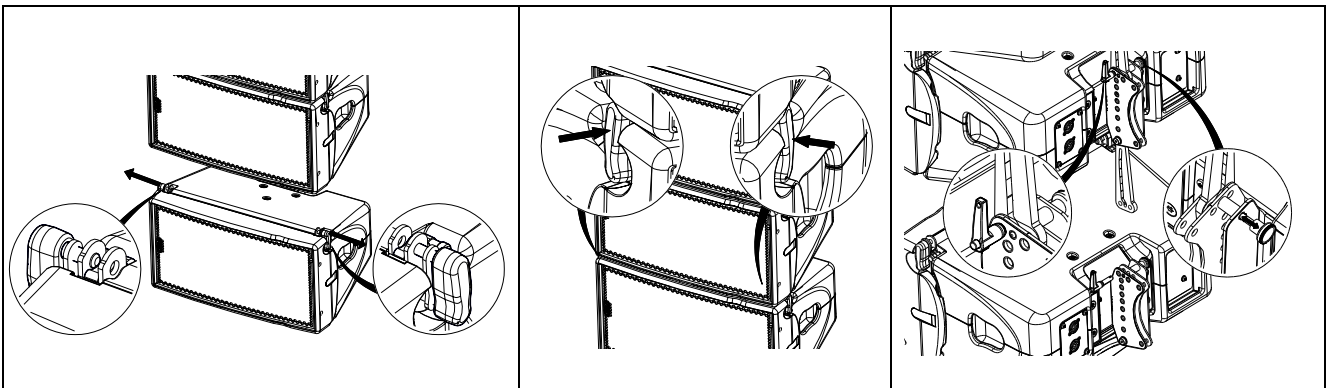
**IMPORTANT**

Ensure that bumper quick release pins are properly locked into GEO M12, and that all AutoRig™ and rear pins are locked

Disassembly

- On both side, pull AutoRig™ and hold the side knob (AutoRig™ remains in the open position).
- Remove the rear quick release pin BL820
- Unlock the GEO M12 link bar by pulling the latch.
- Disassemble GEO M12s

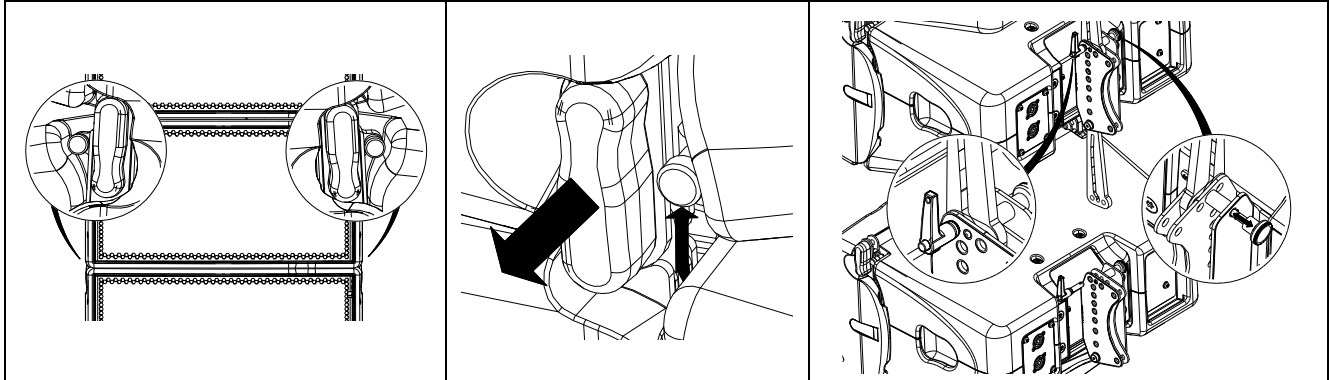

6.3.3 GEO M12 only on Touring Bumper with stacking extensions

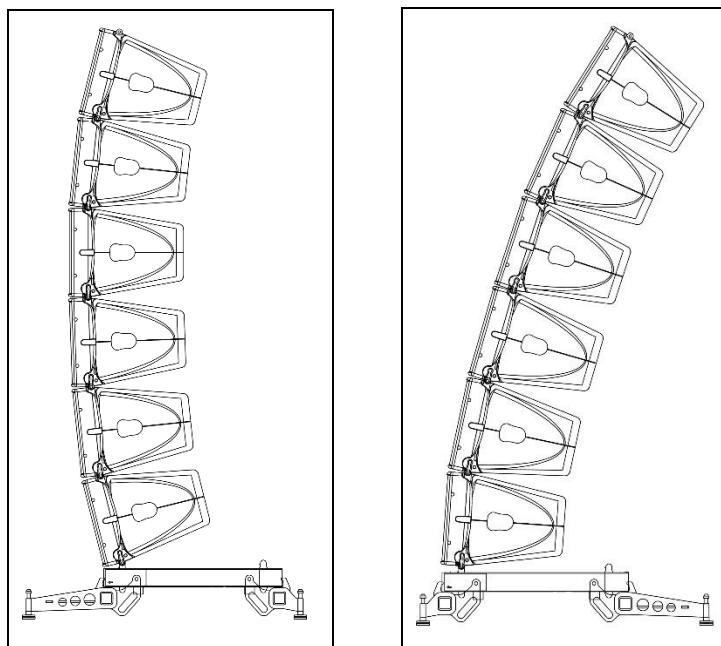

Required item

- 1 x VNT-BUMPM12
- 1 x VNT-GSTKM10M12S
- 1 x VNT-GSTKM10M12L

IMPORTANT

Ground stack assembly VNT-BUMPM12 + VNT-GSTKM10M12S + VNT-GSTKM10M12L is rated for a maximum of 6 x GEO M12 in any inter cabinet angle configuration with $\pm 12^\circ$ initial angle, provided this device is assembled according to below rules:

- VNT-BUMPM12 must be adjusted to be horizontal
- Public is not allowed within a safety area which radius is equal or higher than assembly height.
- It is highly recommended to secure the system to a fix point located at the back of the stack.

Procedure

- Set the bumper on the ground so that front with front direction indicated by side arrows
- Insert VNT-GSTKM10M12L and/or VNT-GSTKM10M12S guides into bumper front and rear center slots

IMPORTANT

If bottom GEO M102 angle is negative, VNT-GSTKM10M12L must be connected at the front and VNT-GSTKM10M12S at the back

If bottom GEO M12 angle is positive, VNT-GSTKM10M12S must be connected at the front and VNT-GSTKM10M12L at the back

- Lock VNT-GSTKM10M12L and/or VNT-GSTKM10M12S into bumper with VNT-BUMPM12 quick release pin 1240.

- Adjust feet height so that bumper is horizontal

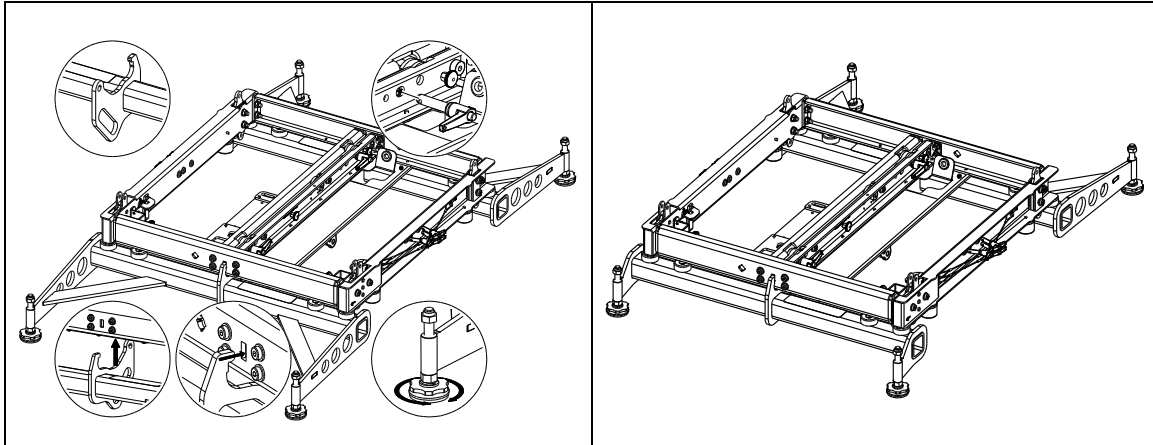

- Pull latch to release the VNT-BUMPM12 center link bar, and rotate it upwards
- Pull the bumper front latches, rotate the upper link so that connection points are single leg (GEO M12 Left) or double leg (GEO M12 Right) and release the latches to lock in required position

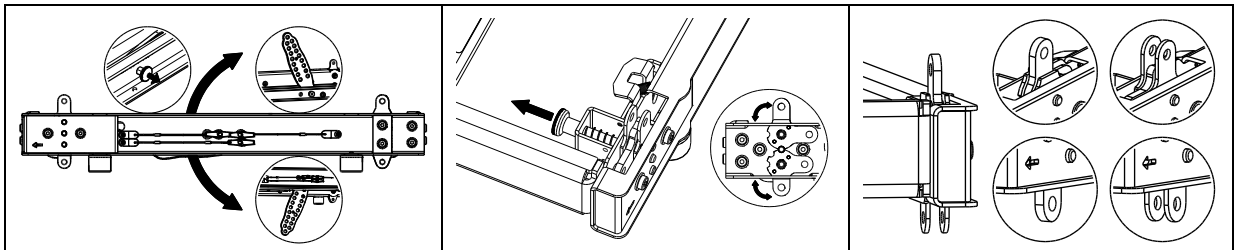

GEO M12 Left

- Release first GEO M12 link bar, and set AutoRig in automatic lock position
- Position first GEO M12 on top of the bumper, front points will lock automatically
- Connect the bumper link bar (selection from -12° to $+12^\circ$ in 3° steps) to GEO M12 rear rigging plate (hole marked "bumper") Lock with the quick release pin BL0820.

GEO M12 Right

- Release first GEO M12 link bar.
- Position first GEO M12 on top of the bumper and lock it to the bumper with the 2 BL820 quick release pins.
- Connect the bumper link bar (selection from -12° to $+12^\circ$ in 3° steps) to GEO M12 rear rigging plate (hole marked "bumper") Lock with the quick release pin BL0825.

Subsequent GEO M12s

- Position second GEO M12 cabinet with AutoRig™ in automatic lock position, and lock front points to first GEO M12
- Unlock GEO M12 link bar
- Pull the latch to engage the guide in GEO M12 rear slot.
- Adjust the angle by inserting quick release pin BL820 in proper hole.

- Connect subsequent GEO M12 cabinets as with second.

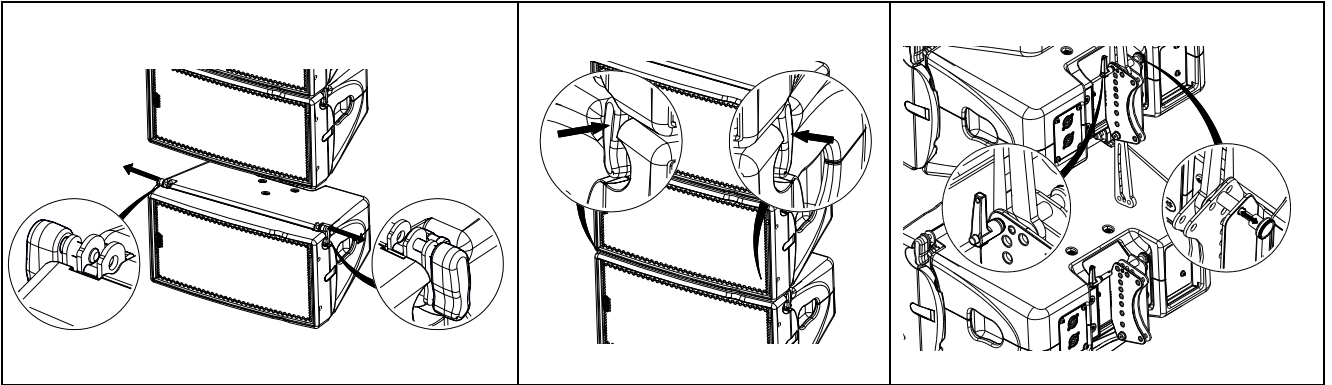

IMPORTANT

Ensure that bumper quick release pins are properly locked into GEO M12, and that all AutoRig™ and rear pins are locked

Disassembly

- On both side, pull AutoRig™ and hold the side knob (AutoRig™ remains in the open position).
- Remove the rear quick release pin BL820
- Unlock the GEO M12 link bar by pulling the latch.
- Disassemble GEO M12s

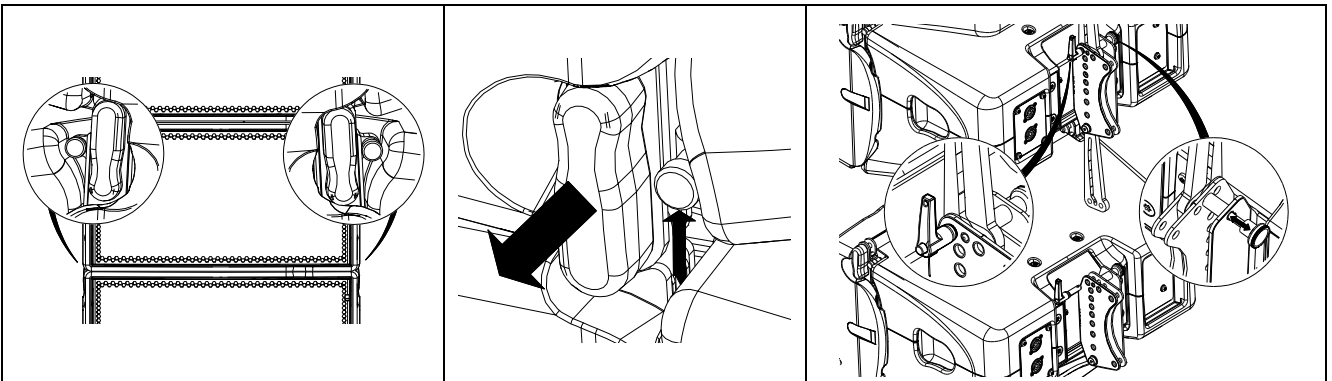

6.3.4 MSUB18 and GEO M12 with Ministack adaptor

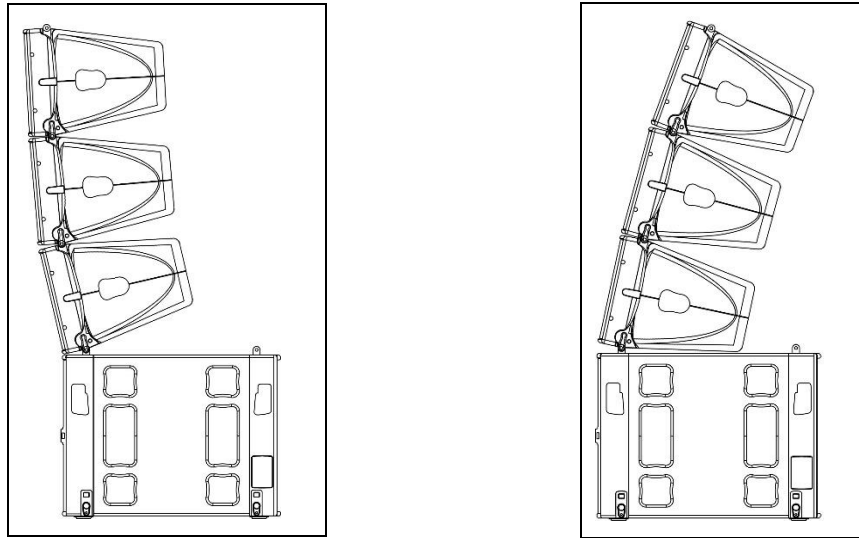

Ministack adaptor only allows to stack GEO M12 in "left" configuration

Required item

- 1 x VNT-MNSTKM12

IMPORTANT

Ground stack assembly is rated for a maximum of 2 x MSUB18 + 3 x GEO M12 in any inter cabinet angle configuration with +12/-15° initial angle, provided this device is assembled according to below rules:

- MSUB18 must always be installed on a horizontal surface
- Public is not allowed within a safety area which radius is equal or higher than assembly height.

Procedure

- Position first MSUB18 on the ground
- Position second MSUB18 (front or back) on top of first, and lock front and rear connecting points
- Pull the latch to unlock the link bar of VNT-MNSTKM12
- Insert VNT-MNSTKM12 back into MSUB18 rear upper slot and push it forward so that front opening are aligned with MSUB18 front connecting points.
- Unlock upper MSUB18 connecting points

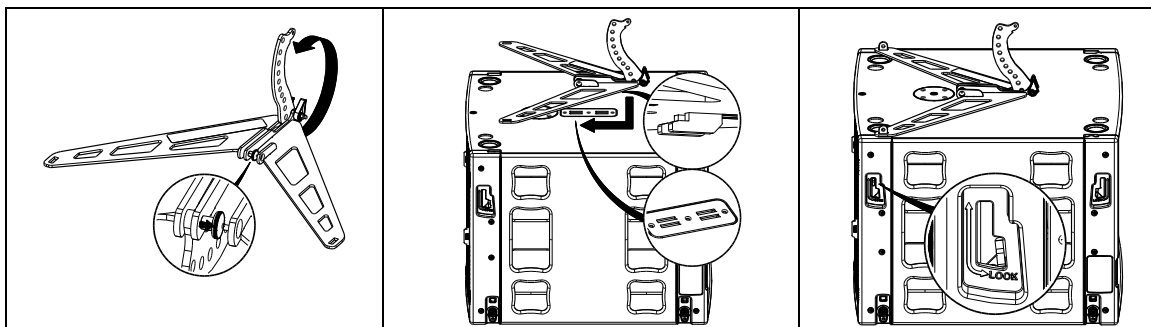

- Use the levers to lock VNT-MNSTKM12 on MSUB18

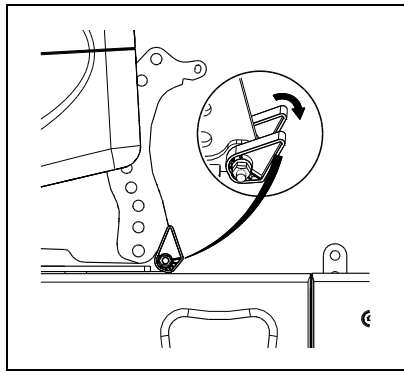

- Release first GEO M12 link bar, and set AutoRig in automatic lock position
- Position first GEO M12 on top of the VNT-MNSTKM12, front points will lock automatically
- Connect the VNT-MNSTKM12 link bar (selection from -15° to +12° in 3° steps) to GEO M12 rear rigging plate (hole marked “bumper”) Lock with the quick release pin BL0820.

		<p>Y ⇨ - 15°</p> <p>Z ⇨ - 12°</p> <p>X ⇨ - 9°</p> <p>V ⇨ - 6°</p> <p>T ⇨ - 3°</p> <p>S ⇨ 0°</p> <p>R ⇨ + 3°</p> <p>Q ⇨ + 6°</p> <p>P ⇨ + 9°</p> <p>N ⇨ + 12°</p>
--	--	--

Subsequent GEO M12s

- Position second GEO M12 cabinet with AutoRig™ in automatic lock position, and lock front points to first GEO M12
- Unlock GEO M12 link bar
- Pull the latch to engage the guide in GEO M12 rear slot.
- Adjust the angle by inserting quick release pin BL820 in proper hole.
- Connect subsequent GEO M12 cabinets as with second.

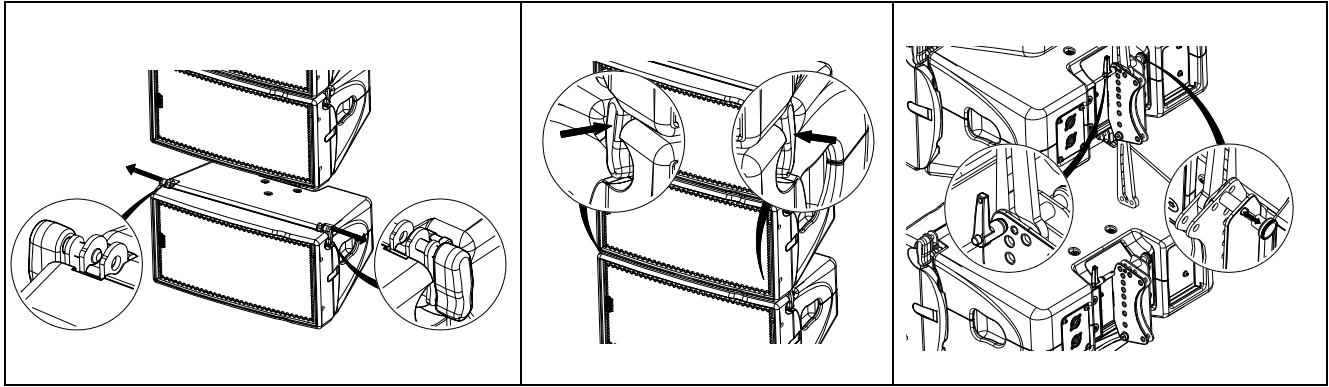

IMPORTANT

Ensure that bumper quick release pins are properly locked into GEO M12, and that all AutoRig™ and rear pins are locked

Disassembly

- On both side, pull AutoRig™ and hold the side knob (AutoRig™ remains in the open position).
- Remove the rear quick release pin BL820
- Unlock the GEO M12 link bar by pulling the latch.
- Disassemble GEO M12s

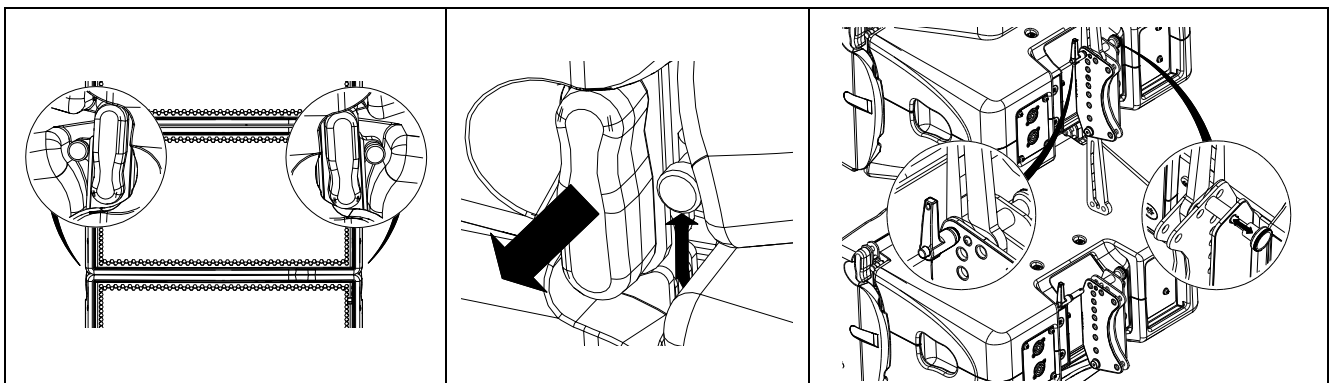

6.3.5 MSUB18 and GEO M12 on Touring Bumper with stacking extensions

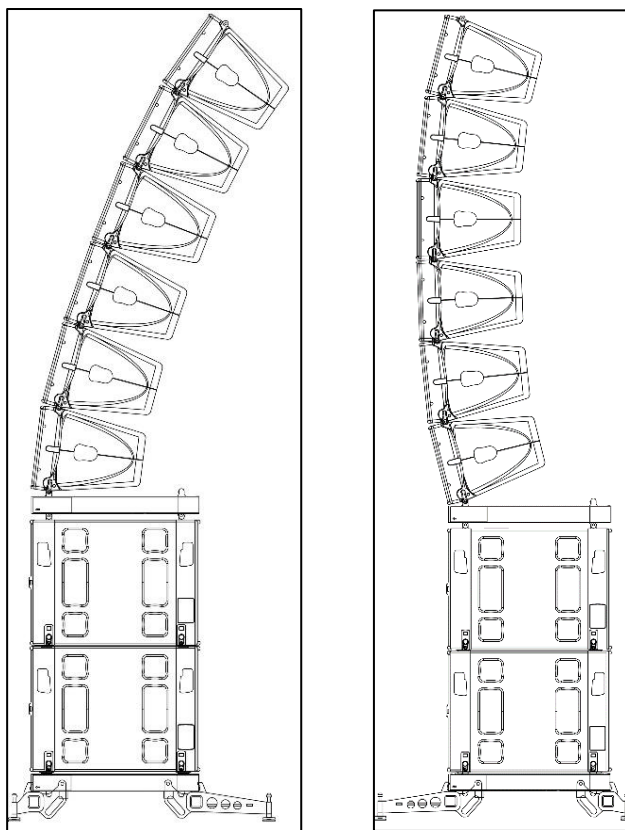

Required item

- 2 x VNT-BUMPM12
- 1 x VNT-GSTKM10M12S
- 1 x VNT-GSTKM10M12L

IMPORTANT

Ground stack assembly VNT-BUMPM12 + VNT-GSTKM10M12S + VNT-GSTKM10M12L is rated for a maximum of 2 x MSUB18 + 6 x GEO M12 in any inter cabinet angle configuration with $\pm 12^\circ$ initial angle, provided this device is assembled according to below rules:

- VNT-BUMPM12 must be adjusted to be horizontal
- Public is not allowed within a safety area which radius is equal or higher than assembly height.
- It is highly recommended to secure the system to a fix point located at the back of the stack.

Procedure

- Set the bumper on the ground so that front with front direction indicated by side arrows
- Insert VNT-GSTKM10M12L and/or VNT-GSTKM10M12S guides into bumper front and rear center slots

IMPORTANT

- If bottom GEO M12 initial angle is negative, VNT-GSTKM10M12L must be connected at the front and VNT-GSTKM10M12S at the back
- If bottom GEO M12 initial angle is positive, VNT-GSTKM10M12S must be connected at the front and VNT-GSTKM10M12L at the back

- Lock VNT-GSTKM10M12L and/or VNT-GSTKM10M12S into bumper with VNT-BUMPM12 quick release pin 1240.
- Adjust feet height so that bumper is horizontal

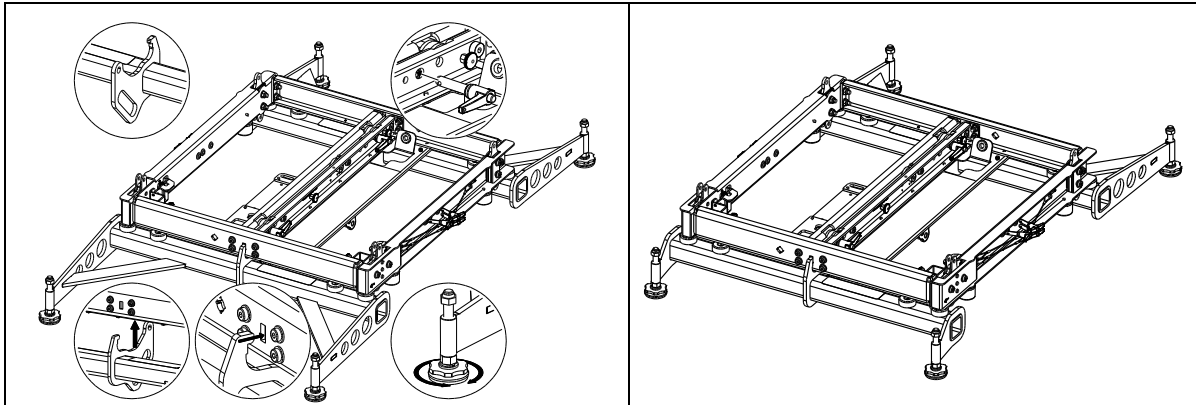

- Pull the bumper front latches, rotate the upper links so that connection points are single leg and release the latches.

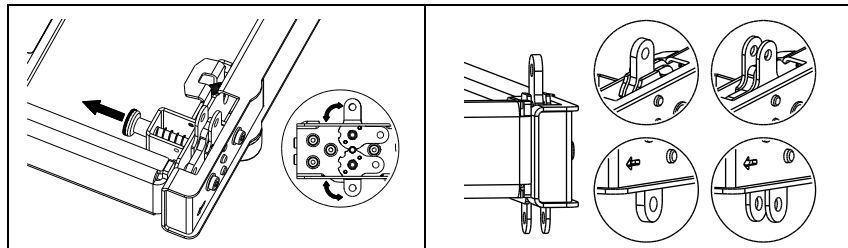

- Align first MSUB18 on top of VNT-BUMPM12, and lock them by releasing front and rear MSUB18 bottom latches connecting points
- Unlock the 4 MSUB18 upper connecting points
- Align second MSUB18 on top of first, and lock them by releasing front and rear upper MSUB18 latches connecting points

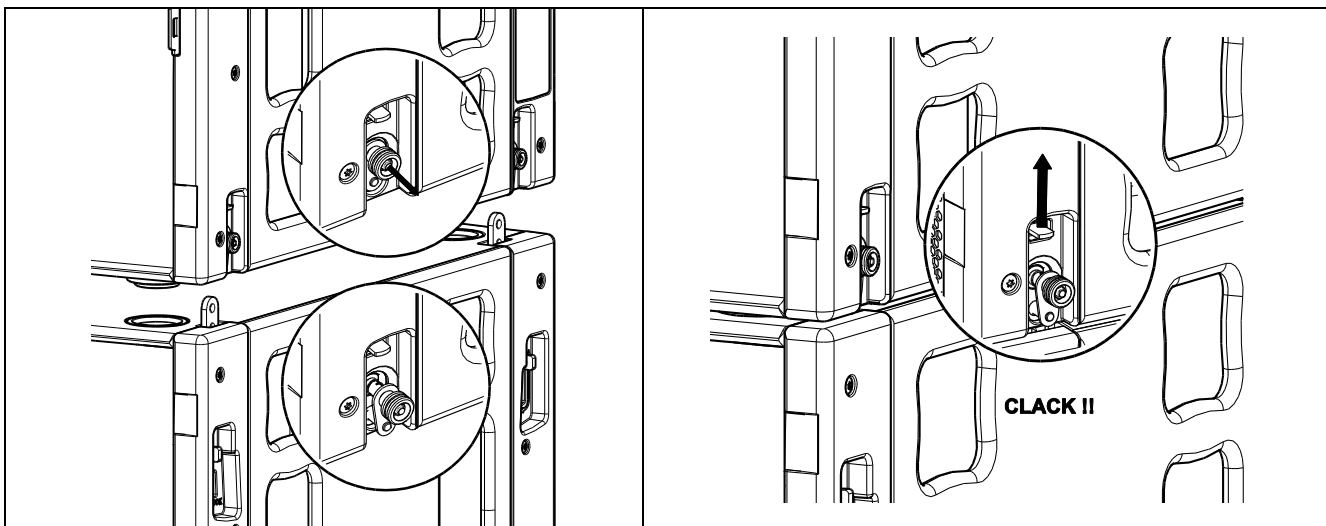

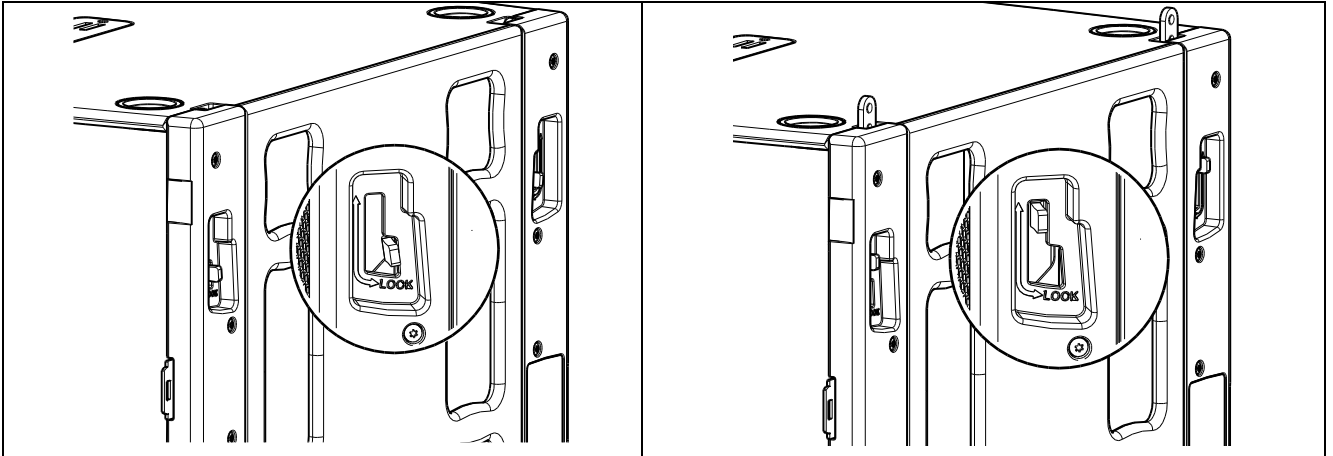

- Position second VNT-BUMPM12 on top of MSUB18
- Pull the bumper front latches, rotate the lower links so that connection points are double leg and release the latches.

GEO M12 Left

- Pull the bumper front latches, rotate the upper links so that connection points are single leg and release the latches.
- Release first GEO M12 link bar, and set AutoRig™ in automatic lock position
- Position first GEO M12 on top of the bumper, front points will lock automatically
- Connect the bumper link bar (selection from -12° to +12° in 3° steps) to GEO M12 rear rigging plate (hole marked "bumper") Lock with the quick release pin BL0820.

GEO M12 Right

- Pull the bumper front latches, rotate the upper links so that connection points are double leg and release the latches.
- Release first GEO M12 link bar.
- Position first GEO M12 on top of the bumper and lock it to the bumper with the 2 BL820 quick release pins.
- Connect the bumper link bar (selection from -12° to +12° in 3° steps) to GEO M12 rear rigging plate (hole marked "bumper") Lock with the quick release pin BL0825.

Subsequent GEO M12s

- Position second GEO M12 cabinet with AutoRig™ in automatic lock position, and lock front points to first GEO M12
- Unlock GEO M12 link bar
- Pull the latch to engage the guide in GEO M12 rear slot.
- Adjust the angle by inserting quick release pin BL820 in proper hole.
- Connect subsequent GEO M12 cabinets as with second.

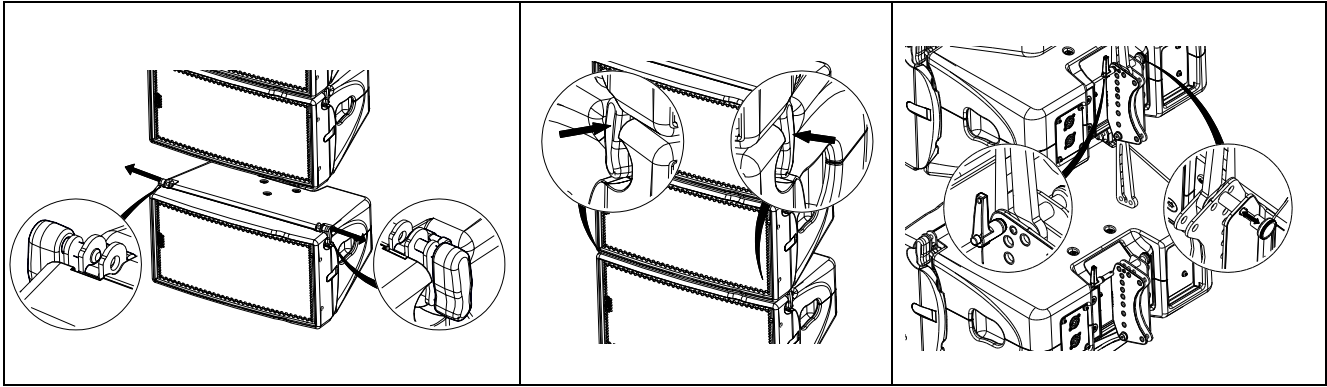
**IMPORTANT**

Ensure that bumper quick release pins are properly locked into GEO M12, and that all AutoRig™ and rear pins are locked

Disassembly

- On both side, pull AutoRig™ and hold the side knob (AutoRig™ remains in the open position).
- Remove the rear quick release pin BL820
- Unlock the GEO M12 link bar by pulling the latch.
- Disassemble GEO M12s

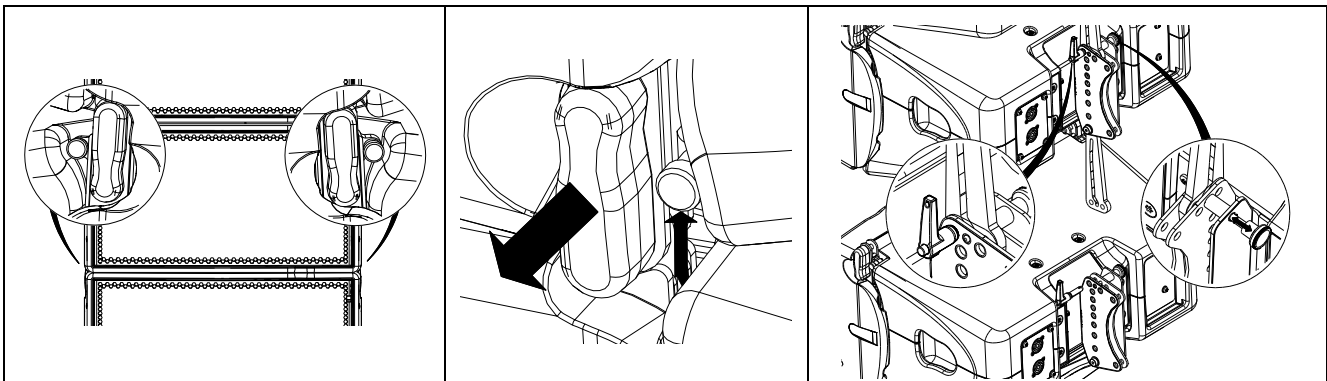

6.4 Flown clusters setups

6.4.1 Described configurations

	GEO M12 only Light Bumper	GEO M12 only Touring Bumper	MSUB18 only Touring Bumper	MSUB18 + GEO M12 Touring Bumper
1 rigging point				
2 rigging points				

6.4.2 GEO M12 only flown with Lightweight Bumper

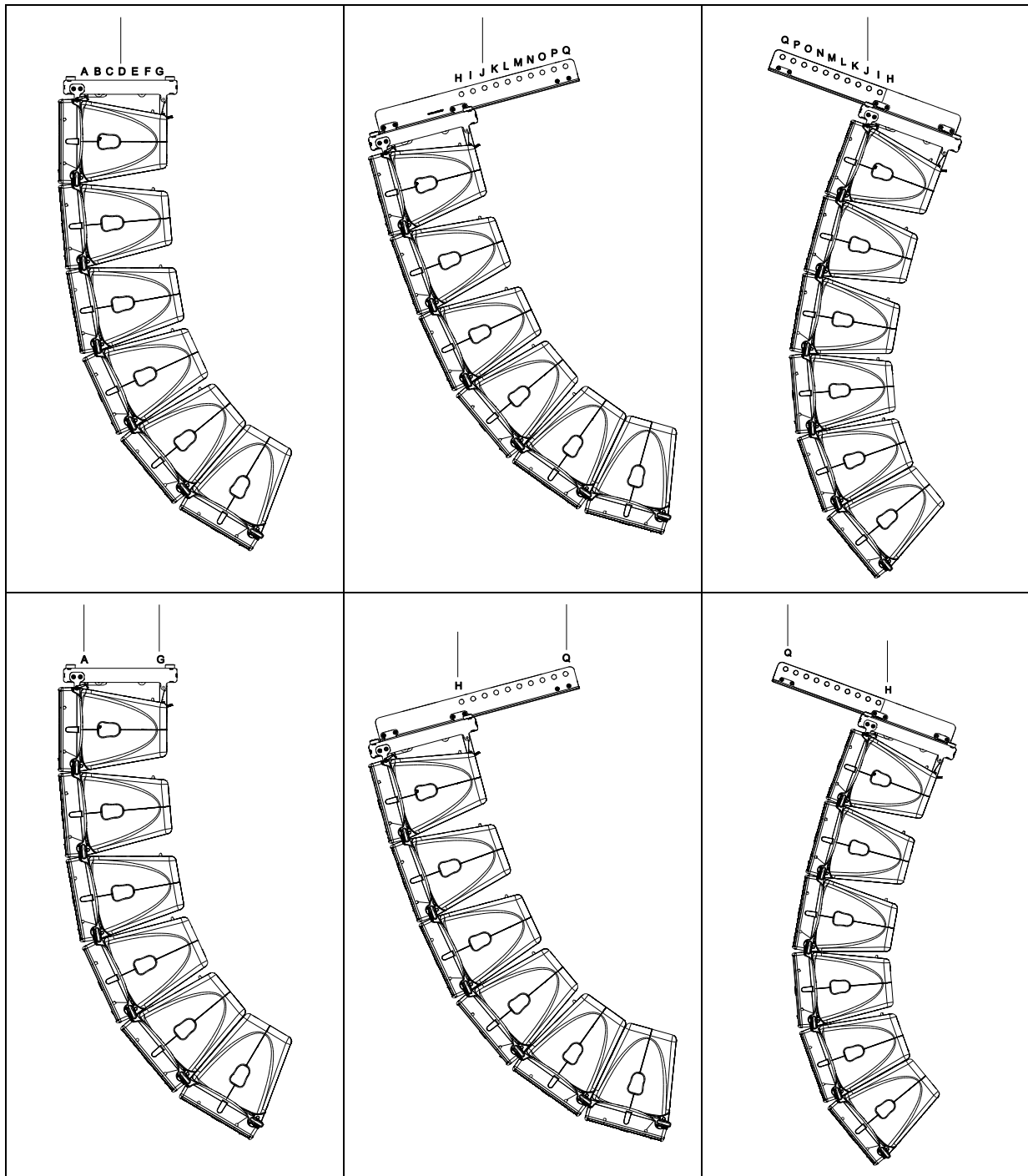

Required items

- 1 or 2 hoists (not provided).
- 1 x GMT-LBUMPM12
- 1 x GMT-EXBARM12L for extended positive and negative bumper angles

IMPORTANT

Maximum GEO M12 quantity for flown vertical cluster with GMT-LBUMPM12 is 12 (and eventually less).

Please check NS-1 for mechanical Safety Working Load and acoustic computations.

IMPORTANT

Motor hoist must be rated to support entire cluster weight. Please check configuration in NS-1 for proper motor hoist rating

Procedure

GMT-LBUMPM12 can be flipped front and back depending if its connects to GEO M12 Right or Left.

- When connecting GEO M12 Left, bumper front is on the “A” hole index side
- When connection GEO M12 Right, bumper front is on the “G” hole index side

GEO M12 Left

- Position first GEO M12 so that Autorig™ is at the bottom
- Position bumper (“A” hole at front) on top of first GEO M12
- Remove the two BL820 quick release pins from their side storage position, and the BL825 quick release pin of rear bumper link bar.
- Connect bumper front points to GEO M12 with the BL820 quick release pins
- Connect the bumper link bar (0° position) to GEO M12 rear rigging plate (hole marked “bumper”) Lock with the quick release pin BL0825.

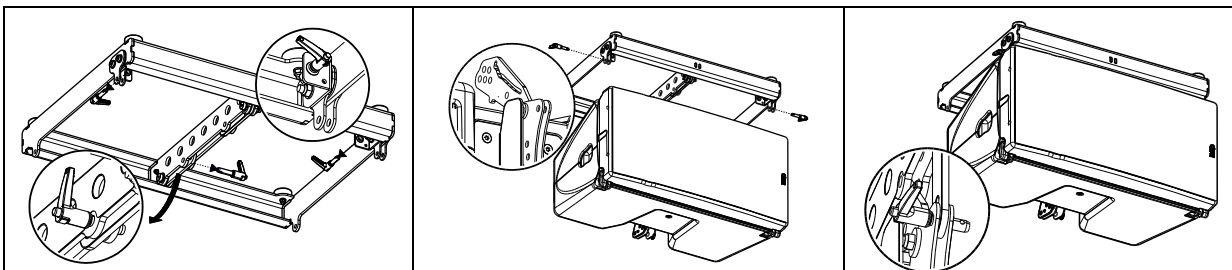
GEO M12 Right

- Position GEO M12 so that Autorig™ is at the top and set in automatic lock position
- Position bumper (“G” hole at front) on top of first GEO M12
- Remove the the BL825 quick release pin of rear bumper link bar.
- Connect bumper front points to GEO M12, front points will lock automatically
- Connect the bumper link bar (0° position) to GEO M12 rear rigging plate (hole marked “bumper”) Lock with the quick release pin BL0825.

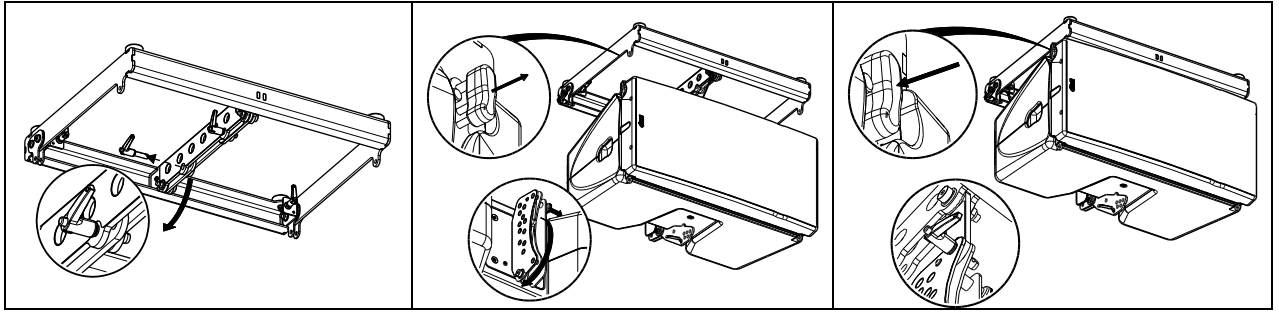

- If required, connect GMT-EXBARM12L to GMT-LBUMPM12 by inserting GMT-EXBARM12L clevis pins into GMT-LBUMPM12 "B" and "F" holes

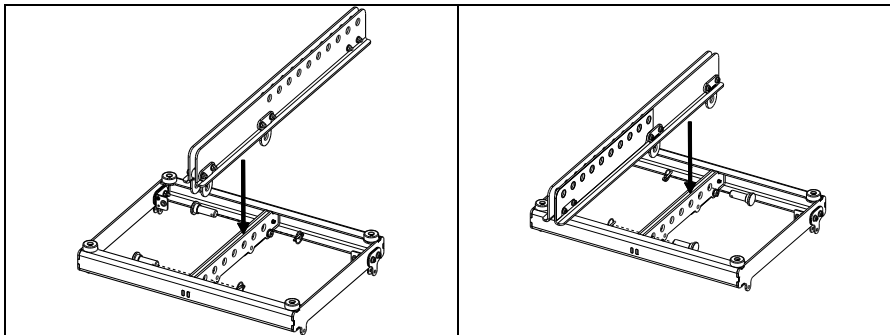

- Insert shackle(s) in bumper or in extension in required hole(s) as indicated in NS1 design and secure shackle bolt(s);
 - o "A" to "G" on GMT-LBUMPM12
 - o Or "H" to "Q" if using GMT-EXBARM12L
 - o If using 2 hoists, connect these using extreme points ("A" and "G", or "H" and "Q")
- Connect hoist hook(s) to shackle(s) and lift assembly to sufficient height in order to connect a second GEO M12

IMPORTANT

**Ensure hoist hook(s) is (are) properly secured to GMT-LBUMPM12 or GMT-EXBARM12L
Ensure that all quick release pins are locked**

Subsequent GEO M12s

- Position second GEO M12 cabinet with AutoRig™ in automatic lock position, and lock front points to first GEO M12
- Unlock GEO M12 link bar
- Pull the latch to engage the guide in GEO M12 rear slot.
- Adjust the angle by inserting quick release pin BL820 in proper hole.
- Connect subsequent GEO M12 cabinets as with second.

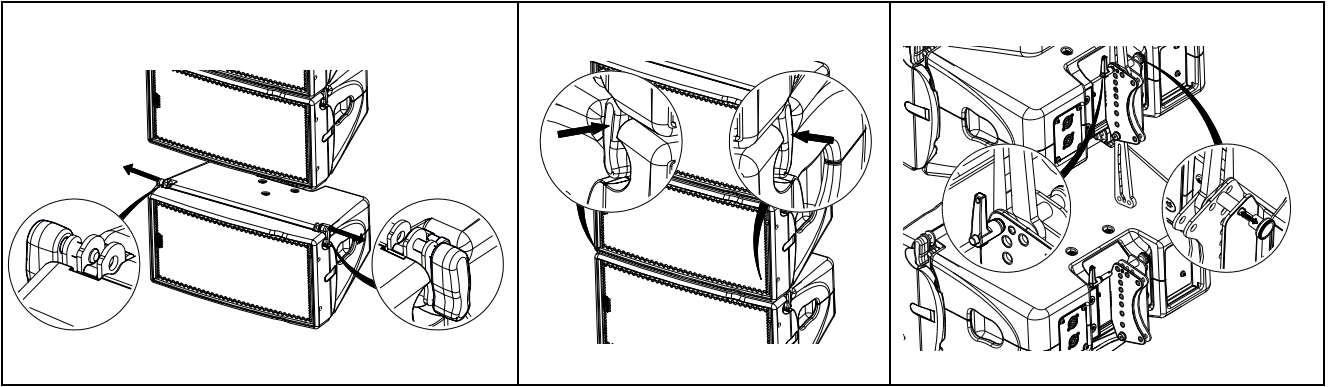

IMPORTANT

Ensure that bumper quick release pins are properly locked into GEO M12, and that all AutoRig™ and rear pins are locked

- Lift cluster to NS-1 defined rigging height, secure cluster horizontally to prevent it from rotating;
- Secure bumper with secondary safety steel.

IMPORTANT

The requirements for secondary safety systems vary with territories. However, the secondary safety steel **MUST** have a SWL equivalent or greater than that of the rigging system.

Disassembly

- While holding GEO M12 to be dismantled, pull AutoRig™ on both sides and hold the side knob (AutoRig™ remains in the open position).
- Remove the rear quick release pin BL820
- Unlock the GEO M12 link bar by pulling the latch.
- Remove GEO M12

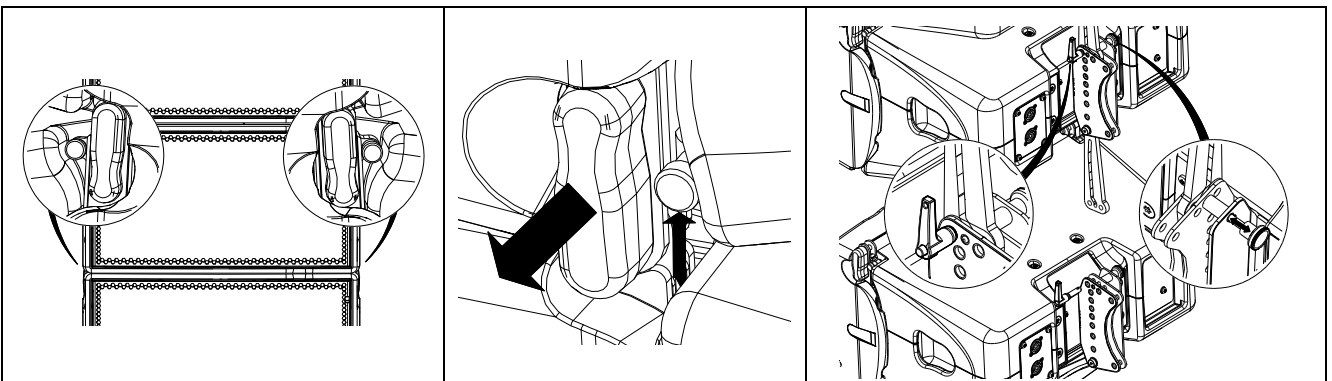

6.4.3 GEO M12 flown with Touring Bumper

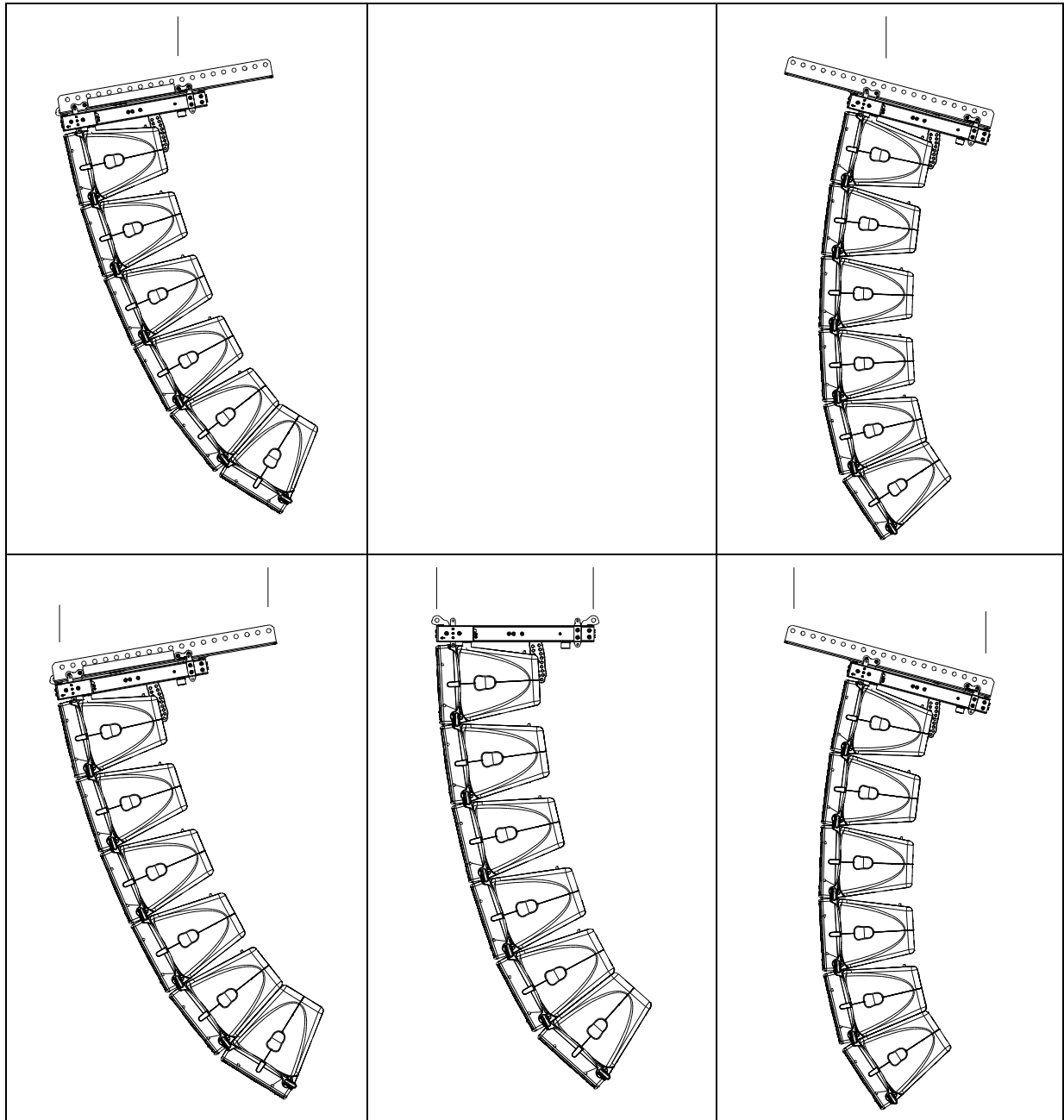

Required items

- 1 or 2 hoists (not provided).
- 1 x VNT-BUMPM12
- 1 x VNT-EXBARM12 for extended positive and negative bumper angles

IMPORTANT

Maximum GEO M12 quantity for flown vertical cluster with VNT-BUMPM12 is 12 (and eventually less).

Please check NS-1 for mechanical Safety Working Load and acoustic computations.

IMPORTANT

Motor hoist must be rated to support entire cluster weight. Please check configuration in NS-1 for proper motor hoist rating

ProcedureGEO M12 Left

- Position first GEO M12 so that Autorig™ is at the bottom
- Pull the bumper front latches, rotate the lower links so that connection points are double leg and release the latches.
- Position bumper on top of first GEO M12 and lock front points to the bumper with 2 BL820 quick release pins.
- Connect the bumper link bar (0° / "S" position) to GEO M12 rear rigging plate (hole marked "bumper"). Lock with the quick release pin BL0825.

GEO M12 Right

- Position first GEO M12 so that Autorig™ is at the top and set in automatic lock position
- Pull the bumper front latches, rotate the lower links so that connection points are single leg and release the latches.
- Position bumper on top of first GEO M12, front points will lock automatically
- Connect the bumper link bar (0° / "S" position) to GEO M12 rear rigging plate (hole marked "bumper"). Lock with the quick release pin BL0825.
- If flying with bumper only, pull front and rear center latches, and release front and rear bumper connecting points.

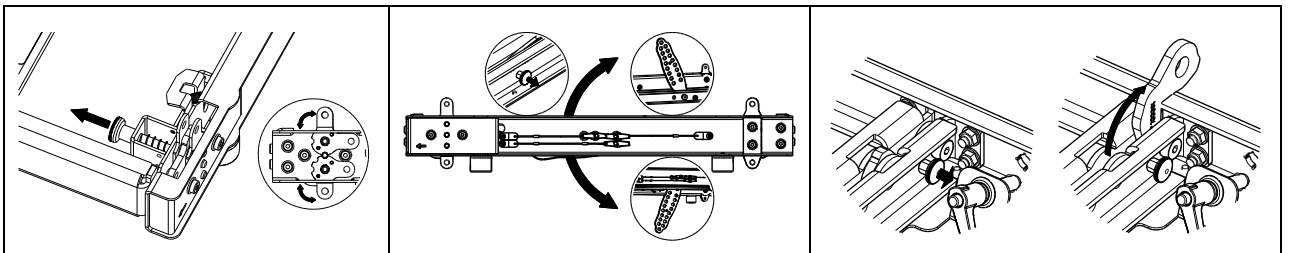

- If required, position VNT-EXBARM12 frontwards or rearwards into VNT-BUMPM12 slots and lock devices with the quick release pins 12x40 stored on VNT-BUMPM12.

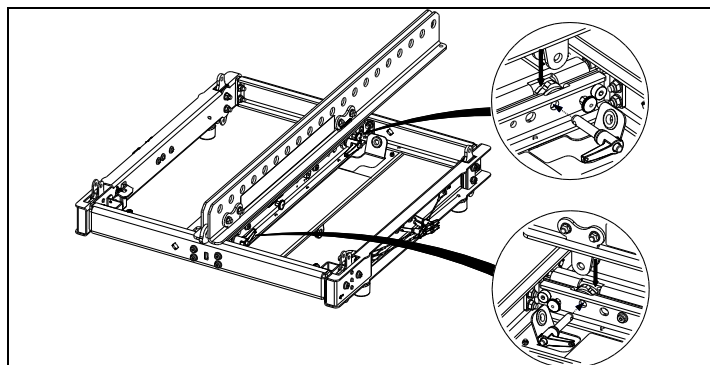

- Insert shackle(s) in bumper or in extension bar in required hole(s) as indicated in NS1 design and secure shackle bolt(s)

- If using 1 hoist on VNT-EXBARM12, holes are “A” to “T”
- If using 2 hoists on VNT-EXBARM12, connect these using extreme holes (“A” and “T”)
- VNT-BUMPM12 without extension bar can only be flown with 2 hoists from front and rear rigging points
- Connect hoist hook(s) to shackle(s) and lift assembly to sufficient height in order to connect a second GEO M12

IMPORTANT

Ensure hoist hook(s) is (are) properly secured to VNT-BUMPM12 or VNT-EXBARM12 shackle(s)

Ensure that all quick release pins are locked

Subsequent GEO M12s

- Position second GEO M12 cabinet with AutoRig™ in automatic lock position, and lock front points to first GEO M12
- Unlock GEO M12 link bar
- Pull the latch to engage the guide in GEO M12 rear slot.
- Adjust the angle by inserting quick release pin BL820 in proper hole.
- Connect subsequent GEO M12 cabinets as with second.

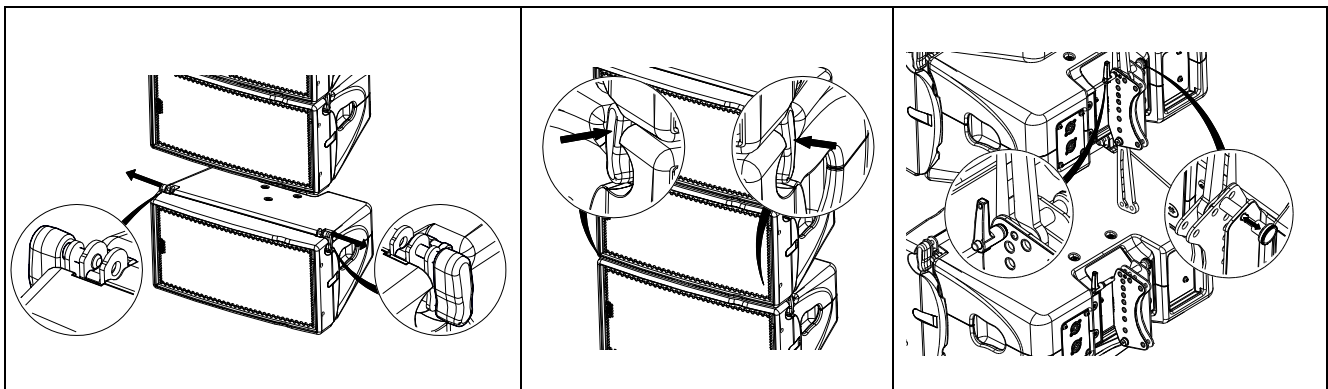

IMPORTANT

Ensure that bumper quick release pins are properly locked into GEO M12, and that all AutoRig™ and rear connecting points are locked

- Lift cluster to NS-1 defined rigging height, secure cluster horizontally to prevent it from rotating;
- Secure bumper with secondary safety steel.

IMPORTANT

The requirements for secondary safety systems vary with territories. However, the secondary safety steel MUST have a SWL equivalent or greater than that of the rigging system.

Disassembly

- While holding GEO M12 to be dismantled, pull AutoRig™ on both sides and hold the side knob (AutoRig™ remains in the open position).
- Remove the rear quick release pin BL820
- Unlock the GEO M12 link bar by pulling the latch.
- Remove GEO M12

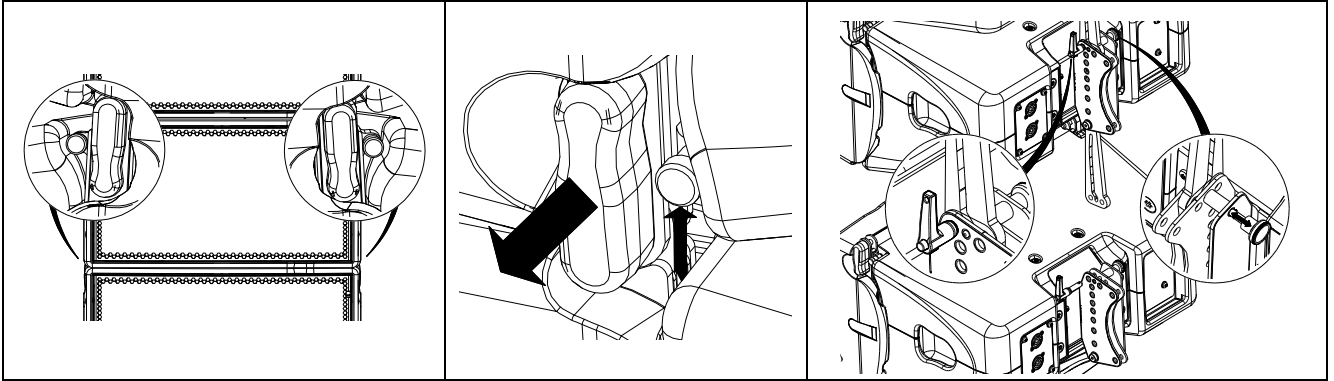

6.4.4 MSUB18 flown with Touring Bumper

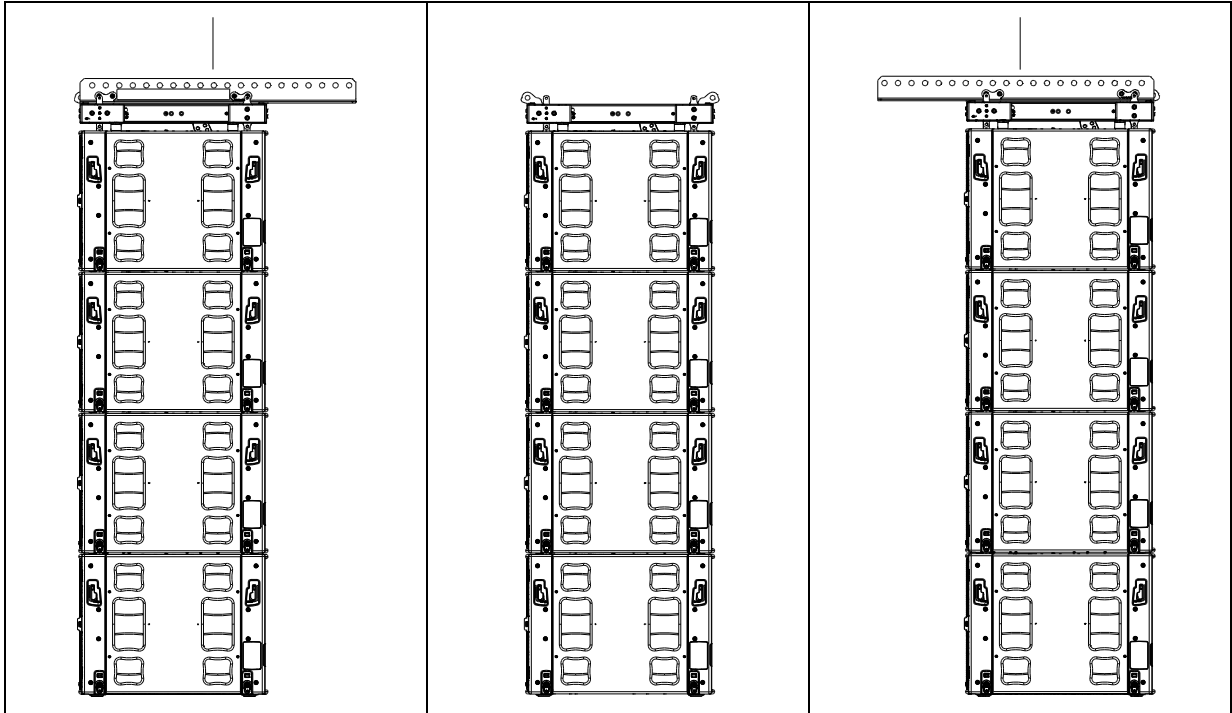

Required items

- 1 or 2 hoists (not provided).
- 1 x VNT-BUMPM12
- 1 x VNT-EXBARM12 to fly on a single rigging point

IMPORTANT

When flying MSUB18 cluster, VNT-BUMPM12 must be set at 0°

- If cluster is flown from 2 points, bumper must be maintained horizontal in its definitive position as well as when lifting or lowering the cluster
- If cluster is flown from a single point, extension bar must be used and hoist connected to "G" position

IMPORTANT

**Maximum MSUB18 quantity for flown vertical cluster with VNT-BUMPM12 is 8.
Please check NS-1 for mechanical Safety Working Load and acoustic computations.**

IMPORTANT

Motor hoist must be rated to support entire cluster weight. Please check configuration in NS-1 for proper motor hoist rating

Procedure

- Position first MSUB18 and unlock front and rear rigging points
- Pull the bumper front latches, rotate the lower links so that connection points are double leg and release the latches.
- Position bumper on top of first MSUB18 and lock front and rear points to the bumper with 2 BL820 quick release pins.
- If flying with bumper only, pull front and rear center latches, and release front and rear bumper connecting points.

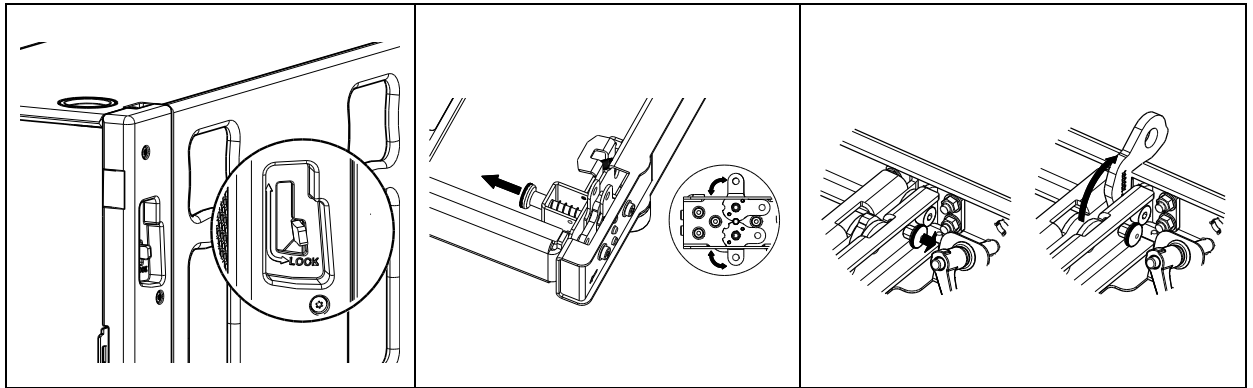

- If flying from a single point, position VNT-EXBARM12 frontwards or rearwards into VNT-BUMPM12 slots and lock devices with the quick release pins 12x40 stored on VNT-BUMPM12.

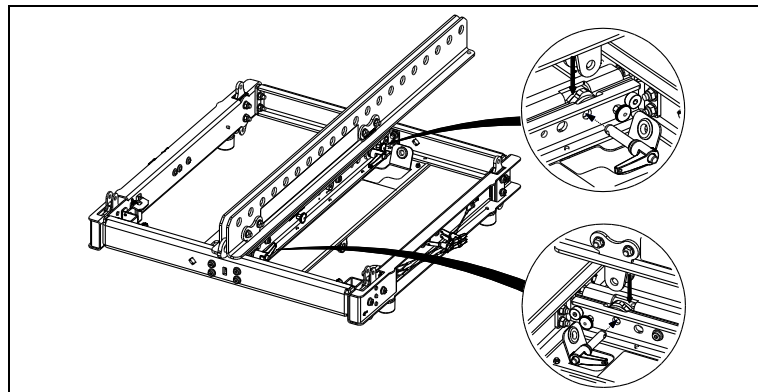

- Insert shackle(s) in bumper or in extension bar in required hole(s), ie:
 - o If using 1 hoist on VNT-EXBARM12, it must be connected to hole "G"
 - o If using 2 hoists on VNT-EXBARM12, connect these using extreme holes ("A" and "T")
 - o VNT-BUMPM12 without extension bar can only be flown with 2 hoists
- Connect hoist hook(s) to shackle(s) and lift assembly to sufficient height in order to connect a second MSUB18;

IMPORTANT

Ensure hoist hook(s) is (are) properly secured to VNT-BUMPM12 or VNT-EXBARM12 shackle(s)

Ensure that all quick release pins are locked

- Release first MSUB18 bottom connecting points latches and unlock second MSUB18 top front and rear rigging points
- Align both MSUB18s rigging points, lower second MSUB18 on first and lock them together
- Connect subsequent MSUB18 subwoofers by unlocking upper points and setting lower points in auto-lock mode.

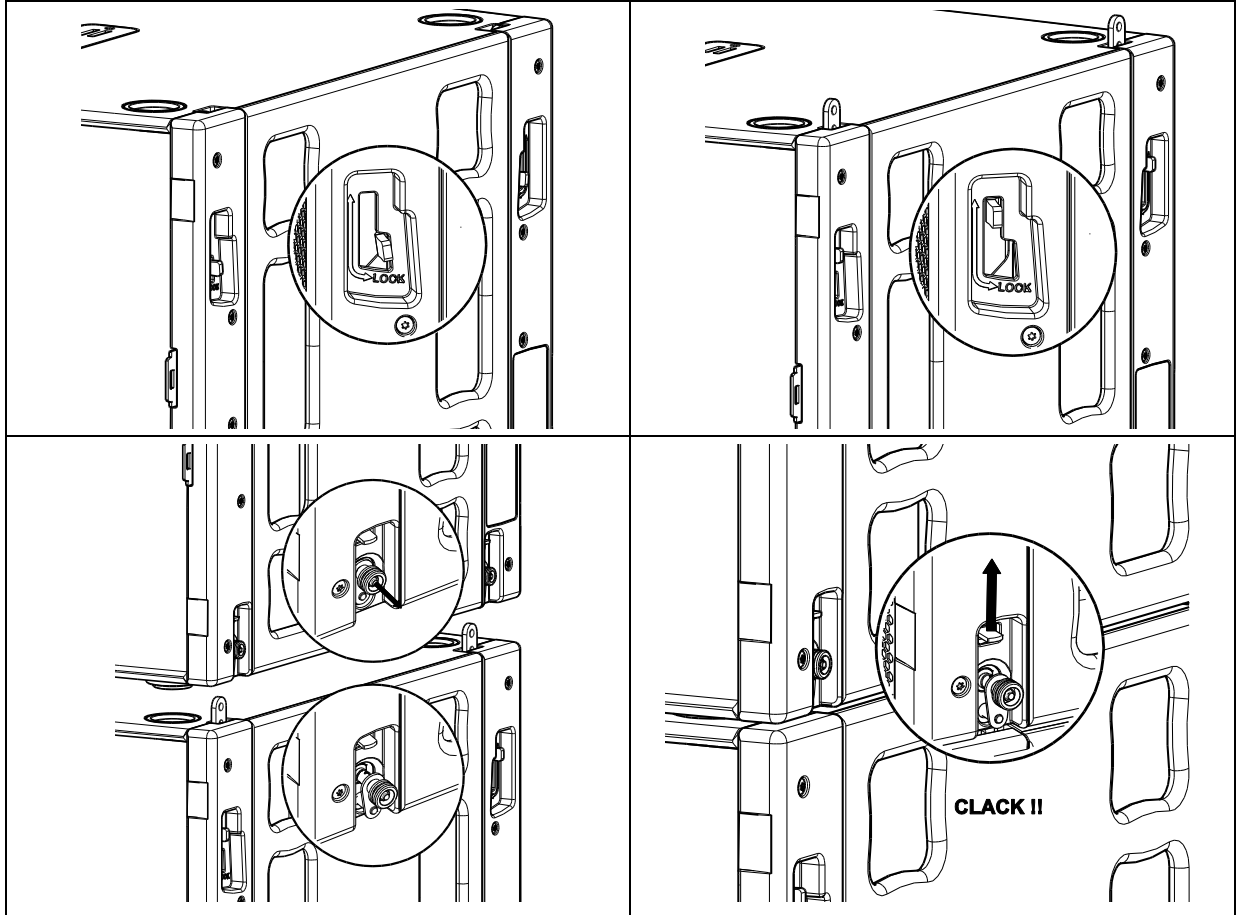

IMPORTANT

Ensure that all connecting points are locked

- Lift cluster to NS-1 defined rigging height, secure cluster horizontally to prevent it from rotating;
- Secure bumper with secondary safety steel.

IMPORTANT

The requirements for secondary safety systems vary with territories. However, the secondary safety steel **MUST** have a SWL equivalent or greater than that of the rigging system.

Disassembly

- Lower MSUB18 cluster on the ground, unlock front and rear rigging points and lift cluster to remove bottom MSUB18.
- Repeat until last MSUB18 is removed
- Disassemble top bumper.

6.4.5 MSUB18 and GEO M12 flown with Touring Bumper

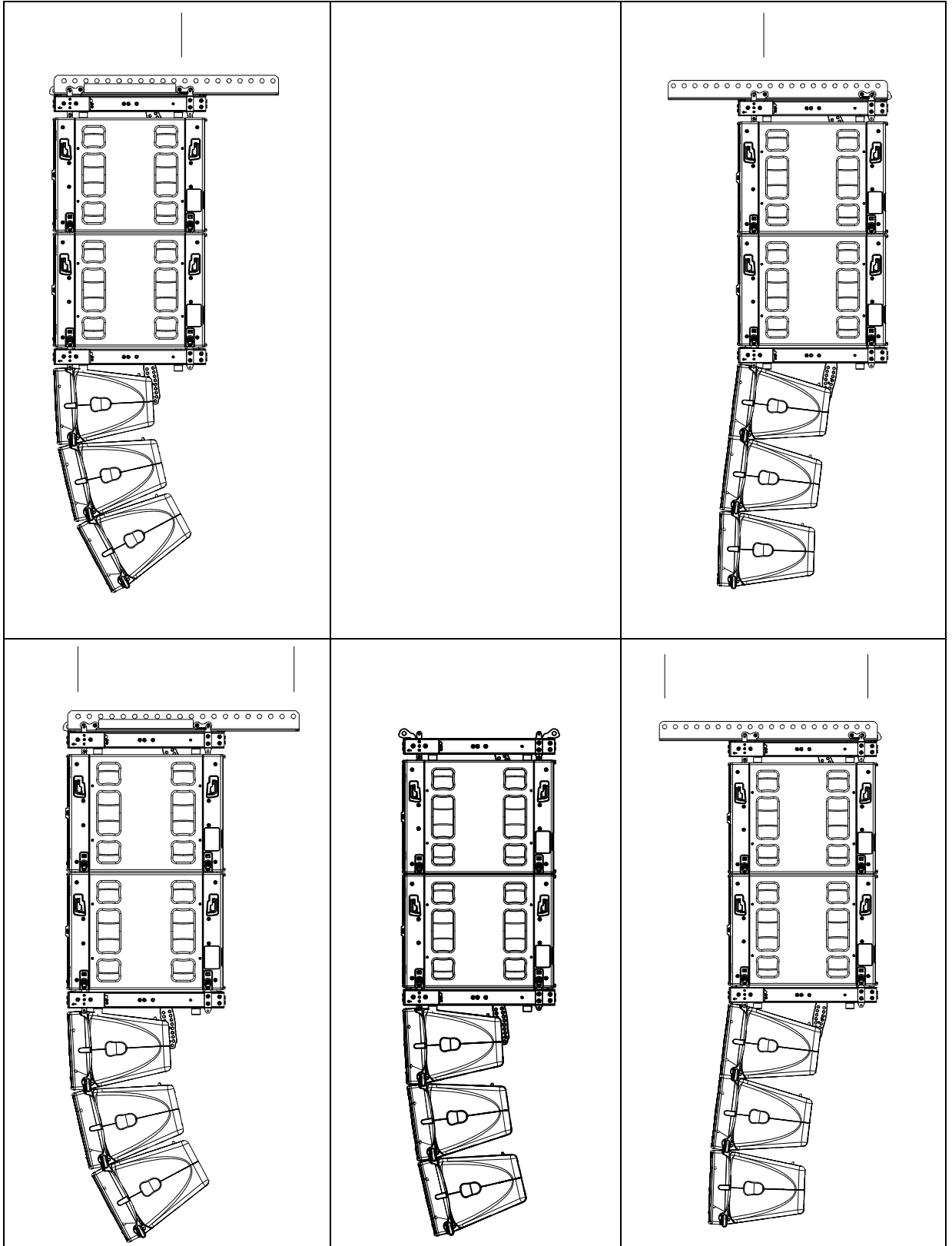

Required items

- 1 or 2 hoists (not provided).
- 2 x VNT-BUMPM12
- 1 x VNT-EXBARM12 for extended positive and negative bumper angles

IMPORTANT

When flying MSUB18 & GEO M12 cluster, VNT-BUMPM12 must be set at 0°

- If cluster is flown from 2 points, bumper must be maintained horizontal in its definitive position as well as when lifting or lowering the cluster
- If cluster is flown from a single point, extension bar must be used and hoist connected to "G" position

IMPORTANT

Maximum quantity for flown vertical cluster with VNT-BUMPM12 is:

$$N_{\text{GEO M12}} + 1.5 * N_{\text{MSUB18}} \leq 12$$

Please check NS-1 for mechanical Safety Working Load and acoustic computations.

IMPORTANT

Motor hoist must be rated to support entire cluster weight. Please check configuration in NS-1 for proper motor hoist rating

Procedure

- Position first MSUB18 and unlock front and rear rigging points
- Pull the bumper front latches, rotate the lower links so that connection points are double leg and release the latches.
- Position bumper on top of first MSUB18 and lock front and rear points to the bumper with 2 BL820 quick release pins.
- If flying with bumper only, pull front and rear center latches, and release front and rear bumper connecting points.

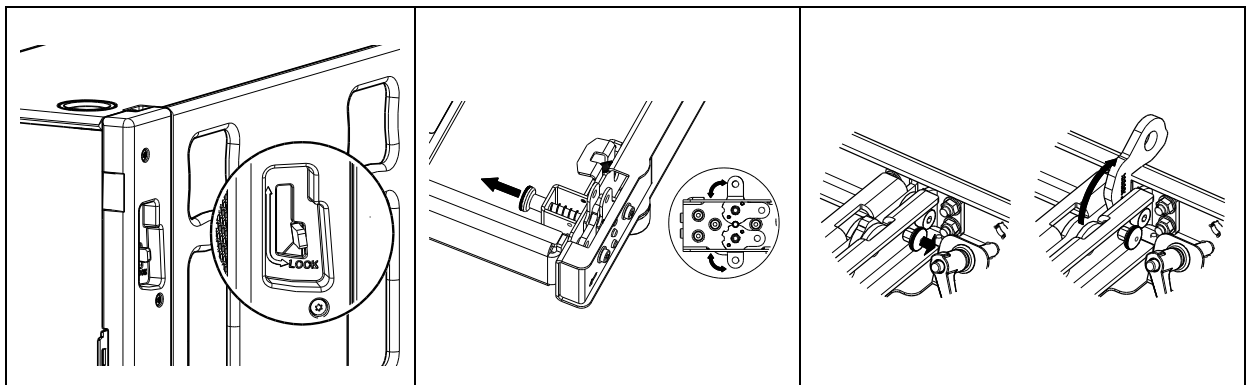

- If required, position VNT-EXBARM12 frontwards or rearwards into VNT-BUMPM12 slots and lock devices with the quick release pins 12x40 stored on VNT-BUMPM12.

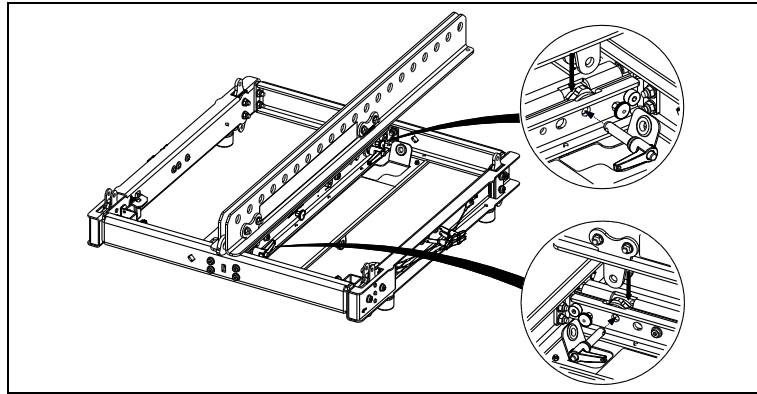

- Insert shackle(s) in bumper or in extension bar in required hole(s), ie:
 - o If using 1 hoist on VNT-EXBARM12, it must be connected to hole "G"
 - o If using 2 hoists on VNT-EXBARM12, connect these using extreme holes ("A" and "T")
 - o VNT-BUMPM12 without extension bar can only be flown with 2 hoists
- Connect hoist hook(s) to shackle(s) and lift assembly to sufficient height in order to connect a second MSUB18;

IMPORTANT

Ensure hoist hook(s) is (are) properly secured to VNT-BUMPM12 or VNT-EXBARM12 shackle(s)

Ensure that all quick release pins are locked

- Release first MSUB18 bottom connecting points latches and unlock second MSUB18 top front and rear rigging points
- Align both MSUB18s rigging points, lower second MSUB18 on first and lock them together
- Connect subsequent MSUB18 subwoofers by unlocking upper points and setting lower points in auto-lock mode.

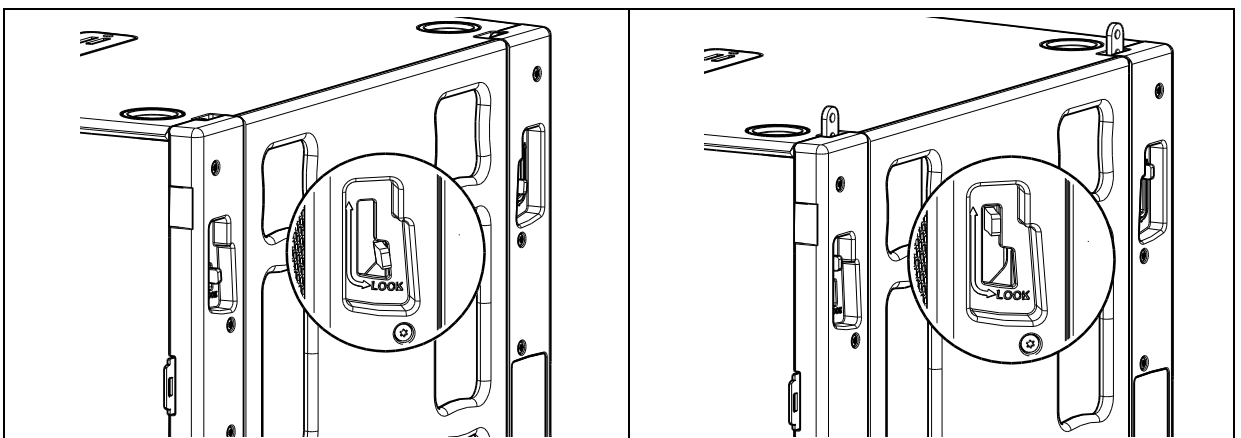

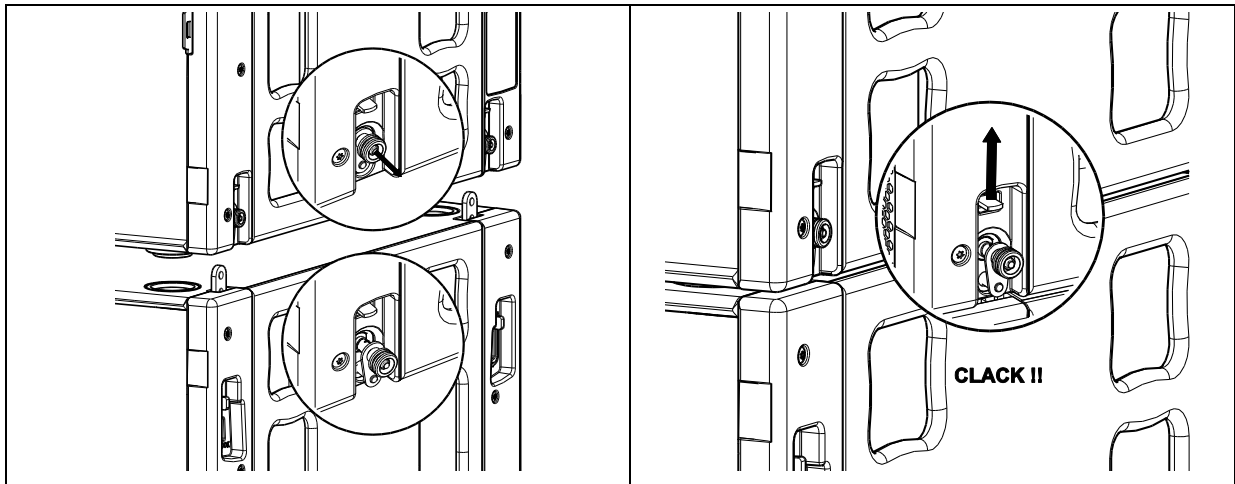

- Once all MSUB18 are off the ground, position second VNT-BUMPM12 below last MSUB18
- Pull bottom bumper front latches, and rotate the upper links so that single leg, and release the latches
- Unlock last MSUB18 top front and rear rigging points
- Connect bottom bumper to last MSUB18 by locking front and rear rigging points

GEO M12 Left

- Position first GEO M12 below bottom bumper so that Autorig™ is at the bottom
- Pull the bottom bumper front latches, rotate the lower links so that connection points are double leg and release the latches.
- Position first GEO M12 below bottom bumper and lock front points to the bumper with 2 BL820 quick release pins.
- Connect the bumper link bar at required angle (selection from -12° to $+12^{\circ}$ in 3° steps) to GEO M12 rear rigging plate (hole marked "bumper") and lock with the quick release pin BL0825.

GEO M12 Right

- Position first GEO M12 so that Autorig™ is at the top and set in automatic lock position
- Pull the bumper front latches, rotate the lower links so that connection points are single leg and release the latches.
- Position bumper on top of first GEO M12, front points will lock automatically
- Connect the bumper link bar at required angle (selection from -12° to $+12^{\circ}$ in 3° steps) to GEO M12 rear rigging plate (hole marked "bumper"), and lock with the quick release pin BL0825.

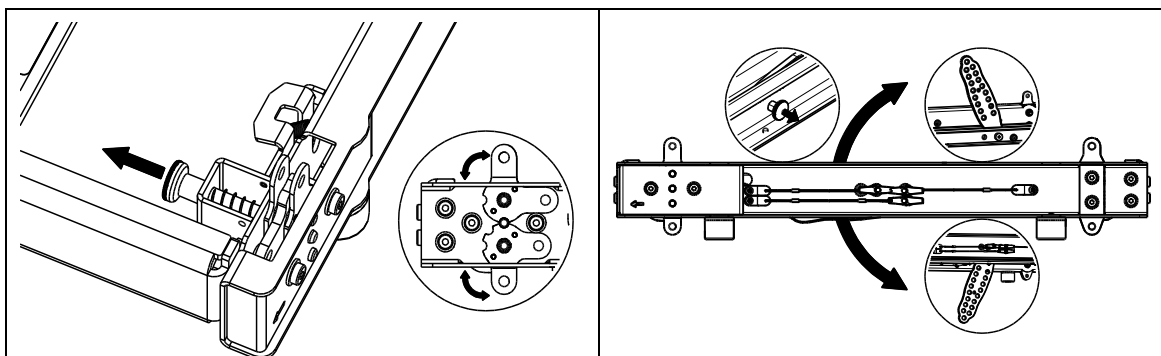

Subsequent GEO M12s

- Lift assembly to sufficient height in order to connect a second GEO M12;
- Position second GEO M12 cabinet with AutoRig™ in automatic lock position, and lock front points to first GEO M12
- Unlock GEO M12 link bar
- Pull the latch to engage the guide in GEO M12 rear slot.
- Adjust the angle by inserting quick release pin BL820 in proper hole.
- Connect subsequent GEO M12 cabinets as with second.

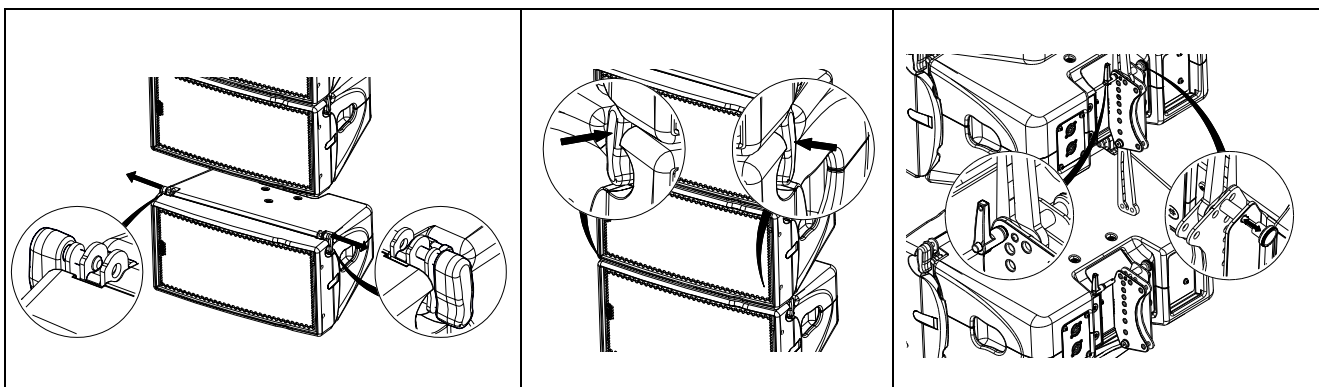
**IMPORTANT**

Ensure that bumper quick release pins are properly locked into GEO M12, and that all AutoRig™ and rear connecting points are locked

- Lift cluster to NS-1 defined rigging height, secure cluster horizontally to prevent it from rotating;
- Secure bumper with secondary safety steel.

IMPORTANT

The requirements for secondary safety systems vary with territories. However, the secondary safety steel MUST have a SWL equivalent or greater than that of the rigging system.

Disassembly

- While holding GEO M12 to be dismantled, pull AutoRig™ on both sides and hold the side knob (AutoRig™ remains in the open position).
- Remove the rear quick release pin BL820
- Unlock the GEO M12 link bar by pulling the latch.
- Remove GEO M12

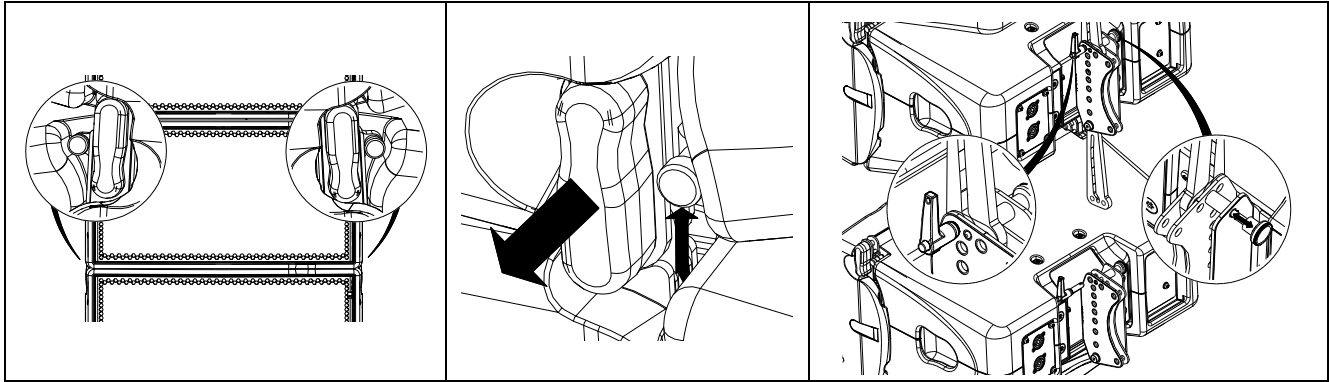

- Once last GEO M12 has been removed, unlock and remove bottom bumper
- Lower MSUB18s on the ground, unlock front and rear rigging points and lift cluster to remove bottom MSUB18.
- Repeat until last MSUB18 is removed
- Disassemble top bumper.

6.5 Permanent Installation variant

All procedures described above apply to installation versions, with the exception of bumper and cabinet connections, which are described below:

Configuring VNI- BUMPM12 for GEO M12-I Left or Right

- Adjust the front rigging point to required configuration and lock with provided screws (screws M8x45, washers M8, brake nuts M8).

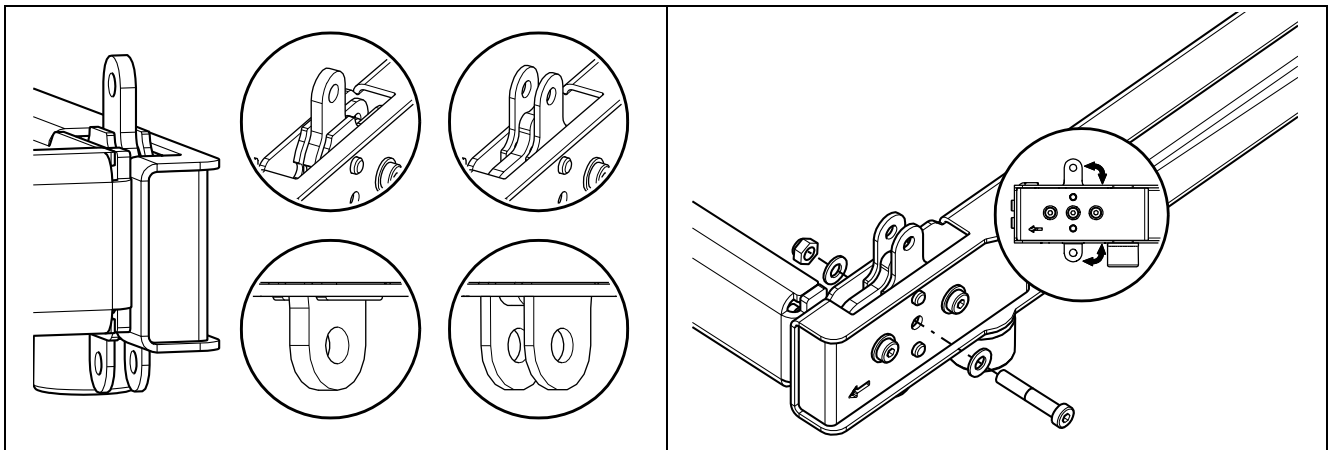

Connecting VNI-BUMPM12 to MSUB18-I

- Place the bumper on MSUB18-I, insert the axis and the washers (M8) and secure with the brake nuts (M8).

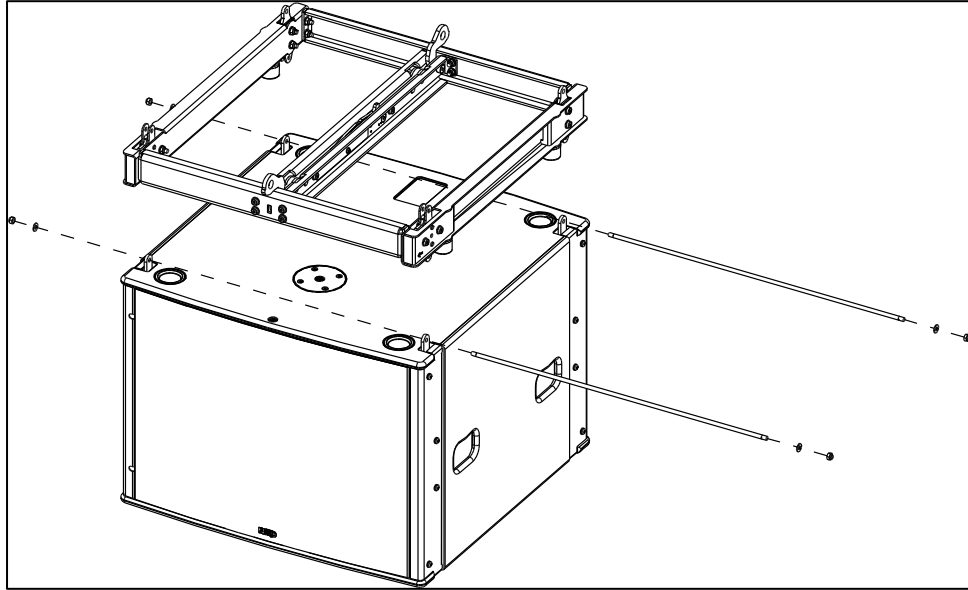
Connecting VNI-BUMPM12 to GEO M12-I

- Place the bumper on GEO M12-I, insert the axis and the washers (M8) and secure with the brake nuts (M8).
- Adjust the appropriate inter-angle value with the linkbar and secure with provided screws (1 shoulder screw D10x20, washer M10, washer M8, brake nut M8)

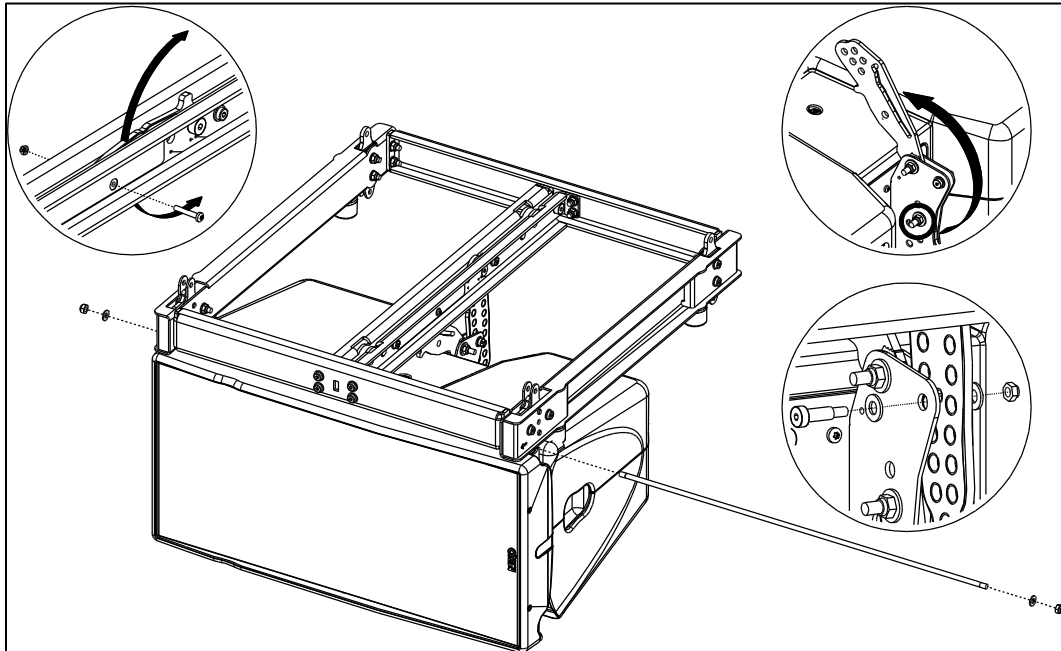

Subsequent MSUB18-I

- Remove the 4 corner plates (Tx30)
- Insert the axis across front and rear rigging points, insert safety clips and secure these by bending their legs
- Connect subsequent MSUB18-I as with second.

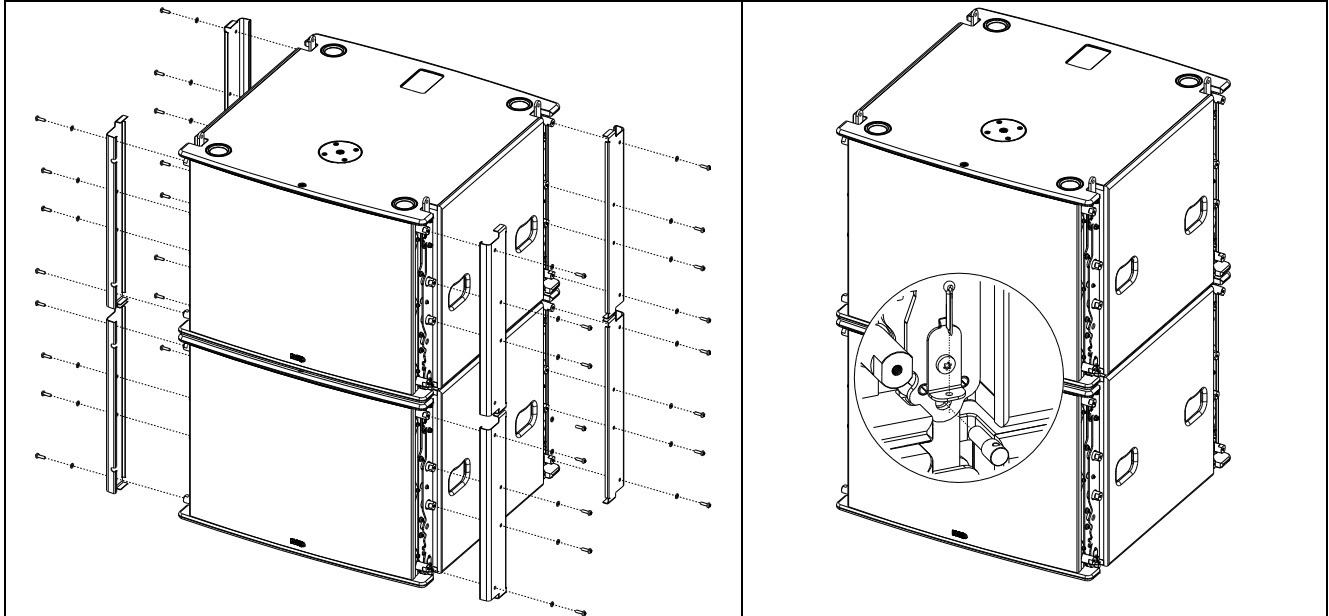
Subsequent GEO M12-I

- Position second GEOM12-I.
- Connect both cabinets by inserting the axis through front holes and secure axis with brake nuts.
- Adjust the appropriate inter-angle value with the linkbar and secure with the provided screws (1 x shoulder screw (D10x20), 2 x washers (M10), 1 x brake nut (M8)).
- Connect subsequent GEO M12-I cabinets as with second.

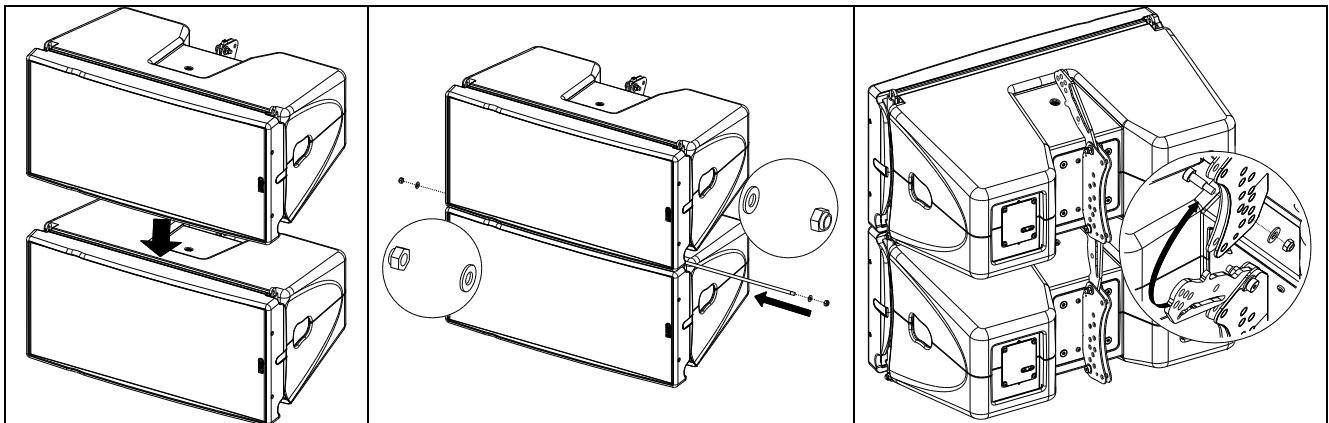

IMPORTANT

Any of the four screws securing the rear rigging plate can be replaced with an eyebolt (M8), connected to sling (apply thread lock on the eyebolt).

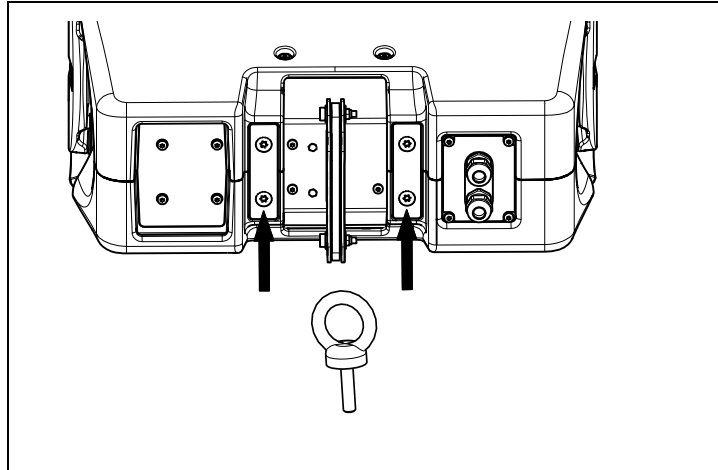

6.6 Testing and Maintenance of the system

General: GEO is a precision piece of equipment and requires regular attention to maintenance in order to give long and reliable service. NEXO recommends regular testing of loudspeaker rigging components, preferably using a suitable test rig coupled with a visual inspection.

Fasteners: there are several critical points in the MSUB18 and GEO M12 cabinets.

Of primary concern are:

- a) The screws or magnets attaching the grid to the cabinet
- b) The machine screws attaching the connecting plates to the cabinet.
- c) The magnets attaching the directivity flanges to the front of the cabinet.

These fasteners should be regularly checked and tightened as necessary.

Cleaning: The exterior of the cabinet and the rigging system can be cleaned with a damp cloth soaked in mild soapy water. On no account use solvent based cleaners, which may damage the finish of the cabinet

After cleaning, the rigging system must be treated with a suitable lubricant to prevent rusting. NEXO recommends the use of Scottoil FS365 which is a water-based lubricant with a mixture of machine oil, surfactant and anti-rust treatment.

7 SYSTEM CHECK ALIGNMENT GUIDELINES

The NEXO TD Controllers factory delay presets are optimised to provide the best possible crossover between the GEO M12 and MSUB18 systems. The reference point for this adjustment is the front of each cabinet. (This means that the internal delays needed to achieve a correct time alignment are set for cabinets standing next to each other with both fronts aligned). We recommend that the system is adjusted so that arrivals from GEO M12 and MSUB18 are coincident at a fairly distant listening position.

7.1 GEO M12 Vertical Cluster design

Cluster design must be done with NS-1, which provides very intuitive and fast method to determine all cluster geometry parameters in relation to venue where cluster is implemented.

NS-1 is a freeware available for all Nexo users at nexo-sa.com

IMPORTANT

Never install a GEO M12 and/or MSUB18 cluster without checking its acoustical performances and mechanical safety in NS-1 prior to installation.

Please contact your local distributor for assistance and/or training NS-1

7.2 Stacked MSUB18 and Flown GEO M12

In the example below, r_1 being the distance from GEO M12 array to listener position, and r_2 being the distance from MSUB18 to listener position, the distance difference is then $r_1 - r_2$ (specified meters or feet).

$r_1 > r_2$, the delay should be set on the MSUB18 NEXO TDcontroller channel.

$r_1 < r_2$, the delay should be set on the GEO M12 NEXO TDcontroller channel

To convert the result in time delay (specified in seconds), apply:

$$\Delta t = (r_1 - r_2) / C \text{ and } r_2 \text{ in meters, } C \text{ (sound speed)} \approx 343 \text{ m/S.}$$

Set the units to meters, feet or seconds according to your preference). Delay will have to be adjusted according to the distance difference $r_1 - r_2$ (see figure below).

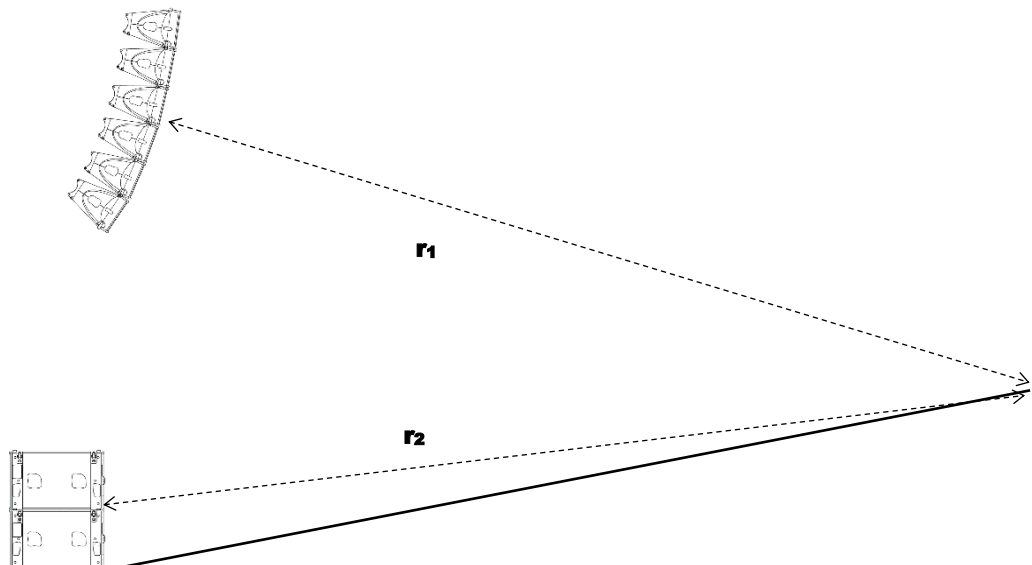

7.3 Driving the MSUB18s from the AUX send

It is quite common to use the AUX send of a mixing desk to drive the Sub section of a PA system. This gives the mixing engineer more flexibility to set the level of the subbass relative to the main PA, apply special effects, or to use a different EQ on the Sub. However, it also raises some serious issues for the performance & safety of the system (mostly time alignment).

At NEXO, great care is taken to design optimum phase alignment from one octave above to one octave below the crossover frequency point. By doing so, drivers are working perfectly together and providing the best efficiency possible. It is then up to the user to adjust the delay on the NEXO TD Controllers to match the physical path difference of the different systems. It is thus possible to get a well-adjusted system, even without measuring instruments.

If MSUB18s are driven from an AUX output, NXAMPs are fed with two signals coming from different sources. If those two sources (MAIN output & AUX send) are not exactly in phase, delay is introduced into the crossover between the GEO M12 array and the MSUB18s. It is then mandatory to use proper measurement tool to optimize phase response.

Why is it unlikely that AUX and MAIN outputs have the same phase?

- Signal paths are likely to be different; any filter modifying the bandwidth and EQ of the signal is also affecting the phase.
Example: a 24dB/oct high pass filter set at 15Hz is affecting amplitude of the signal by only 0.6dB at 30Hz, but the phase shift is 90°!! At 100Hz we can still measure 25° of phase shift.
- Limiting bandwidth with a low pass filter can introduce a phase difference of up to 180° (completely out of phase) at the cross over point.
- If the signal is passing through any digital equipment, between 1.4ms and 2.2ms is being added (around 70° phase shift at 100Hz) due solely to the converter delay! The additional delay due to the processing itself (look ahead compressor, delay...) can be quite important as well.

If both outputs are not measured in the actual configuration, it is very likely that phase alignment will not be correct.

Consequences of badly aligned systems

Mis-aligned systems have lower efficiency: i. e. for the same SPL the system will have to be driven harder, activating the displacement & temperature protection at lower output levels. Both sound quality and reliability will decrease as the system is stressed.

Precautions & Checks

Before using the AUX of a mixing desk, ensure that MAIN and AUX outputs are in phase;

Always apply identical EQ or processing on both channels, so that the phase relationship will not be altered;

Never add additional low pass filtering on the SUB or high pass filtering on the main system;

Inverting polarity on one channel should always result in a massive difference near the crossover point. If that is not the case, the system is no longer aligned.

7.4 Recommended installation tools and equipment

Tape measure – should be 30m/100ft in length and be of durable fibre material. Have one per array available to speed up the installation process.

Spirit level – used to ascertain the trueness of the surface from which the angle measurements originate.

Rangefinder measuring device – either a Disto type laser measure or an optical laser rangefinder can be used. Devices such as the Bushnell 'Yardage Pro' sports rangefinders provide sufficiently accuracy and are easy to use. They have the additional advantage of working very well in bright sunlight.

Electronic calculator with trigonometric functions to calculate the height from ground level to points in the room. The formula to calculate height of a point from measured angle and distance is:

Height of point = Sin (vertical angle in degrees) x distance to point

NB: Take care when using spreadsheets as they calculate using radians by default. To convert degrees to radians, use the formula:

Angle (in radians) = 3.142 x Angle (in degrees)/180

Computer – Laptop or Desktop PC running Windows 8 with the current version of NEXO NS-1 installed. It is not possible to configure a GEO tangent array properly without using NS-1. Note that, when NS-1 designs are prepared prior to arrival at the venue, it is often necessary to modify or update the design to accommodate special circumstances. A PC is absolutely essential to make such changes.

Audio Analysis Software – recommended but not absolutely essential, programs such as Systune™, Smaart™ enable rapid and detailed analysis of the installation. Consider taking a training course in using one of these tools if you are not already competent with them – it will pay dividends in increased performance of the system.

7.5 GEO M12 – MSUB18 System Check List

It is essential to execute all these check steps prior to perform a sound check on the “front end” to the system. Following this checklist step by step will prevent many troubles and will save time in the end.

Are the speakers properly connected and angled?

Attach the first series of modules to the bumper.

Before flying, verify that all channels of all modules are functioning properly.

To check that all elements have the proper amplitude and phase, you should listen to the upper boxes at a close distance (<1 meter). You should be able to move from the top to the bottom of the cluster without hearing any change in the tonal balance.

Verify that the angle settings are the same on both sides of each module.

Raise the bumper, attach the next series of modules and repeat the above checks.

Make sure that these series of modules sum properly with the modules above them.

When all the modules are flown, check that the aiming angles are the same left and right.

Make sure that multiple GEO M12 and MSUB18 are summing properly: 6 dB gain per doubling of quantity.

Final Pre-Sound Check Check

Play a CD track mono left, and then right: both sides must sound strictly identical. When listening in the centre between Left and Right GEO M12s, everything from LF to HF should be located to the “phantom centre” position. If not, repeat the above check sequence to identify the source of the problem.

8 TECHNICAL SPECIFICATIONS

8.1 MSUB18 Subwoofer

8.1.1 System specifications

MSUB18	
MSUB18 WITH NEXO PROCESSING	
Frequency Response @ -6 dB	32 Hz to 120 Hz
Sensitivity 1W@1m	107 dB SPL Nominal
Peak SPL@1m	139 dB
Available Crossover Frequencies	32-65, 32-75, 32-85, 32-95, 32-120 Hz
Nominal Impedance	4 Ohms
Recommended Power	2000 Watts
PRODUCT FEATURES	
Component	1 x 18" 4 Ohms very long excursion Neodymium driver
Height x Width x Depth	525 mm x 701 mm x 704 mm (20.6" x 27.6" x 27.7")
Weight: Net	55 kg (121 lb)
Connectors (Touring version)	4 x NL4, 4 poles connectors (1+/1- MSUB18 / 2+/2- Through)
Connectors (Install version)	2 x Cable gland with 2 cores cables
Construction	Baltic Birch Plywood & textured black or white coating
Fittings	8 x Side handles
Front Finish (Touring version)	Steel front grill + back mesh
Front Finish (Install version)	Acoustic fabric fitted from grill
Operating temperature range	0°C – 40°C
Storage temperature range	-20°C – 60°C
SYSTEM OPERATION	
Recommended powering solution	NXAMP4x4 Powered TD controller: 2 x MSUB18 per channel
Optional powering solution	NXAMP4x2mk2 Powered TD controller: 1 x MSUB18 per channel
	NXAMP4x1mk2 Powered TD controller (Bridged): 1 x MSUB18 per channel

8.1.2 Dimensions (mm/inches)

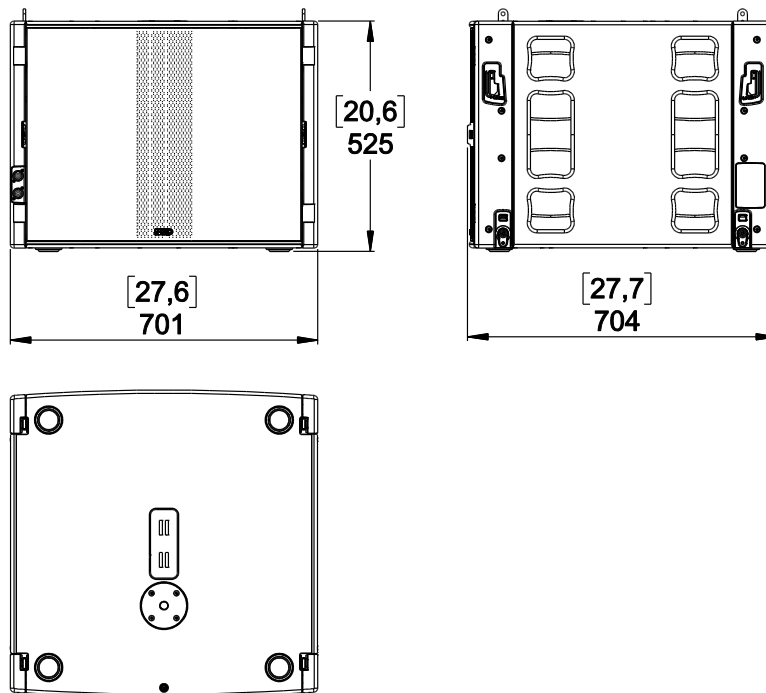

8.2 GEO M1210 & GEO M1220

8.2.1 System specifications

	GEO M1210 (without CDD™)	GEO M1210 (with CDD™)	GEO M1220 (without CDD™)	GEO M1220 (with CDD™)
GEO M12 WITH NEXO TDCONTROLLER SETUP				
Frequency Response @-6 dB	50 Hz to 20 kHz			
Sensitivity 1W@1m	105 dB SPL Nominal			
Peak SPL@1m	140 dB			
Vertical Dispersion	10°		20°	
Horizontal Dispersion	80°	120°	80°	120°
Passive Crossover Frequency	1.1 kHz			
Nominal Impedance	Active mode : (8 Ω LF + 16 Ω HF) / Passive mode : 8 Ω			
Recommended Power	Active mode : (1250 Watts LF + 625 Watts HF) / Passive mode : 1250 Watts			
PRODUCT FEATURES				
LF Component	1 x 12" 8 Ohms long excursion Neodymium driver with PDD™			
HF Component	1 x 3" voice coil 1.4" throat driver on a BEA/FEA optimized HR Wavesource™			
Height x Width x Depth	370 mm x 700 mm x 446 mm (14.6" x 27.6" x 17.6")			
Weight: Net	34 kg (75 lb)			
Connectors (Touring version)	2 x NL4, 4 poles connectors (1+/1- Through, 2+/2- GEO M12 in passive mode, 1+/1- LF, 2+/2- HF in active mode)			
Connectors (Install version)	2 x Cable gland with 4 cores connectors			
Active / Passive mode selection	Ruggedized, recessed, waterproof 2 positions switch			
Construction	Lightweight Polyurethane Composite			
Fittings	2 x Side handles horizontal + back grip			
Front Finish (Touring version)	Steel front grill + back mesh			
Front Finish (Install version)	Acoustic fabric fitted front grill			
Operating temperature range	0°C – 40°C (32°F – 104°F)			
Storage temperature range	-20°C – 60°C (-4°F – 140°F)			
Recommended powering solution	NXAMP4x4 Powered TD controller: up to 3 x GEOM12 in passive mode per channel			
Optional powering solution	NXAMP4x2mk2 Powered TD controller: 1 x GEOM12 in passive mode per channel			
	NXAMP4x1mk2 Powered TD controller (Bridged): up to 2 x GEOM12 in passive mode per channel			

8.2.2 Dimensions (mm/inches)

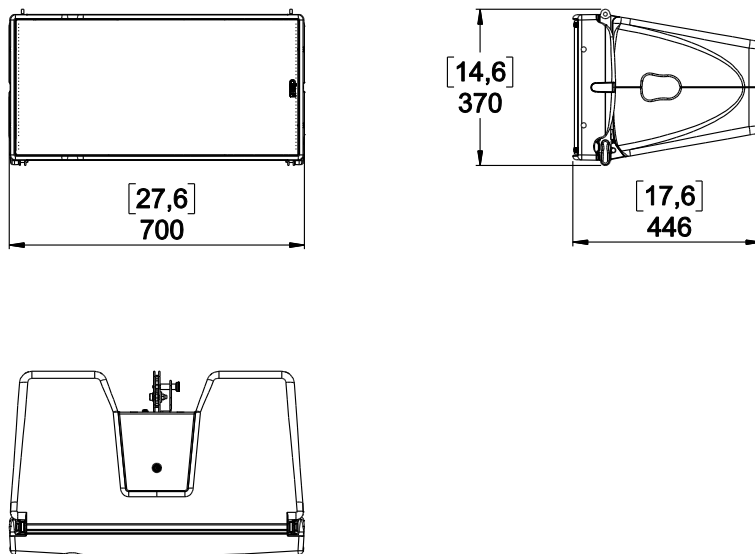

8.3 GEO M12 accessories

8.3.1 VNT-BUMPM12

Parts

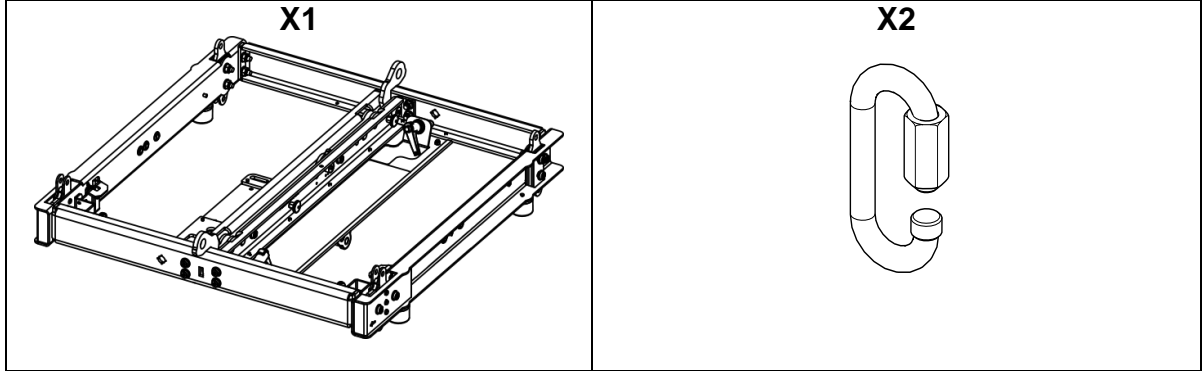



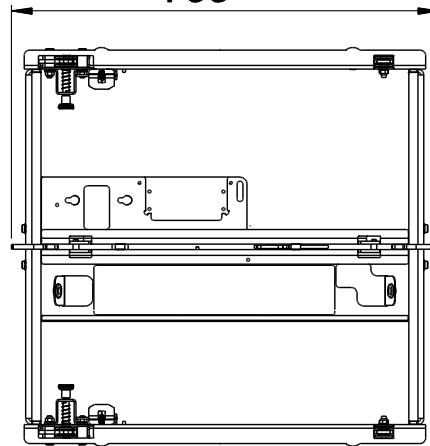
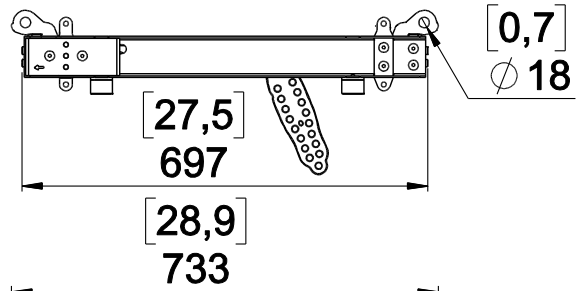
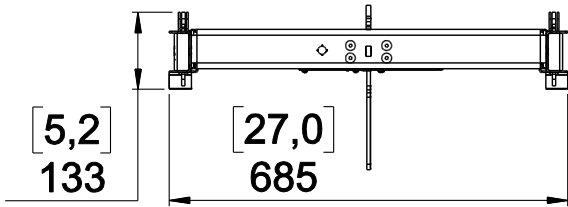





Dimensions

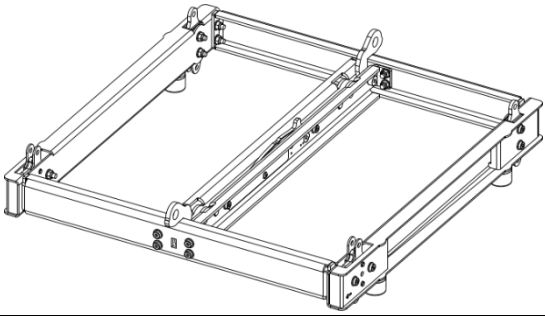

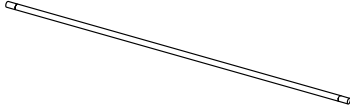
Weight: 22 kg / 48.5 lb

8.3.2 VNI-BUMPM12

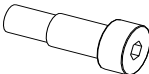
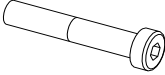
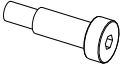
Parts

X1		X2	X3
			
X9 M8	X9 M8	X2 M10	X2 D12x20
			
X2 M8x45	X1 D10x20	X1 M6	X2 M10
			

Dimensions

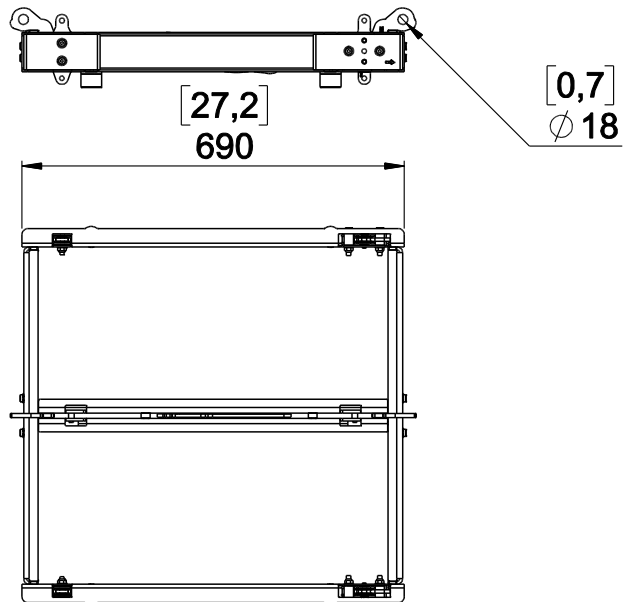
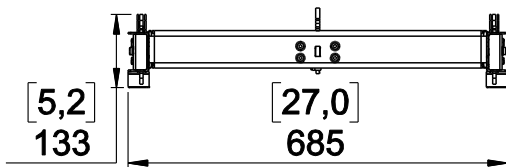

Weight: 20 kg / 44 lb

8.3.3 VNT-EXBARM12

Parts

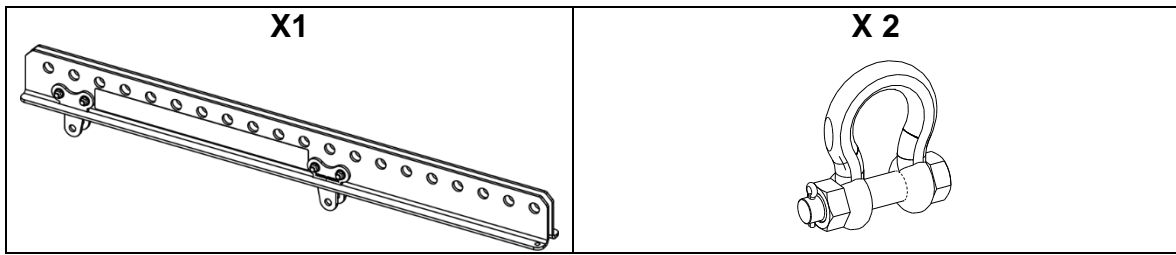

Dimensions

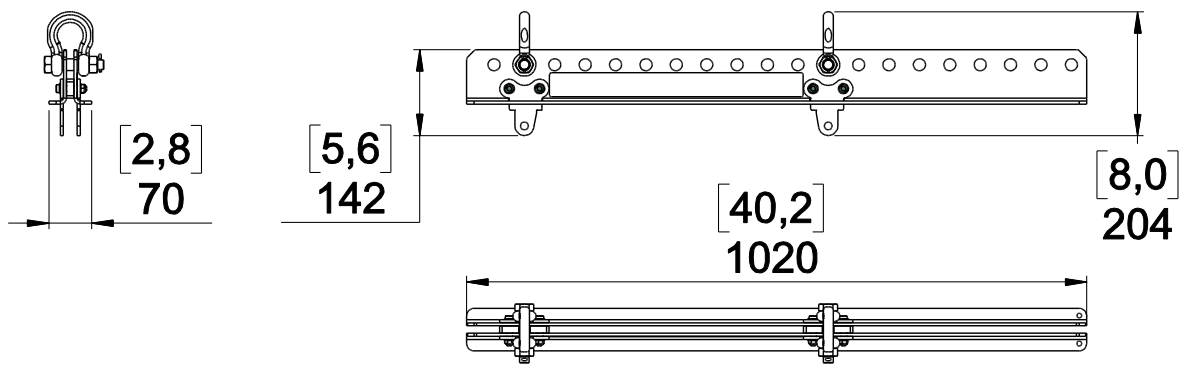

Weight: 11 kg / 25.4 lb

8.3.5 VNT-GSTKM10M12L

Parts

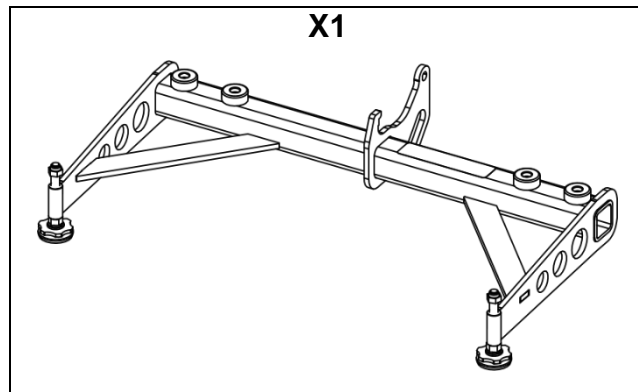

Dimensions

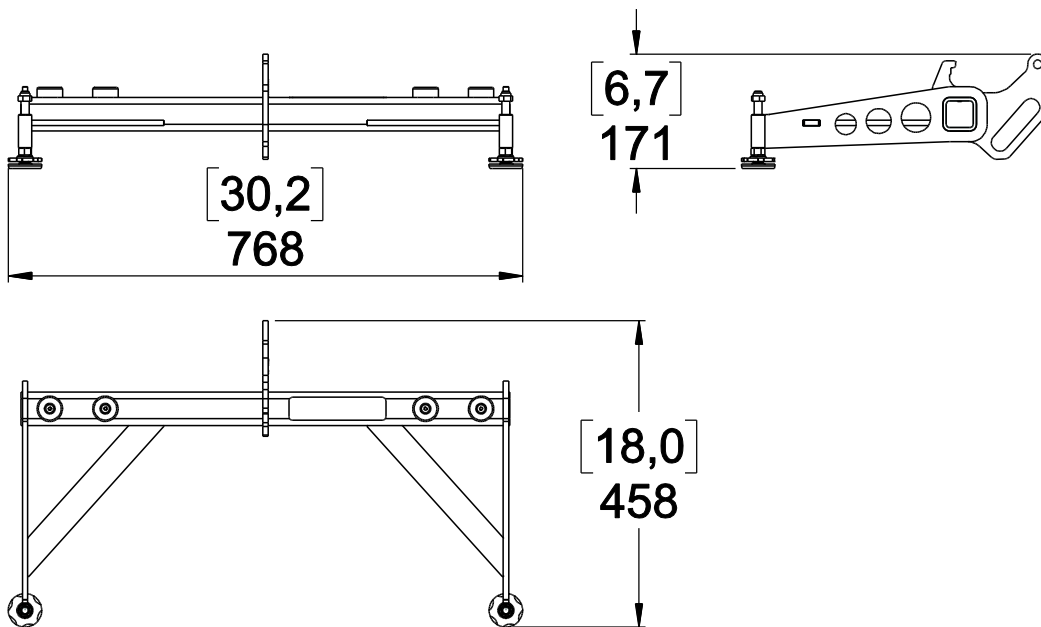

Weight: 9.7 kg / 19.8 lb

8.3.6 VNT-GSTKM10M12S

Parts

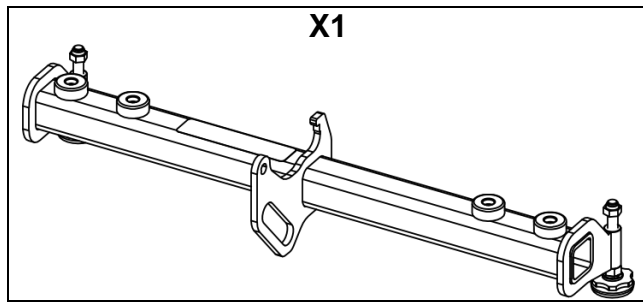

Dimensions

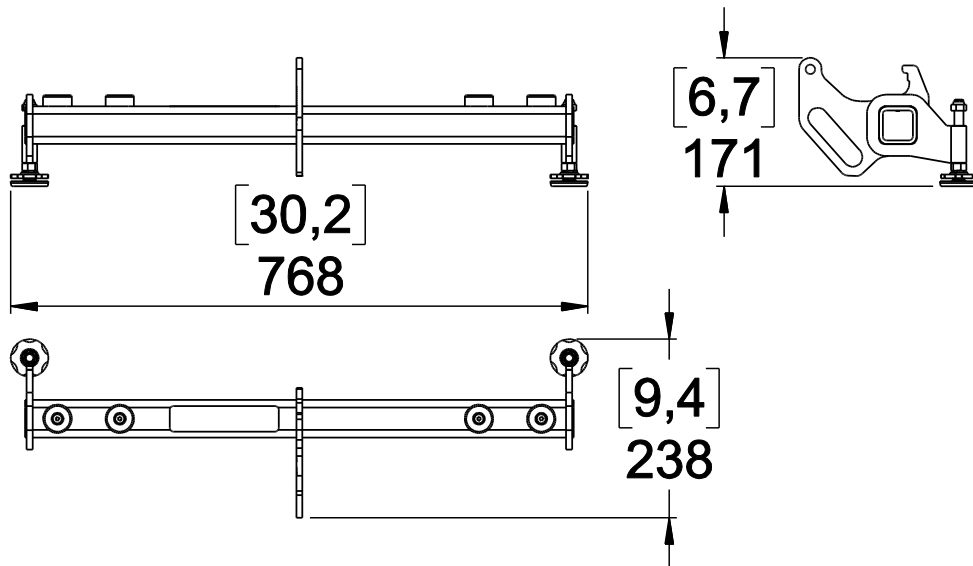

Weight: 7 kg / 15.4 lb

8.3.7 VNT-MNSTKM12

Parts

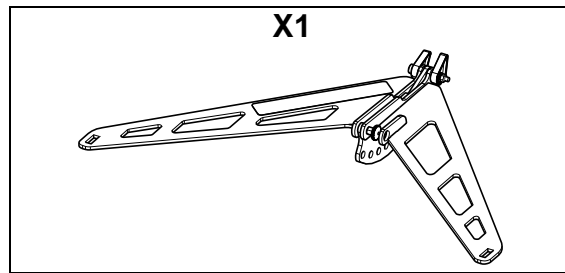

Dimensions

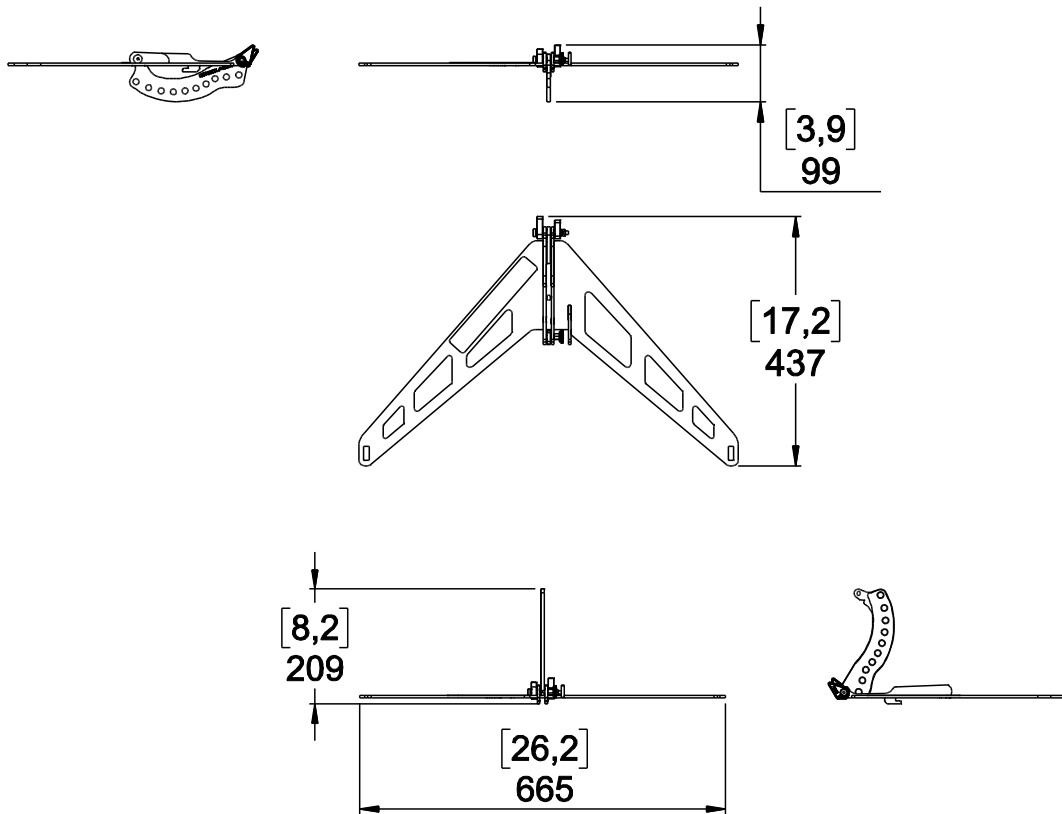

Weight: 3 kg / 6.6 lb

8.3.8 GMT-LBUMPM12

Parts

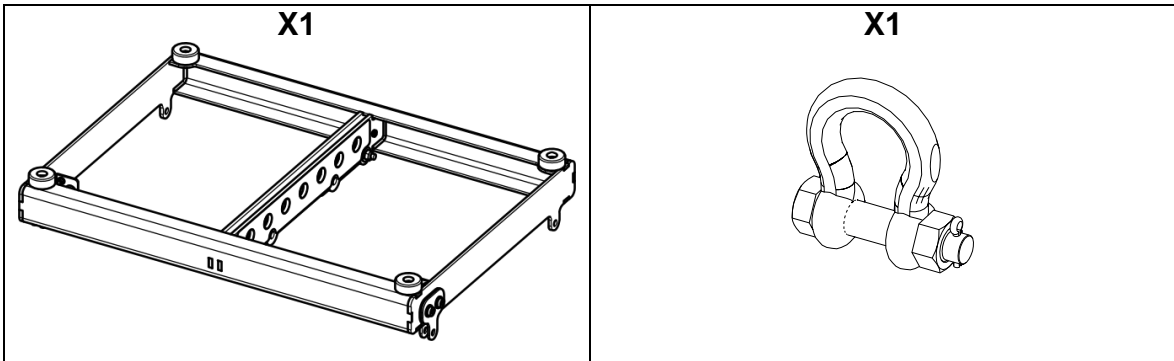

Dimensions

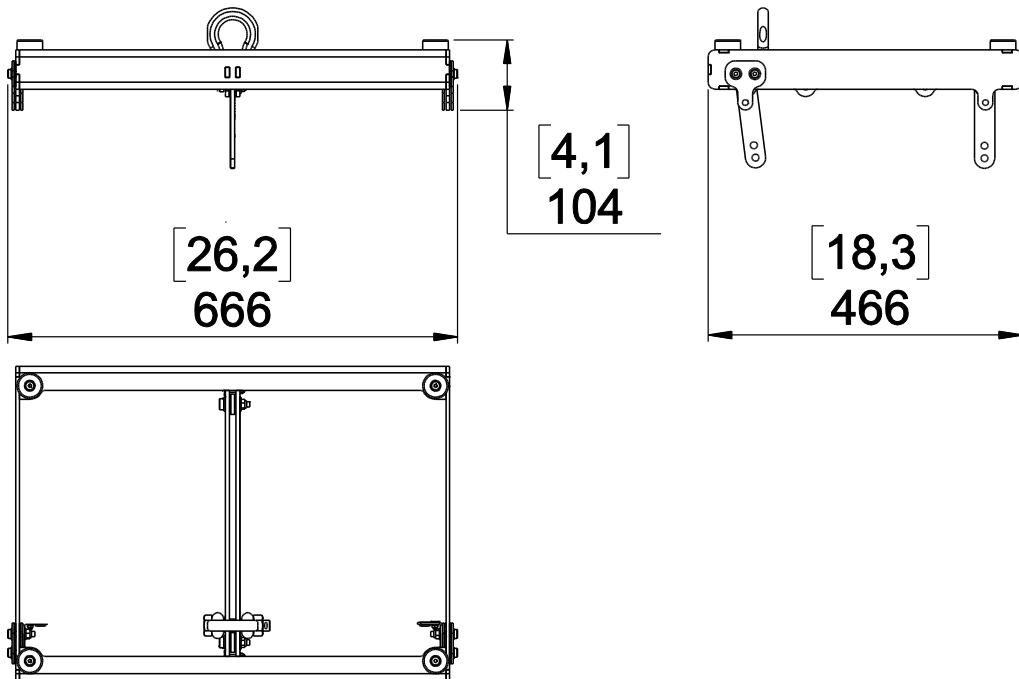

Weight: 10.5 kg / 23.1 lb

8.3.9 GMT-EXBARM12L

Parts

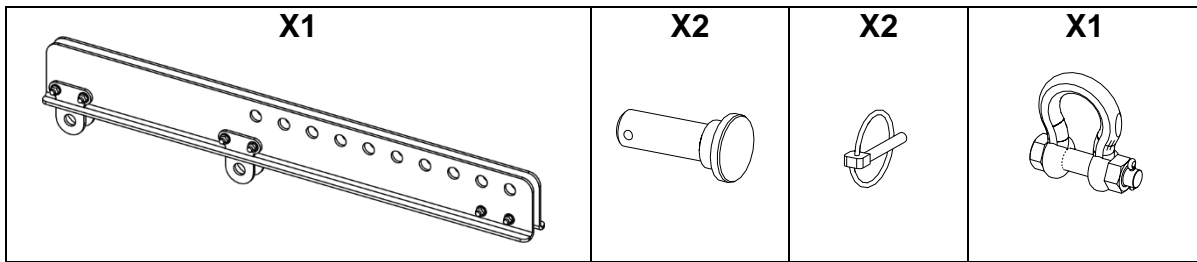

Dimensions

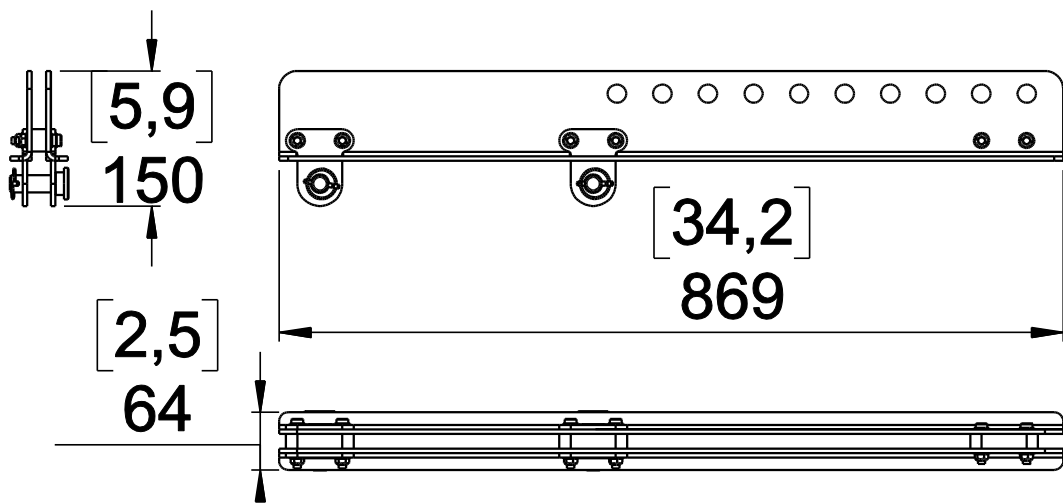

Weight: 9.7 kg / 21.4 lb

8.3.10 GMT-FLGM12

Parts

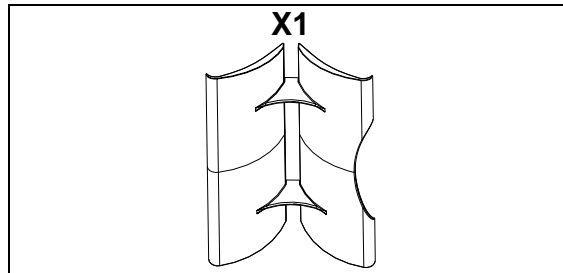

Dimensions

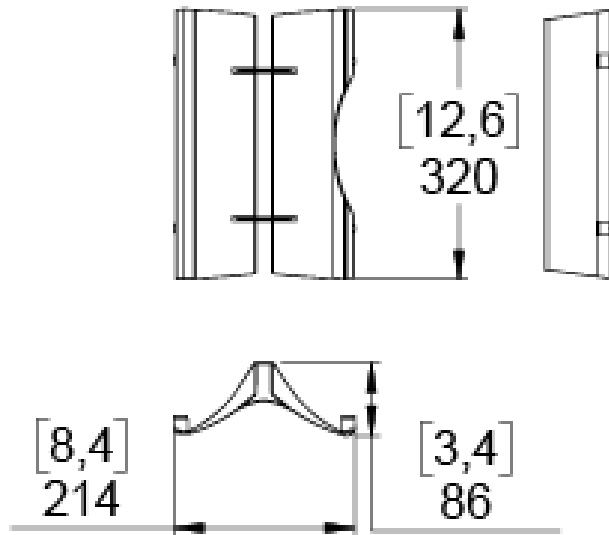

Weight: 1 kg / 2.2 lb

8.3.11 MST-WBMSUB18

Parts

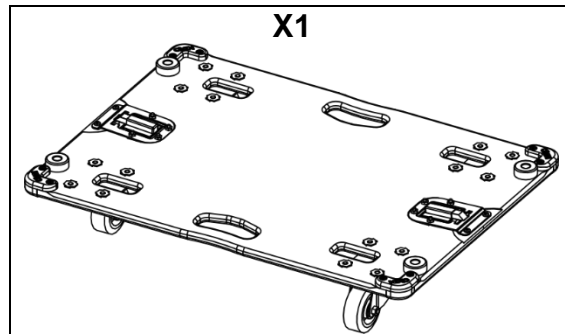

Dimensions

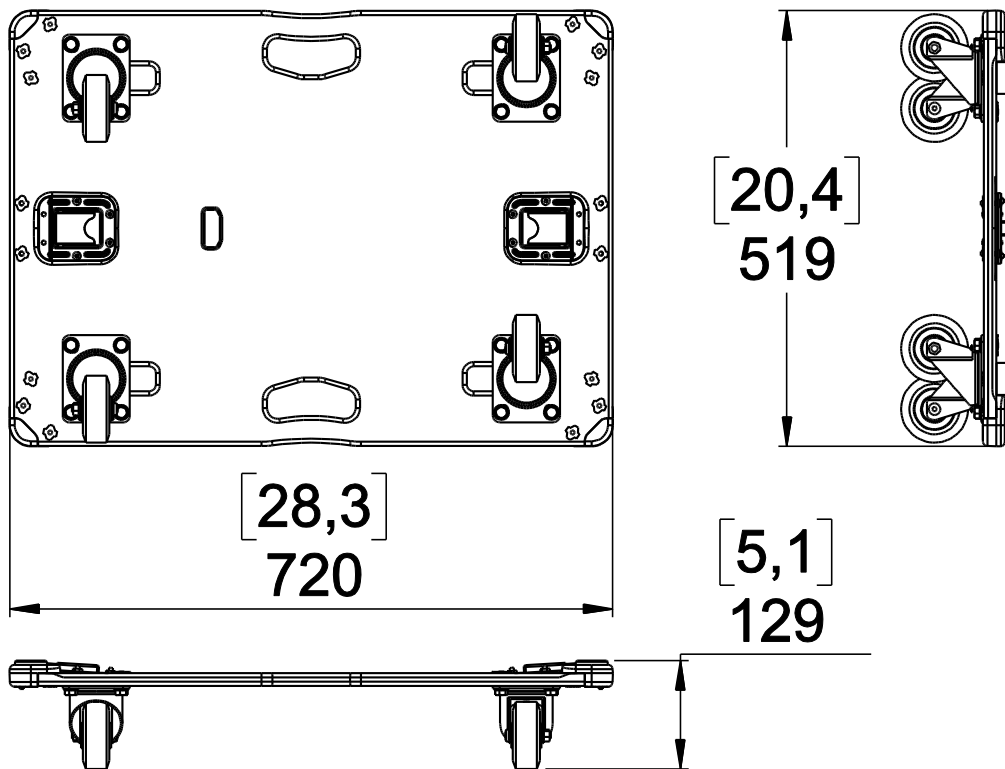

Weight: 7.2 kg / 15.9 lb

8.3.12 MST-DOLLYMSUB18

Parts

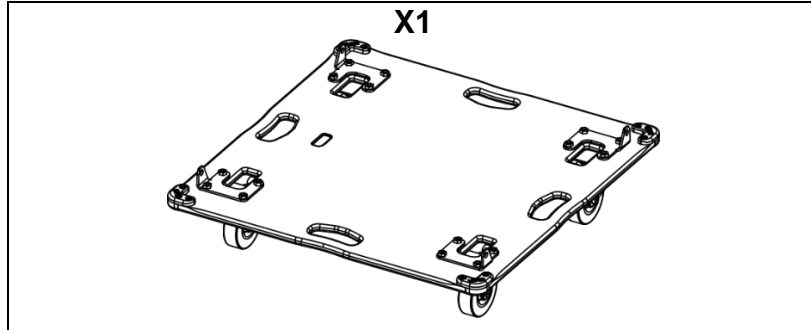

Dimensions

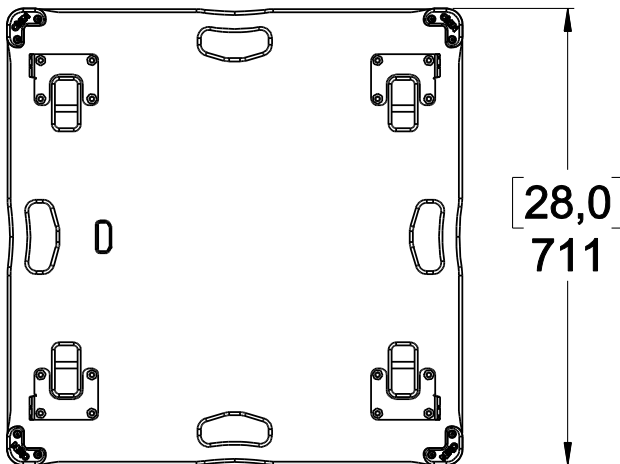
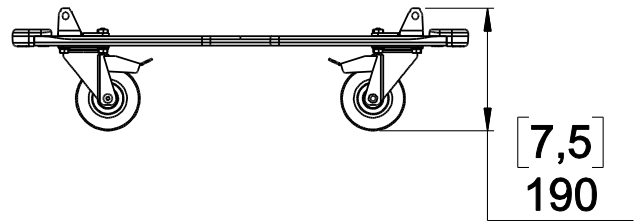
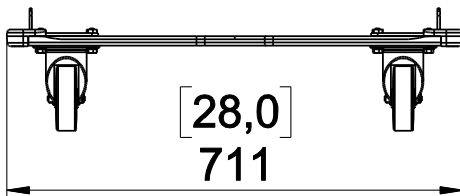

Weight: 10 kg / 22 lb

8.3.13 MST-COVMSUB18

Parts



Weight: 2.2 kg / 5 lb

8.3.14 MST-COV2MSUB18**Parts****Weight: 3.5 kg / 7.7 lb**

8.3.15 GMT-2CASEM12

Parts

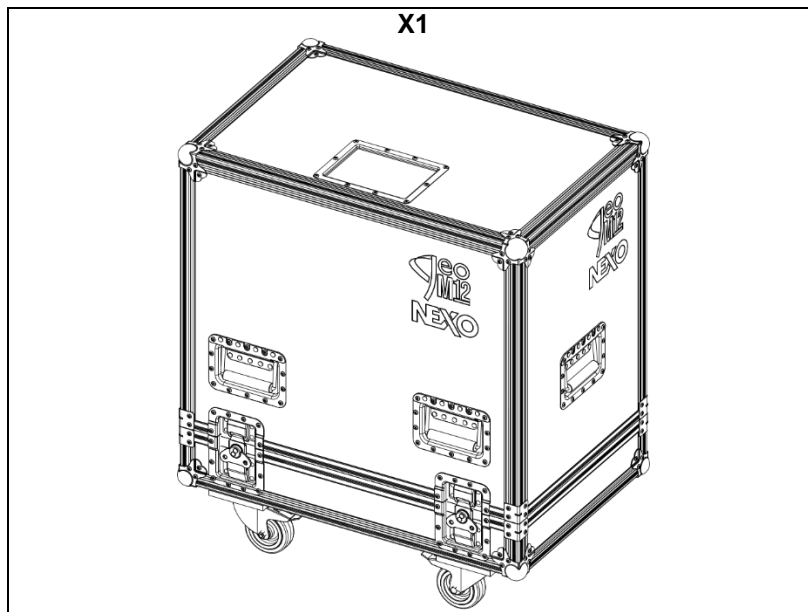

Dimensions

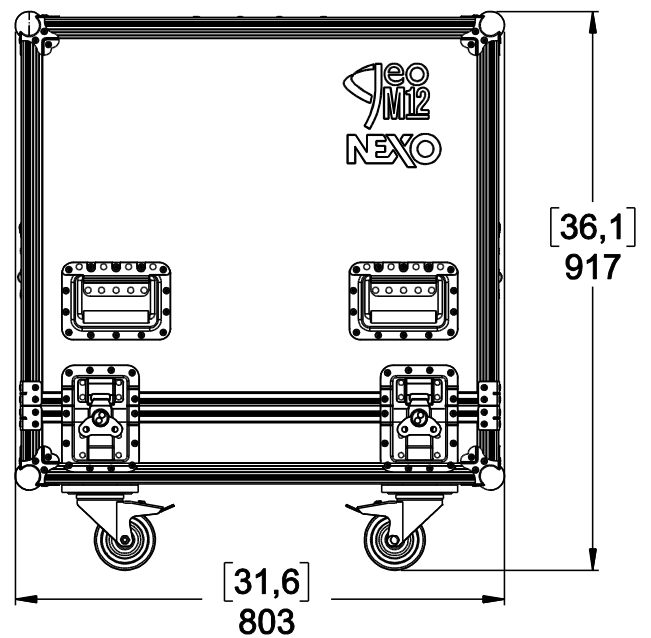
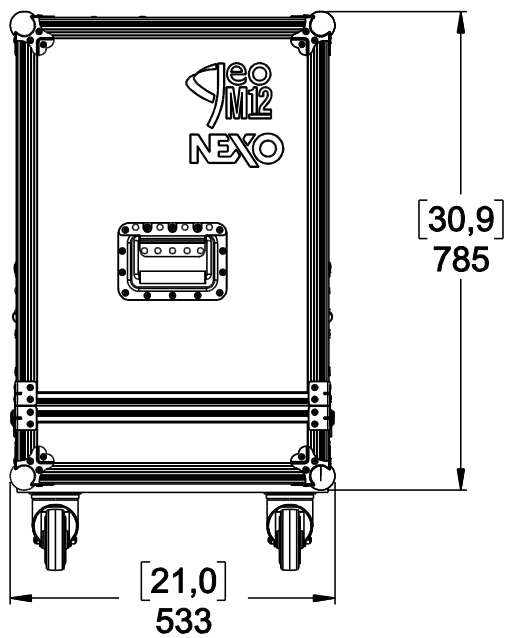

Weight: 35 kg / 77 lb

8.3.16 GMT-3CASEM12

Parts

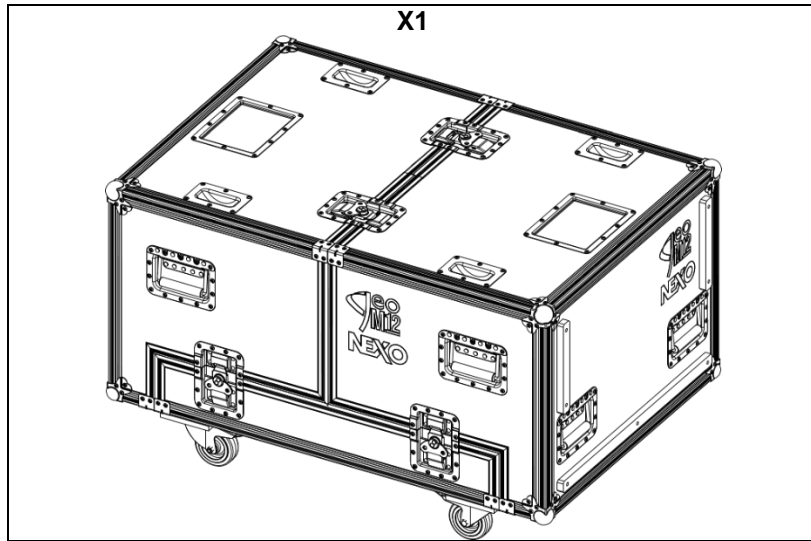

Dimensions

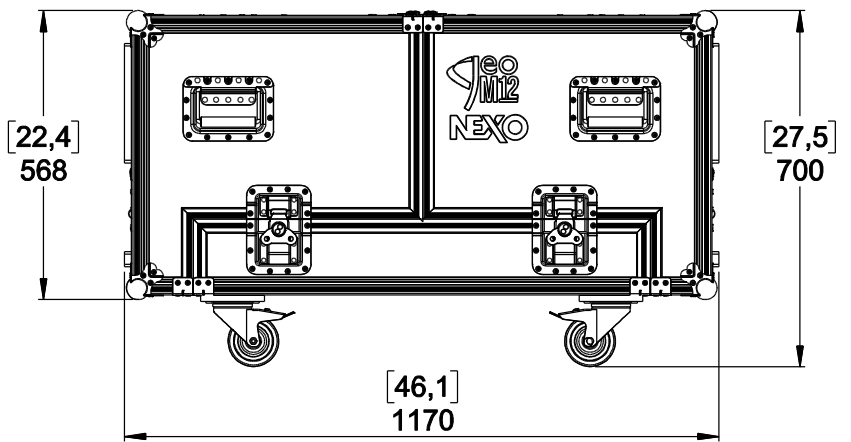
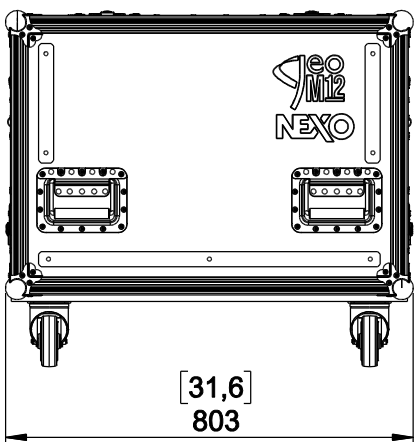

Weight: 56 kg / 123 lb

8.3.17 VNT-LSTKM1018

Parts

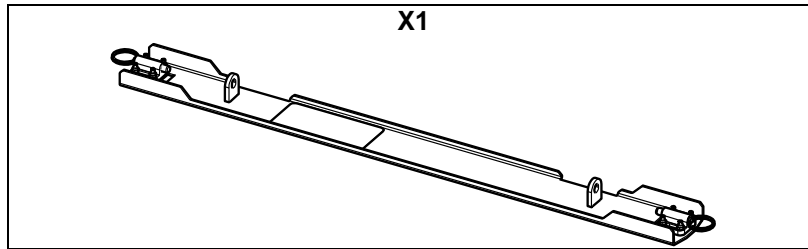



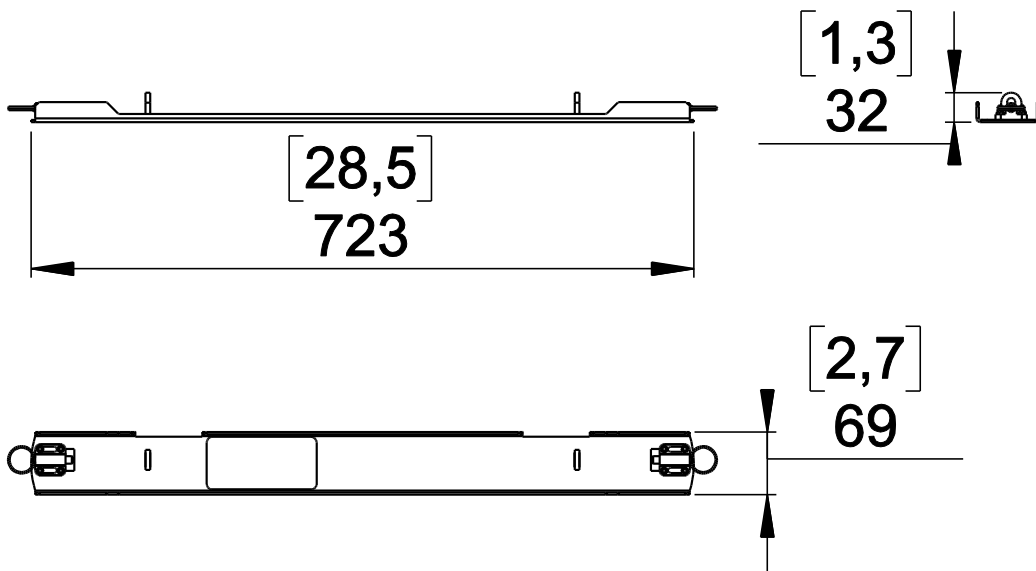

Dimensions



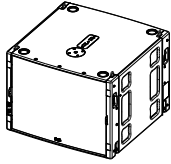
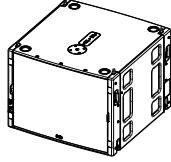
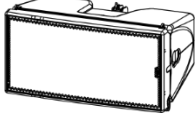
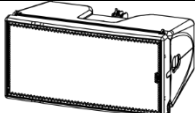
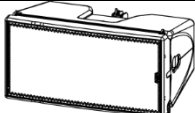
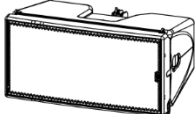

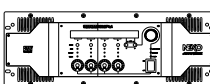
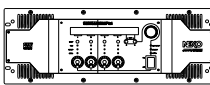
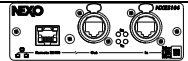
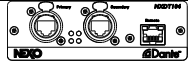
Weight: 1.5 kg / 3.3 lb

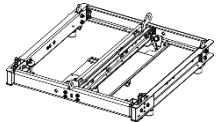
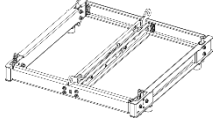
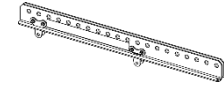
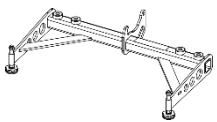
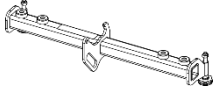
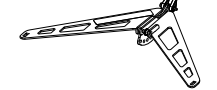
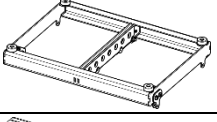
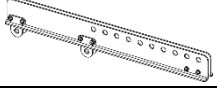
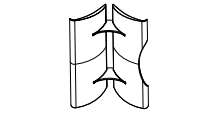
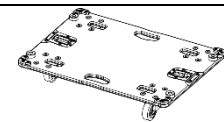
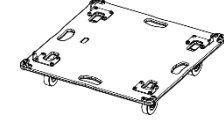
9 GEO M12 & MSUB18 MODULES & ACCESSORIES LIST

REFERENCE	DRAWING	DESCRIPTION
MSUB18		18" Subwoofer Touring Version
MSUB18-I		18" Subwoofer Installation Version
GEO M1210		12" - 10° Tangent Array Touring Version
GEO M1210-I		12" - 10° Tangent Array Installation Version
GEO M1220		12" - 20° Tangent Array Touring Version
GEO M1220-I		12" - 20° Tangent Array Installation Version
NXAMP4x1MK2		Powered Digital TD Controller 4x1300W
NXAMP4x2MK2		Powered Digital TD Controller 4x2500W
NXAMP4x4C		Powered Digital TD Controller 4x4000W / 220V
NXAMP4x4U		Powered Digital TD Controller 4x4000W / 110V
NX.ES104		Ethersound Network Card for NXAMP
NX.DT104MK2		Dante Network Card for NXAMP
NX.AE104		AES Card for NXAMP

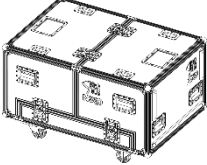
REFERENCE	DRAWING	DESCRIPTION
VNT-BUMPM12		Lifting / stacking bumper for GEO M12 and MSUB18
VNI-BUMPM12		Installation bumper for GEOM 12 and MSUB18
VNT-EXBARM12		Extension Bar for VNT-BUMPM12 and VNI-BUMPM12
VNT-GSTKM12L		Long Stacking Extension for VNT-BUMPM12
VNT-GSTKM12S		Short Stacking Extension for VNT-BUMPM12
VNT-MNSTKM12		Stacking Accessory for GEO M12 on top of MSUB18
GMT-LBUMPM12		Lifting / Stacking Bumper for GEO M12
GMT-EXBARM12L		Extension Bar for GMT-LBUMPM12
GMT-FLGM12		Pair of Magnetic Flanges for GEO M12120 & GEO M1220 120° horizontal dispersion
MST-WBMSUB18		Wheel board for MSUB18
MST-DOLLYMSUB18		Dolly for 2 x MSUB18
MST-COVMSUB18		Cover for 1 x MSUB18
MST-COV2MSUB18		Cover for 2 x MSUB18

GMT-2CASEM12		Flight Case for 2 x GEO M12
GMT-3CASEM12		Flight Case for 3 x GEO M12
VNT-LSTKM1018		Stacking Adapter MSUB18 – GEOM10 / MSUB15

10 USER NOTES

France

Nexo S.A.

Parc d'activité de la dame jeanne

F-60128 PLAILLY

Tel: +33 3 44 99 00 70

Fax: +33 3 44 99 00 30

E-mail: info@nexo.fr

nexo-sa.com