

Single Column Top Rigging

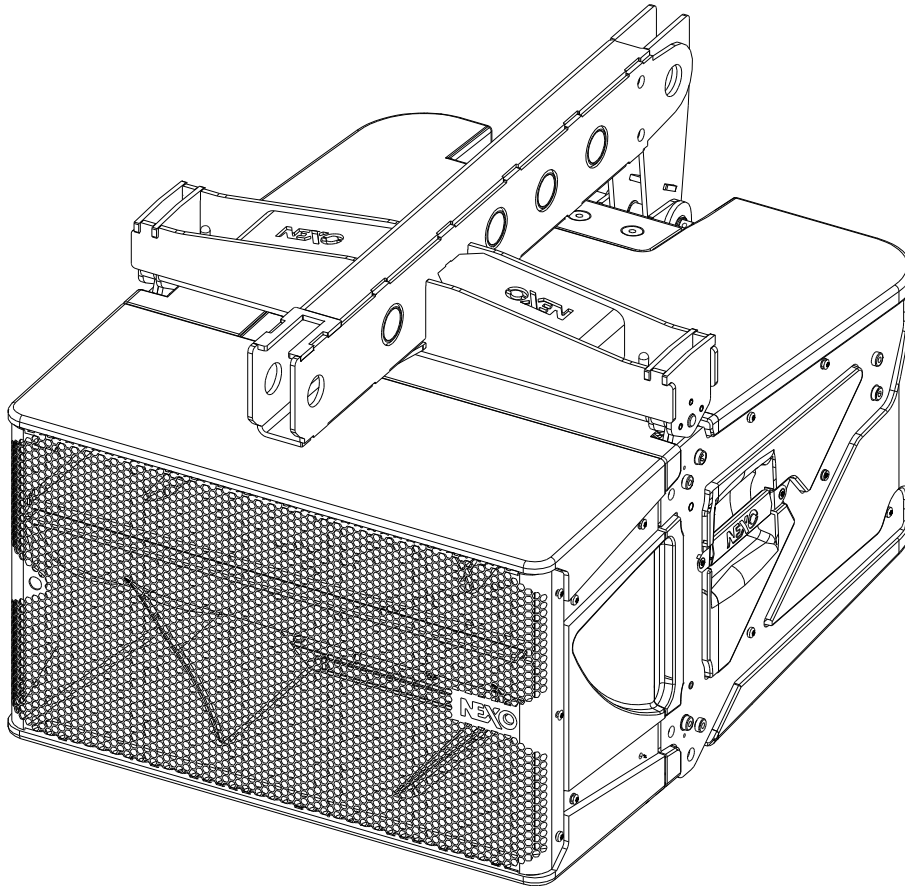

Contents:

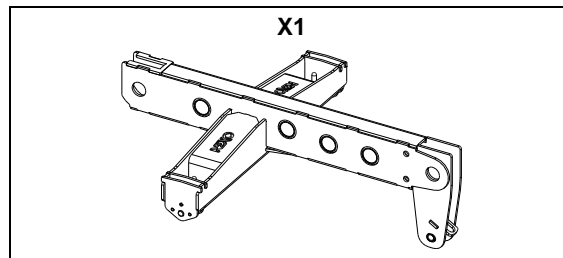

Weight: 16 kg / 35 lb

- Read this document before using.
- Keep this document.
- Observe all warnings and cautions.

Dimensions:

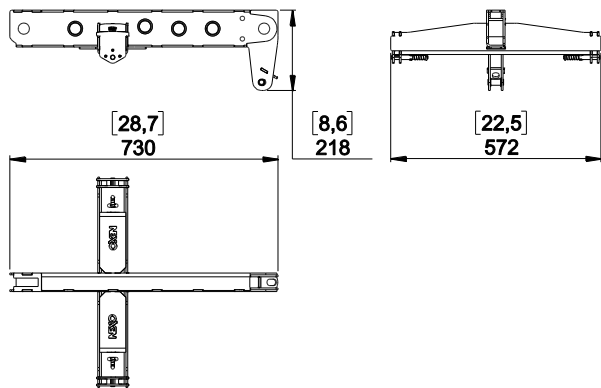

Use:

- Insert XBOW into the 3 fixing points: 2 on the sides and one at the back of the STM module
- Lock the lateral spring pins located inside the XBOW to the front lateral holes of the STM module.
- Insert the quick release pin at the back, in the hole located at the back of the STM module.

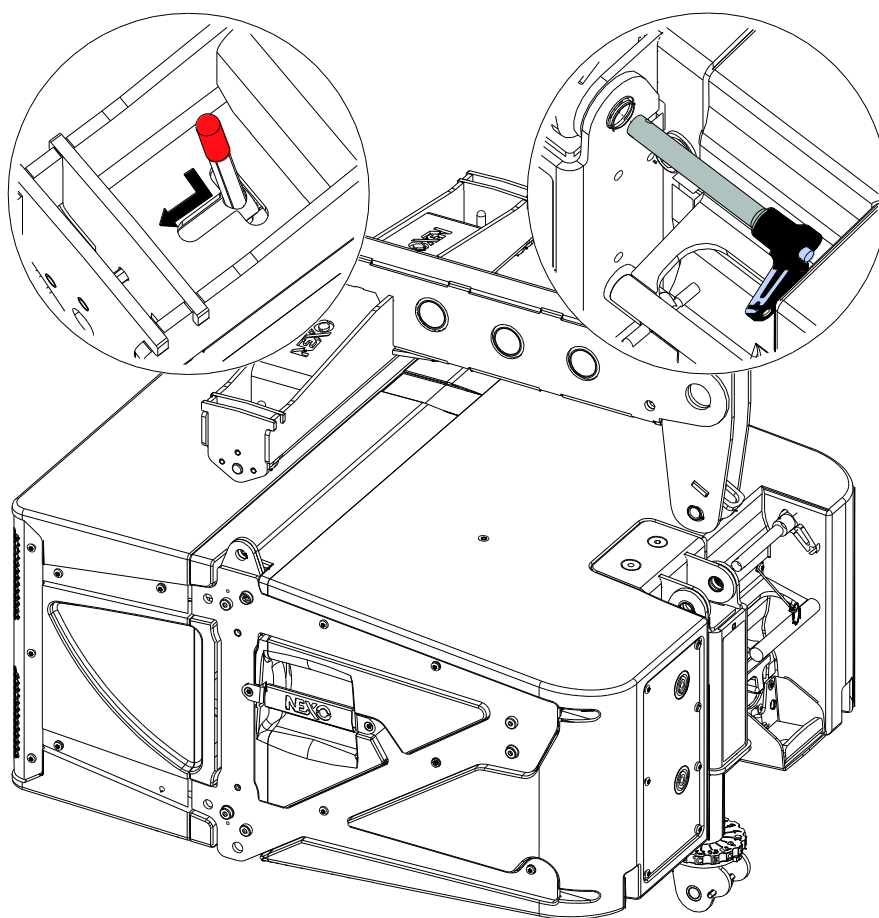

ENSURE XBOW LATERAL SPRING PINS AND REAR QUICK RELEASE PIN ARE PROPERLY LOCKED INTO TOP CABINET

- NEXO cannot accept responsibility for accidents caused by any factor other than defects in this product itself.
- Please check the web site nexo-sa.com for the latest update.

NEXO

nexo-sa.com
ZA du Pre de la Dame Jeanne
60128 PLAILLY - France

- Read this document before using.
- Keep this document.
- Observe all warnings and cautions.

